

AIRPLANE INFORMATION MANUAL

for the

ATPI AVIATOR T1 and XL SERIES

Aircraft with the ATPI Avionics System



At the time of issuance, this Information Manual is pre-release and is not current.

Therefore, this Information Manual is for reference only and cannot be used as a substitute for the official Pilot's Operating Handbook and FAA Approved Airplane Flight Manual.



Copyright © 2018 - All Rights Reserved
ATPI Incorporated
Jacksonville FL 32216

Section 1

General

Table of Contents

Introduction	3
The Airplane.....	7
Engine.....	7
Propeller.....	7
Fuel	8
Oil.....	8
Maximum Certificated Weights	8
Cabin and Entry Dimensions.....	8
Baggage Spaces and Entry Dimensions	8
Specific Loadings.....	8
Symbols, Abbreviations and Terminology	9
General Airspeed Terminology and Symbols	9
Meteorological Terminology	10
Engine Power Terminology	11
Performance and Flight Planning Terminology.....	11
Weight and Balance Terminology	12

Intentionally Left Blank

Introduction

This section contains information of general interest to pilots and owners. You will find the information useful in acquainting yourself with the airplane, as well as in loading, fueling, sheltering, and handling the airplane during ground operations. Additionally, this section contains definitions or explanations of symbols, abbreviations, and terminology used throughout this handbook.

• Note •

For specific information regarding the organization of this Handbook, revisions, supplements, and procedures to be used to obtain revision service for this handbook, See “Revising the Handbook” on page 3 of the “Foreword” section.

All liquid volumes referenced in this publication are expressed in United States Customary Units, e.g., U.S. Gallons.

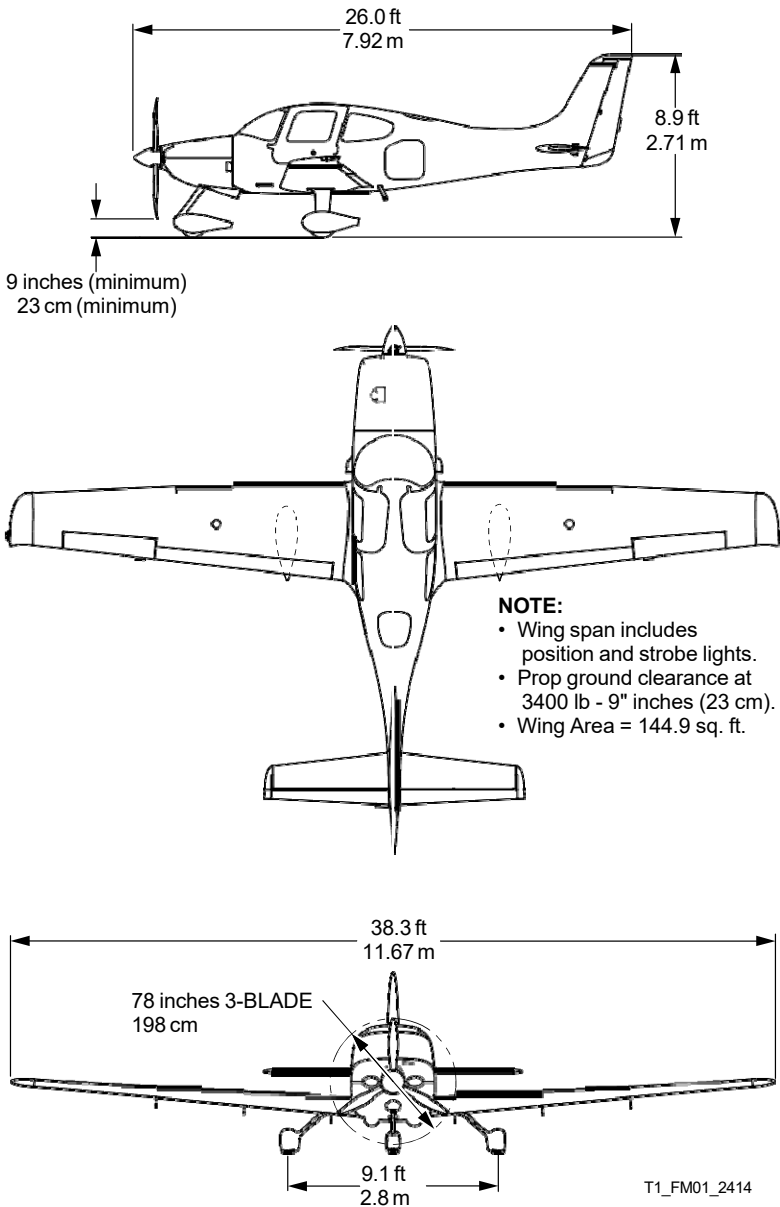
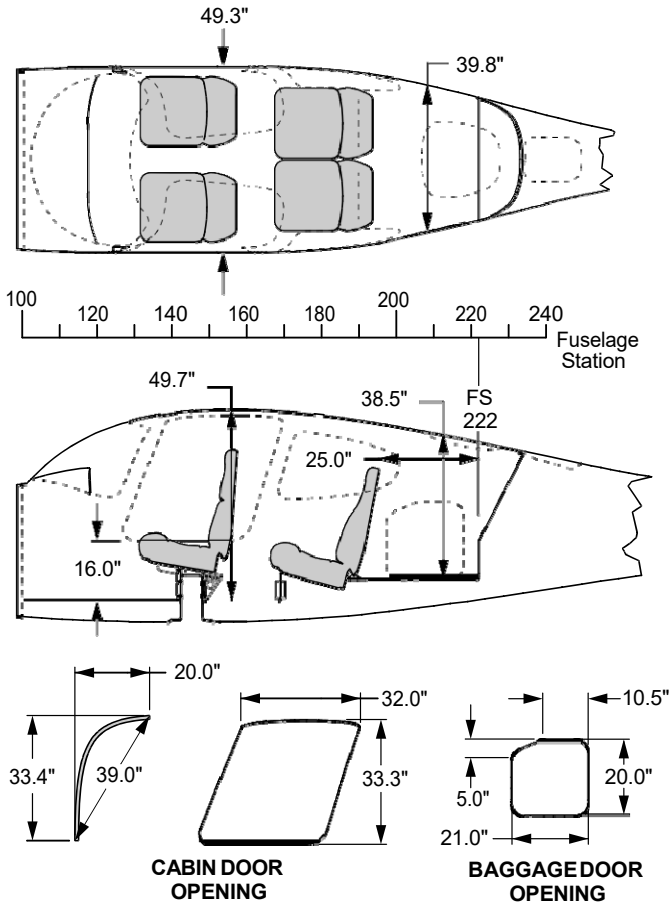

Figure 1-1
Airplane Three View



T1_FM06_1019

Location	Length	Width	Height	Volume
Cabin	122"	49.3"	49.7"	137 cu ft
Baggage Compartment	36"	39.8"	38.5"	32 cu ft

Figure 1-2
Airplane Interior Dimensions

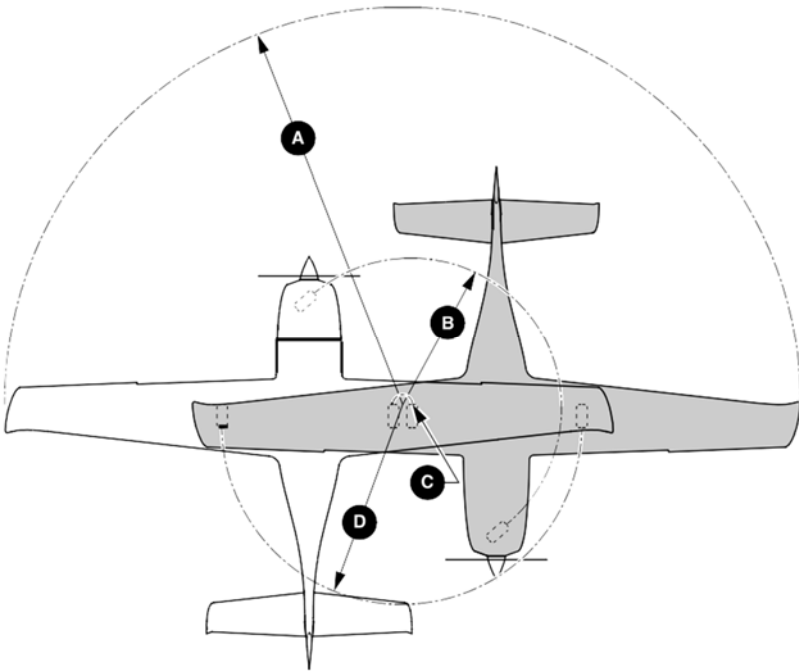

GROUND TURNING CLEARANCE

- A** RADIUS FOR WING TIP 24.3 ft. (7.41 m)
- B** RADIUS FOR NOSE GEAR 7.0 ft. (2.16 m)
- C** RADIUS FOR INSIDE GEAR 0.5 ft. (0.15 m)
- D** RADIUS FOR OUTSIDE GEAR 9.1 ft. (2.77 m)

TURNING RADII ARE CALCULATED USING ONE BRAKE AND PARTIAL POWER. ACTUAL TURNING RADIUS MAY VARY AS MUCH AS THREE FEET.

T1_FM01_2412

**Figure 1-3
Turning Radius**

The Airplane

Engine

Number of Engines	1
Number of Cylinders.....	6
Engine Manufacturer	Lycoming
Engine Model	O-360-A1A/TIO-540-J2B
Fuel Metering	Fuel Injected
Engine Cooling.....	Air Cooled
Engine Type.....	Horizontally Opposed, Direct Drive
Horsepower Rating.....	180 hp/350 hp @ 2700 rpm

Propeller

Hartzell

Propeller Type	Constant Speed, Three Blade
Model Number.....	PHC-J3YF-1RF/F7694(B)
Diameter.....	78.0" (76.0" Minimum)
Model Number.....	PHC-J3YF-1RF/F7693DF(B)
Diameter.....	78.0" (76.0" Minimum)

or

McCauley

Propeller Type	Constant Speed, Three Blade
Model Number.....	D3A34C443/78CYA-0
Diameter.....	78.0" (76.0" Minimum)

or

MT Propeller

Propeller Type	Constant Speed, Three Blade
Model Number.....	MTV-9-D/198-52
Diameter.....	78.0" (76.0" Minimum)

Fuel

Total Capacity94.5 U.S. Gallons (358.0 L)

Total Usable.....92.0 U.S. Gallons (348.0 L)

Approved Fuel Grades:

100 LL Grade Aviation Fuel (Blue)

100 (Formerly 100/130) Grade Aviation Fuel (Green)

Oil

Oil Capacity (Sump)8 U.S. Quarts (7.6 L)

Oil Grades:

All Temperatures SAE 15W-50, 20W-50, or 20W-60

Below 40°F (4°C).....SAE 30

Above 40°F (4°C).....SAE 50

Maximum Certificated Weights

Maximum Gross for Takeoff..... 3400 lb (1542 Kg)

Maximum Baggage Compartment Loading..... 130 lb (59 Kg)

Standard Empty Weight..... 2250 lb (1021 Kg)

Maximum Useful Load..... 1150 lb (522 Kg)

Full Fuel Payload..... 610 lb (277 Kg)

Cabin and Entry Dimensions

Refer to the preceding figures for dimensions of the cabin interior and entry door openings.

Baggage Spaces and Entry Dimensions

Dimensions of the baggage area and baggage door opening are illustrated in detail in Section 6.

Specific Loadings

Wing Loading..... 23.5 lb per square foot

Power Loading..... 11.0 lb per hp

Symbols, Abbreviations and Terminology

General Airspeed Terminology and Symbols

KCAS Knots Calibrated Airspeed is the indicated airspeed corrected for position and instrument error. Calibrated airspeed is equal to true airspeed in standard atmosphere at sea level.

KIAS Knots Indicated Airspeed is the speed shown on the airspeed indicator. The IAS values published in this handbook assume no instrument error.

KTAS Knots True Airspeed is the airspeed expressed in knots relative to undisturbed air which is KCAS corrected for altitude and temperature.

V_G Best Glide Speed is the speed at which the greatest flight distance is attained per unit of altitude lost with power off.

V_O Operating Maneuvering Speed is the maximum speed at which application of full control movement will not overstress the airplane.

V_{FE} Maximum Flap Extended Speed is the highest speed permissible with wing flaps in a prescribed extended position.

V_{NO} Maximum Structural Cruising Speed is the speed that should not be exceeded except in smooth air, and then only with caution.

V_{NE} Never Exceed Speed is the speed that may not be exceeded at any time.

V_{PD} Maximum Demonstrated Parachute Deployment Speed is the maximum speed at which parachute deployment has been demonstrated.

V_S Stalling Speed is minimum steady flight speed at which the aircraft is controllable.

V_S 50% Stalling Speed is minimum steady flight speed at which the aircraft is controllable with 50% flaps.

- V_{SO} Stalling Speed is the minimum steady flight speed at which the aircraft is controllable in the landing configuration (100% flaps) at the most unfavorable weight and balance.
- V_X Best Angle of Climb Speed is the speed at which the airplane will obtain the highest altitude in a given horizontal distance. The best angle-of-climb speed normally increases slightly with altitude.
- V_Y Best Rate of Climb Speed is the speed at which the airplane will obtain the maximum increase in altitude per unit of time. The best rate-of-climb speed decreases slightly with altitude.

Meteorological Terminology

- IMC** Instrument Meteorological Conditions are meteorological conditions expressed in terms of visibility, distance from cloud, and ceiling less than the minima for visual flight defined in FAR 91.155.
- ISA** International Standard Atmosphere (standard day) is an atmosphere where (1) the air is a dry perfect gas, (2) the temperature at sea level is 15°C, (3) the pressure at sea level is 29.92 in.Hg (1013.2 millibars), and (4) the temperature gradient from sea level to the altitude at which the temperature is -56.5°C is -0.00198°C per foot and zero above that altitude.
- MSL** Mean Sea Level is the average height of the surface of the sea for all stages of tide. In this Handbook, altitude given as MSL is the altitude above the mean sea level. It is the altitude read from the altimeter when the altimeter's barometric adjustment has been set to the altimeter setting obtained from ground meteorological sources.
- OAT** Outside Air Temperature is the free air static temperature obtained from inflight temperature indications or from ground meteorological sources. It is expressed in either degrees Celsius or degrees Fahrenheit.

- Pressure Altitude is the altitude read from the altimeter when the altimeter's barometric adjustment has been set to 29.92 in.Hg (1013 mb) corrected for position and instrument error. In this Handbook, altimeter instrument errors are assumed to be zero.
- Standard Temperature is the temperature that would be found at a given pressure altitude in the standard atmosphere. It is 15°C (59°F) at sea level pressure altitude and decreases approximately 2°C (3.6°F) for each 1000 feet of altitude increase. See ISA definition.

Engine Power Terminology

- HP Horsepower is the power developed by the engine.
- MCP Maximum Continuous Power is the maximum power that can be used continuously.
- MAP Manifold Pressure is the pressure measured in the engine's induction system expressed as in. Hg.
- RPM Revolutions Per Minute is engine rotational speed.
- Static RPM is RPM attained during a full-throttle engine runup when the airplane is on the ground and stationary.

Performance and Flight Planning Terminology

- g One "g" is a quantity of acceleration equal to that of earth's gravity.
- Demonstrated Crosswind Velocity is the velocity of the crosswind component for which adequate control of the airplane during taxi, takeoff, and landing was actually demonstrated during certification testing. Demonstrated crosswind is not considered to be limiting.
 - Service Ceiling is the maximum altitude at which the aircraft at maximum weight has the capability of climbing at a rate of 100 feet per minute.
- GPH Gallons Per Hour is the amount of fuel (in gallons) consumed by the aircraft per hour.

NMPG Nautical Miles Per Gallon is the distance (in nautical miles) which can be expected per gallon of fuel consumed at a specific engine power setting and/or flight configuration.

- Unusable Fuel is the quantity of fuel that cannot be safely used in flight.
- Usable Fuel is the fuel available for flight planning.

Weight and Balance Terminology

CG Center of Gravity is the point at which an airplane would balance if suspended. Its distance from the reference datum is found by dividing the total moment by the total weight of the airplane.

- Arm is the horizontal distance from the reference datum to the center of gravity (CG) of an item. The airplane's arm is obtained by adding the airplane's individual moments and dividing the sum by the total weight.
- Basic Empty Weight is the actual weight of the airplane including all operating equipment that has a fixed location in the airplane. The basic empty weight includes the weight of unusable fuel and full oil.

MAC Mean Aerodynamic Chord is the chord drawn through the centroid of the wing plan area.

LEMACH Leading Edge of Mean Aerodynamic Chord is the forward edge of MAC given in inches aft of the reference datum (fuselage station).

- Maximum Gross Weight is the maximum permissible weight of the airplane and its contents as listed in the aircraft specifications.
- Moment is the product of the weight of an item multiplied by its arm.
- Useful Load is the basic empty weight subtracted from the maximum weight of the aircraft. It is the maximum allowable combined weight of pilot, passengers, fuel and baggage.

- Station is a location along the airplane fuselage measured in inches from the reference datum and expressed as a number. For example: A point 123 inches aft of the reference datum is Fuselage Station 123.0 (FS 123).
- Reference Datum is an imaginary vertical plane from which all horizontal distances are measured for balance purposes.
- Tare is the weight of all items used to hold or position the airplane on the scales for weighing. Tare includes blocks, shims, and chocks. Tare weight must be subtracted from the associated scale reading.

Intentionally Left Blank

Section 2

Limitations

Table of Contents

Introduction	3
Certification Status	3
Airspeed Limitations	4
Airspeed Indicator Markings	5
Powerplant Limitations	6
Engine	6
Propeller	7
Weight Limits	7
Engine Instrument Markings & Annunciations	8
Power Plant	8
Fuel	9
Electrical	9
Center of Gravity Limits	10
Maneuver Limits	11
Flight Load Factor Limits	11
Minimum Flight Crew	11
Kinds of Operation	12
Kinds of Operation Equipment List	12
Icing	16
Runway Surface	16
Taxi Power	16
Fuel Limits	17
Altitude Limits	17
Environmental Conditions	17
Maximum Occupancy	17
Systems and Equipment Limits	18
ATPI Integrated Avionics System	18
L-3 Skywatch Traffic Advisory System	21
L-3 Stormscope Weather Information System	21
Max Viz Enhanced Vision System (Optional)	21
Air Conditioning System (Optional)	21
Inflatable Restraint System	22
Flap Limitations	22
Paint	22
ATPI Airframe Parachute System (APS)	22
Other Limitations	22

Smoking 22
Placards..... 23

Intentionally Left Blank

Introduction

The limitations included in this Section of the Pilot's Operating Handbook (POH) are approved by the Federal Aviation Administration.

This section provides operating limitations, instrument markings and basic placards required by regulation and necessary for the safe operation of the aircraft and its standard systems and equipment. Refer to Section 9 of this handbook for amended operating limitations for airplanes equipped with optional equipment. Compliance with the operating limitations in this section and in Section 9 is required by Federal Aviation Regulations.

• Note •

Limitations associated with optional equipment are not described in this section. For optional equipment limitations, refer to Section 9, Supplements

Certification Status

The aircraft is certificated under the requirements of Federal Aviation Regulations (FAR) Part 23 as documented by FAA Type Certificate TC PENDING.

Airspeed Limitations

The indicated airspeeds in the following table are based upon Section 5 Airspeed Calibrations using the normal static source. When using the alternate static source, allow for the airspeed calibration variations between the normal and alternate static sources.

Speed	KIAS	KCAS	Remarks
V _{NE}	230	234	Never Exceed Speed is the speed limit that may not be exceeded at any time.
V _{NO}	187	190	Maximum Structural Cruising Speed is the speed that should not be exceeded except in smooth air, and then only with caution.
V _O 3400 Lb	143	145	Operating Maneuvering Speed is the maximum speed at which full control travel may be used. Below this speed the airplane stalls before limit loads are reached. Above this speed, full control movements can damage the airplane.
V _{FE} 50% Flaps 100% Flaps	149 114	150 114	Maximum Flap Extended Speed is the highest speed permissible with wing flaps extended.
V _{PD}	133	135	Maximum Demonstrated Parachute Deployment Speed is the maximum speed at which parachute deployment has been demonstrated.

Airspeed Indicator Markings

The airspeed indicator markings are based upon Section 5 Airspeed Calibrations using the normal static source. When using the alternate static source, allow for the airspeed calibration variations between the normal and alternate static sources.

Marking	Value (KIAS)	Remarks
White Arc	62 - 104	Full Flap Operating Range. Lower limit is the most adverse stall speed in the landing configuration. Upper limit is the maximum speed permissible with flaps extended.
Green Arc	73 - 177	Normal Operating Range. Lower limit is the maximum weight stall at most forward CG with flaps retracted. Upper limit is the maximum structural cruising speed.
Yellow Arc	177 - 234	Caution Range. Operations must be conducted with caution and only in smooth air.
Red Line	234	Never exceed speed. Maximum speed for all operations.

Powerplant Limitations

Engine

Lycoming..... O-360-A1A/TIO-540-J2B

Power Rating 180 hp/350 hp @ 2700 RPM

Maximum RPM..... 2700 RPM

Oil Temperature..... 240°F (115°C) maximum

Oil Pressure:

Minimum..... 10 psi

Maximum..... 100 psi

Approved Oils:

Engine Break-In: For first 25 hours of operation or until oil consumption stabilizes use straight mineral oil conforming to MIL-L-6082. If engine oil must be added to the factory installed oil, add only MIL-L-6082 straight mineral oil.

After Engine Break-In: Use only oils conforming to Lycoming (Ashless Dispersant Lubrication Oil) or MHS-25 (Synthetic Lubrication Oil). Refer to Section 8, Approved Oils.

All Temperatures 15W-50, 20W-50 or 20W-60

Above 40°F (4°C)..... SAE 50, 20W50, or 20W60

Below 40°F (4°C)..... SAE 30, 10W30, 15W50, or 20W50

Fuel Grade..... Aviation Grade 100 LL (Blue) or 100 (green)

• Note •

Refer to Fuel Limits in this section for operational limitations regarding fuel and fuel storage.

Propeller***Hartzell***

Propeller TypeConstant Speed, Three Blade
 Model Number..... PHC-J3YF-1RF/F7694(B)
 Diameter.....78.0" (76.0" Minimum)
 Model Number..... PHC-J3YF-1RF/F7693DF(B)
 Diameter.....78.0" (76.0" Minimum)

or

McCauley

Propeller TypeConstant Speed, Three Blade
 Model Number.....D3A34C443/78CYA-0
 Diameter.....78.0" (76.0" Minimum)

or

MT Propeller

Propeller TypeConstant Speed, Three Blade
 Model Number.....MTV-9-D/198-52
 Diameter.....78.0" (76.0" Minimum)

Weight Limits

Maximum Takeoff Weight 3400 lb (1542 Kg)
 Maximum Weight in Baggage Compartment..... 130 lb (59 Kg)

Engine Instrument Markings & Annunciations

The following describes the engine instrument markings. Associated Warning and Caution Annunciations are shown in capitalized text.

Power Plant

Instrument (Range & Units)	Red Arc/Bar	Yellow Arc/Bar	Green Arc/ Bar	Yellow Arc/ Bar	Red Arc/Bar
	Lower Warning Range	Minimum Caution Range	Normal Range	Maximum Caution Range	Upper Warning Range
Cylinder Head Temperature (100°F – 500°F)	—	—	240 – 420	420 – 460 CHT	> 460 CHT
Engine Speed (0 – 3000 RPM)	—	—	500 – 2700	—	> 2700* RPM
Exhaust Gas Temperature (1000°F – 1600°F)	—	—	500 – 1750	—	—
Manifold Pressure (10 – 35 Inch Hg)	—	—	15 – 29.5	—	—
Oil Pressure (0 – 100 PSI)	0 – 10** OIL PRESS	10 – 30** OIL PRESS	30 – 60	60 – 100	> 100** OIL PRESS
Oil Temperature (75°F – 250°F)	—	75 – 100	100 – 240	—	> 240 OIL TEMP
Percent Power (0 – 100%)	—	—	0 – 100	—	—

*Engine Speed Warning when RPM between 2710 and 2730 for more than 10 seconds OR when RPM greater than 2730 for more than 5 seconds.

**Oil Pressure Caution when oil pressure is between 10 and 29 psi and RPM is greater than 1000. Oil Pressure Warning when oil pressure is below 10 psi, OR oil pressure is above 100 psi.

Fuel

Instrument (Range & Units)	Red Arc/Bar	Yellow Arc/Bar	Green Arc/Bar	Yellow Arc/Bar	Red Arc/Bar
	Minimum	Minimum Caution Range	Normal Range	Maximum Caution Range	Maximum
Fuel Flow*** (0 – 30 U.S. Gal/Hr)	—	—	0 – 30	—	—
Fuel Totalizer (U.S. Gallon)	N < 9 FUEL QTY	9 – 18	> 18	—	—
Fuel Quantity Gage (0 – 46 U.S. Gallon)	0	10 – 14	—	—	—

Electrical

Instrument (Range & Units)	Red Arc/Bar	Yellow Arc/Bar	Green Arc/Bar	Yellow Arc/Bar	Red Arc/Bar
	Minimum	Minimum Caution Range	Normal Range	Maximum Caution Range	Maximum
Essential Bus Volts (0 – 36 Volts)	0 – 24.4 ESS BUS	—	24.5 – 32	—	> 32 ESS BUS
Main Bus 1 Voltage (0 – 36 Volts)	—	0 – 24.4 M BUS 1	24.5 – 32	—	> 32 M BUS 1
Main Bus 2 Voltage (0 – 36 Volts)	—	0 – 24.4 M BUS 2	24.5 – 32	—	> 32 M BUS 2
Alternator 1 Current (0 – 100 Amps)	—	—	2 – 100	0 – 1* ALT 1	—
Alternator 2 Current (0 – 70 Amps)	—	—	2 – 100	0 – 1* ALT 2	—
Battery 1 Current (-59 to 59 Amps)	—	—	-4 – 59	-59 to -5** BATT 1	—

*20 seconds delay.

**30 second delay.

***Serials w/ Integrated System software load 0764-02 and later: Dynamically changes based on engine parameters.

Center of Gravity Limits

Reference Datum100 inches forward of firewall

Forward.....Refer to Figure 2-1

Aft.....Refer to Figure 2-1

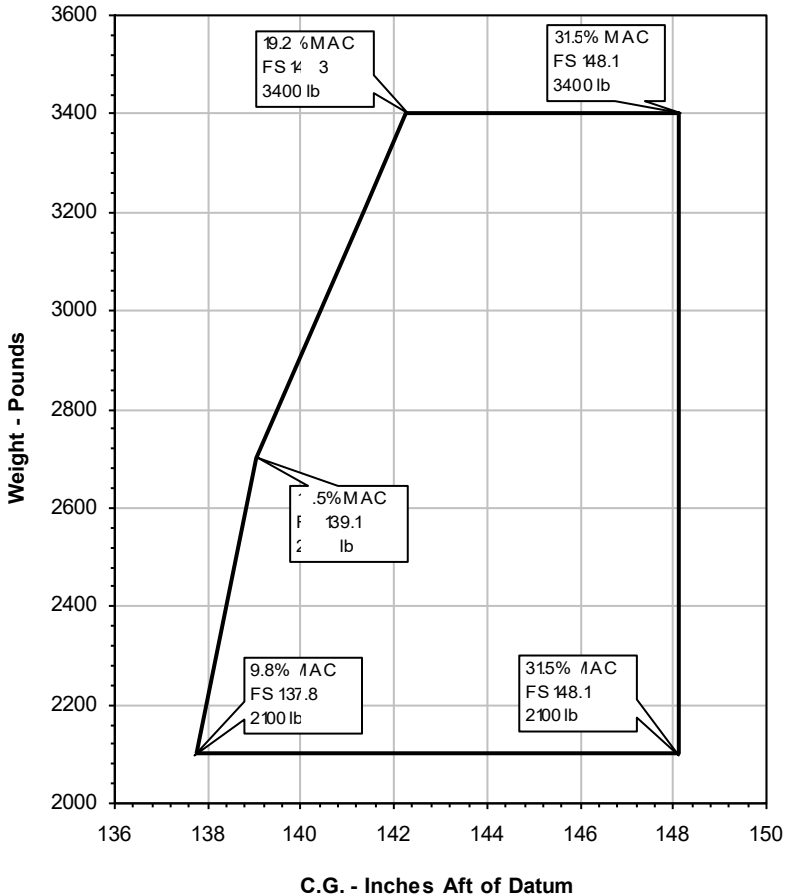

FORWARD LIMIT - The forward limit is FS 137.8 (9.8% MAC) at 2100 lb, with straight line taper to FS 139.1 (12.5% MAC) at 2700 lb, to FS 142.3 (19.2% MAC) at 3400 lb.
AFT LIMIT - The aft limit is FS 148.1 (31.5% MAC) at all weights from 2100 lb to 3400 lb.

Figure 2-1
CG Envelope

Maneuver Limits

Aerobatic maneuvers are prohibited.

Spins are prohibited.

This airplane is certified in the normal category and is not designed for aerobatic operations. Only those operations incidental to normal flight are approved. These operations include normal stalls, chandelles, lazy eights, and turns in which the angle of bank is limited to 60°.

• Note •

Because the aircraft has not been certified for spin recovery, the ATPI Airframe Parachute System (APS) must be deployed if the airplane departs controlled flight. Refer to Section 3 – Emergency Procedures, Spins.

Flight Load Factor Limits

Flaps UP (0%), 3400 lb.+3.8g, -1.9g

Flaps 50%+1.9g, -0g

Flaps 100%, 3400 lb.....+1.9g, -0g

Minimum Flight Crew

The minimum flight crew is one pilot.

Kinds of Operation

The aircraft is equipped and approved for the following type operations:

- VFR day and night.
- IFR day and night.

Kinds of Operation Equipment List

The following listing summarizes the equipment required under Federal Aviation Regulations (FAR) Part 23 for airworthiness under the listed kind of operation. Those minimum items of equipment necessary under the operating rules are defined in FAR Part 91 and FAR Part 135 as applicable.

• Note •

All references to types of flight operations on the operating limitations placards are based upon equipment installed at the time of Airworthiness Certificate issuance.

System, Instrument, and/or Equipment	Kinds of Operation				Remarks, Notes, and/or Exceptions
	VFR Day	VFR Nt.	IFR Day	IFR Nt.	
Placards and Markings					
Airplane Flight Manual	1	1	1	1	Included w/ POH.
Communications					
VHF COM	—	—	1	1	
Electrical Power					
Battery 1	1	1	1	1	
Battery 2	—	—	1	1	
Alternator 1	1	1	1	1	
Alternator 2	—	—	1	1	
Amp Meter/Indication	1	1	1	1	
Low Volts Annunciator	1	1	1	1	

System, Instrument, and/ or Equipment	Kinds of Operation (Continued)				Remarks, Notes, and/or Exceptions
	VFR Day	VFR Nt.	IFR Day	IFR Nt.	
ALT 1 Annunciator	1	1	1	1	
ALT 2 Annunciator	—	—	1	1	
Circuit Breakers	A/R	A/R	A/R	A/R	As required.
Equipment & Furnishings					
Emergency Locator Transmitter	1	1	1	1	
Restraint System	A/R	A/R	A/R	A/R	One seat belt for each occupant.
Fire Protection					
Fire Extinguisher	1	1	1	1	
Flight Controls					
Flap Position Indicator	1	1	1	1	
Flap System	1	1	1	1	
Pitch Trim Indicator	1	1	1	1	
Pitch Trim System	1	1	1	1	
Roll Trim Indicator	1	1	1	1	
Roll Trim System	1	1	1	1	
Stall Warning System	1	1	1	1	
Fuel					
Auxiliary Fuel Pump	1	1	1	1	
Fuel Quantity Indicator	2	2	2	2	
Fuel Selector Valve	1	1	1	1	

System, Instrument, and/ or Equipment	Kinds of Operation (Continued)				Remarks, Notes, and/or Exceptions
	VFR Day	VFR Nt.	IFR Day	IFR Nt.	
Ice & Rain Protection					
Alternate Engine Air Induc- tion System	1	1	1	1	
Alternate Static Air Source	1	1	1	1	
Pitot Heater	—	—	1	1	
Landing Gear					
Wheel Pants	—	—	—	—	May be removed.
Lights					
PFD Bezel Lighting	—	—	—	1	
PFD Backlighting	*	1	1	1	*Required if MFD Backlighting Fails. Engine Indicators Must Be Shown in Backup Mode.
MFD Bezel Lighting	—	—	—	1	
MFD Backlighting	*	1	1	1	*Required if PFD Backlighting Fails. Engine Indicators Must Be Shown in Backup Mode.
Anticollision Lights	2	2	2	2	
Instrument Lights	—	1	—	1	
Navigation Lights	—	2	—	2	
Landing Light	—	1	—	1	For hire opera- tions.
Flash Light	—	1	—	1	

System, Instrument, and/ or Equipment	Kinds of Operation (Continued)				Remarks, Notes, and/or Exceptions
	VFR Day	VFR Nt.	IFR Day	IFR Nt.	
Navigation & Pitot Static					
Airspeed Indicator	1	1	1	1	
Altimeter	1	1	1	1	
Magnetic Compass	1	1	1	1	
Pitot System	1	1	1	1	
Static System, Normal	1	1	1	1	
Attitude Indicator	—	—	1	1	
Clock	—	—	1	1	
Gyroscopic Directional Indi- cation (HSI)	—	—	1	1	
Magnetometer	—	—	1	1	
Nav Radio	—	—	1	1	
PFD Airspeed Indication	—	—	1	1	
PFD Altitude Indication	—	—	1	1	
PFD Attitude Indication	—	—	1	1	
PFD Heading Indication	—	—	1	1	
PFD Slip/Skid Indication	—	—	1	1	
Turn Coordinator	—	—	1	1	
Altitude Encoder	A/R	A/R	1	1	As required per procedure.
GPS Receiver/Navigator	—	—	A/R	A/R	As required per procedure.
Marker Beacon Receiver	—	—	A/R	A/R	As required per procedure.
VHF Navigation Radio	—	—	A/R	A/R	As required per procedure.

System, Instrument, and/ or Equipment	Kinds of Operation (Continued)				Remarks, Notes, and/or Exceptions
	VFR Day	VFR Nt.	IFR Day	IFR Nt.	
Vertical Speed Indicator	—	—	—	—	
Engine Indicating					
Cylinder Head Temperature Indication	—	—	—	—	
Exhaust Gas Temperature Indication	—	—	—	—	
Fuel Flow Indication	1	1	1	1	
Manifold Pressure Indica- tion	1	1	1	1	
Oil Pressure Indication	1	1	1	1	
Oil Quantity Indicator (Dip- stick)	1	1	1	1	
Oil Temperature Indication	1	1	1	1	
Engine Speed	1	1	1	1	
Special Equipment					
ATPI Airframe Parachute (APS)	1	1	1	1	

Icing

Flight into known icing conditions is prohibited.

Runway Surface

This airplane may be operated on any smooth runway surface.

Taxi Power

Maximum continuous engine speed for taxiing is 1000 RPM on flat, smooth, hard surfaces. Power settings slightly above 1000 RPM are permissible to start motion, for turf, soft surfaces, and on inclines. Use minimum power to maintain taxi speed.

Fuel Limits

Approved Fuel Aviation Grade 100 LL (Blue) or 100 (Green)

Total Fuel Capacity 94.5 U.S. Gallon (358.0 L)

Total Fuel Each Tank 47.25 U.S. Gallon (179.0 L)

Total Usable Fuel (all flight conditions) 92.0 U.S. Gallon (348.0 L)

Maximum Allowable Fuel Imbalance 10.0 U.S. Gallon (¼ tank)

The fuel pump must be set to BOOST for takeoff, climb, landing, and for switching fuel tanks.

Altitude Limits

Maximum Takeoff Altitude 10,000 Feet MSL

Maximum Operating Altitude 17,500 Feet MSL

The operating rules (FAR Part 91 and FAR Part 135) require the use of supplemental oxygen at specified altitudes below the maximum operating altitude.

Environmental Conditions

For operation of the airplane below an outside air temperature of -10°F (-23°C), use of cowl inlet covers approved by ATPI Inc. and listed in the Winterization Kit AFM Supplement P/N ATPI-T1-WKAFM is required.

Maximum Occupancy

Occupancy of this airplane is limited to four persons (the pilot and three passengers).

Systems and Equipment Limits

ATPI Integrated Avionics System

1. The appropriate revision of the ATPI Integrated Cockpit Reference Guide (p/n ATPI-T1-ICRG-XX, where X can be any digit from 0 to 19) must be immediately available to the pilot during flight. The system software version stated in the reference guide must be appropriate for the system software version displayed on the equipment.
2. The Avionics System integrates with separately approved sensor installations. Adherence to limitations in appropriate installation POH supplements is mandatory.
3. IFR enroute and terminal navigation is prohibited unless the pilot verifies the currency of the database or verifies each selected waypoint for accuracy by reference to current approved data.
4. Instrument approach navigation predicated upon the GPS Receiver must be accomplished in accordance with approved instrument approach procedures that are retrieved from the GPS equipment database. The GPS equipment database must incorporate the current update cycle.
 - a. Receiver Autonomous Integrity Monitoring (RAIM) must be available at the Final Approach Fix for instrument approach procedures that do not use the integrity information from Satellite Based Augmentation Systems (SBAS). For flight planning purposes, in areas where SBAS coverage is not available, the pilot must check RAIM availability.
 - b. Accomplishment of ILS, LOC, LOC-BC, LDA, SDF, MLS or any other type of approach not approved for GPS overlay with the GPS receiver is not authorized.
 - c. Use of the VOR/ILS receiver to fly approaches not approved for GPS require VOR/ILS navigation data to be present on the display.
 - d. Vertical Navigation information for approach procedures that do not meet the ICAO Annex 10 requirements for precision approaches may be utilized for advisory information only. Use of Vertical Navigation information for Instrument Approach Procedures does not guarantee step-down fix altitude protection, or arrival at approach minimums in normal position to land.

- e. IFR non-precision approach approval is limited to published approaches within the U.S. National Airspace System. Approaches to airports in other airspace are not approved unless authorized by the appropriate governing authority.
- f. RNAV approaches must be conducted utilizing the GPS sensor.
- g. Except when GFC 700 with system software 0764.09 or later installed, when conducting missed approach procedures, autopilot (if installed) coupled operation is prohibited until the pilot has established a rate of climb that ensures all altitude requirements of the procedure will be met.
- h. The Integrated Avionics System is compliant with AC 90-100A. As such, the ATPI Integrated system is eligible to fly RNAV 'Q' or 'T' routes, RNAV SID/STAR/ODPs and eligible to use RNAV substitution or RNAV alternate means of navigation (US Only). Refer to AC 90-100A for additional operator requirements and limitations.
- i. The Integrated Avionics System includes dual, independent navigation sensors that meet the standards set forth in TSO-C145a/ETSO-C145 (Sensors) and TSO-C146a/ ETSO-C146 (Display Units) for Class 3 systems.
- j. The Integrated Avionics System has been installed in accordance with AC 20-138A and is approved for navigation using GPS and SBAS (within the coverage of a Satellite Based Augmentation System complying with ICAO annex 10) for IFR enroute, terminal and approach operations.
- k. The Integrated Avionics System complies with the standards set forth in AC 90-96A and JAA TGL-10 (rev 1) for BRNAV and PRNAV operations.
- l. The navigation databases employed by the Integrated Avionics System meet the requirements set forth in AC 20-153 for database integrity, quality and database management practices. The data in the navigation databases are referenced to the WGS-84 reference system.
- m. The Integrated Avionics System complies with the standards set forth in AMC 20-27 and NPA 2009-04 (AMC 20-28) for RNAV operations including LNAV/VNAV and LPV approach operations.

5. Navigation using the Integrated Avionics System is not authorized in the following geographic areas:
 - a. north of 70°North latitude (northern polar region),
 - b. south of 70°South latitude (southern polar region),
 - c. north of the 65°North latitude between longitude 75°W and 120°W (Northern Canada),
 - d. south of 55°south latitude between longitude 120°E and 165°E (region south of Australia and New Zealand).
6. The MFD checklist display supplements the Pilot Operating Handbook checklists and is advisory only. Use of the MFD checklists as the primary set of on-board airplane checklists is prohibited.
7. The NAVIGATION MAP is intended only to enhance situational awareness. Use of the NAVIGATION MAP page for pilotage navigation is prohibited.
8. The TERRAIN PROXIMITY MAP is intended only to enhance situational awareness. Use of the TERRAIN PROXIMITY information for primary terrain avoidance is prohibited.
9. LTNG information on the NAVIGATION MAP or WEATHER MAP is approved only as an aid to hazardous weather avoidance. Use of the WEATHER MAP for hazardous weather penetration is prohibited.
10. The SYNTHETIC VISION SYSTEM (SVS) cannot be used for flight guidance, navigation, traffic avoidance, or terrain avoidance. Maneuvering the airplane in any phase of flight such as taxi, takeoff, approach, landing, or roll out shall not be predicated on SVS imagery. The synthetic vision system is not intended to be used independently of traditional attitude instrumentation. Consequently, SVS is disabled when traditional attitude instrumentation is not available. Otherwise, the traditional attitude instrumentation will always be visible in the foreground with SVS features in the background.
11. Use of the TRAFFIC ADVISORY SYSTEM (TAS) to maneuver the airplane to avoid traffic is prohibited. The TAS is intended for advisory use only. TAS is intended only to help the pilot to visually located traffic. It is the responsibility of the pilot to see and maneuver to avoid traffic.

12. Use of use of portable electronic devices during takeoff and landing is prohibited.

L-3 Skywatch Traffic Advisory System (Optional)

1. Traffic information shown on the Integrated Avionics System displays is provided as an aid in visually acquiring traffic. Pilots must maneuver the aircraft based only upon ATC guidance or positive visual acquisition of conflicting traffic.
2. If the pilot is advised by ATC to disable transponder altitude reporting, Traffic Advisory System must be turned OFF.
3. When option installed, the appropriate revision of the L-3 Avionics Systems SkyWatch Traffic Advisory System Model SKY497 Pilot's Guide (p/n 009-10801-001) must be available to the pilot during flight.

L-3 Stormscope Weather Information System (Optional)

1. Use of the Stormscope is not intended for hazardous weather penetration (thunderstorm penetration). Stormscope information, as displayed on the Integrated Avionics System, is to be used only for weather avoidance, not penetration.
2. When option installed, the appropriate revision of the L-3 Avionics Systems WX500 Stormscope Series II Weather Mapping Sensor User's Guide, (p/n 009-11501-001) must be available to the pilot during flight.

Max Viz Enhanced Vision System (Optional)

1. The Enhanced Vision System (EVS) cannot be used for flight guidance, navigation, traffic avoidance, or terrain avoidance. Maneuvering the airplane in any phase of flight such as taxi, takeoff, approach, landing, or roll out shall not be predicated on EVS imagery. The EVS shall only be used as an aide to assist the flight crew to visually acquire objects normally viewed through the cockpit windows.
2. The Max Viz Enhanced Vision System Information Manual, P/N 309100024 Revision 01 or later must be available to the pilot during flight.

Air Conditioning System (Optional)

The use of Recirculation Mode during flight is prohibited.

Inflatable Restraint System (Optional)

Use of a child safety seat with the inflatable restraint system is prohibited.

Flap Limitations

Approved Takeoff Settings UP (0%) or 50%

Approved Landing Settings 0%, 50%, or 100%

Paint

To ensure that the temperature of the composite structure does not exceed 150°F (66°C), the outer surface of the airplane must be painted in accordance with the paint colors and schemes as specified in the Airplane Maintenance Manual. Refer to Airplane Maintenance Manual (AMM), Chapter 51, for specific paint requirements.

ATPI Airframe Parachute System (APS)

VPD Maximum Demonstrated Deployment Speed 133 KIAS

• Note •

Refer to Section 10 – Safety Information, for additional APS guidance.

Other Limitations

Smoking

Smoking is prohibited in this airplane.

Placards

Engine compartment, inside oil filler access:

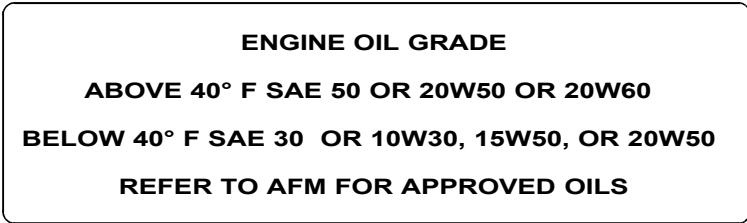

Wing, adjacent to fuel filler APS:



Upper fuselage, either side of APS rocket cover:



T1_FM02_2680

Figure 2-2
Placards (Sheet 1 of 6)

Elevator and Rudder, both sides:



Left fuselage, on external power supply door:

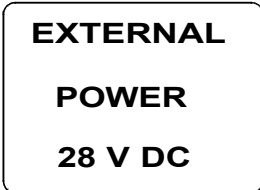

Doors, above and below latch:

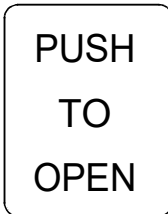

Wing, adjacent to fluid filler cap:

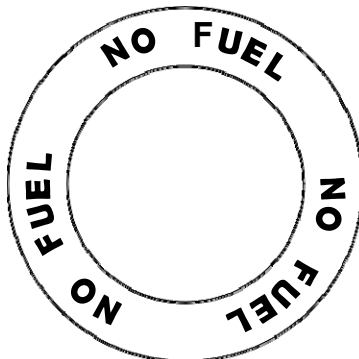
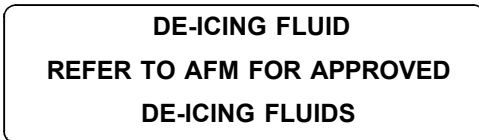

Serials w/ Ice Protection.

T1_FM02_2681

**Figure 2-3
Placards (Sheet 2 of 6)**

Engine control panel:

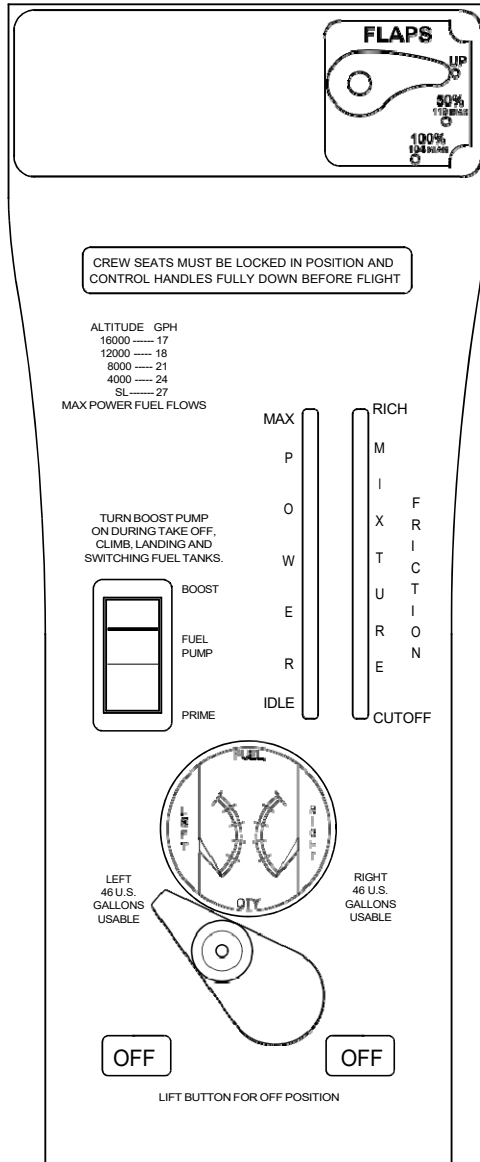

T1_FM02_2682

Figure 2-4
(Sheet 3 of 6)

Wing, flap aft edge and fuselage vortex generator:

NO STEP

Cabin Door Window, lower edge, centered, applied upside down:

RESCUE: FRACTURE AND REMOVE WINDOW

Bolster Switch Panel, left edge:

**THIS AIRCRAFT IS CERTIFIED FOR THE
FOLLOWING FLIGHT OPERATIONS:
DAY - NIGHT - VFR - IFR
(WITH REQUIRED EQUIPMENT)
FLIGHT INTO KNOWN ICING IS PROHIBITED
OPERATE PER AIRPLANE FLIGHT MANUAL**

Instrument Panel, left :

**MANEUVERING
SPEED: V_o 133 KIAS
NORMAL CATEGORY AIRPLANE
NO ACROBATIC MANEUVERS,
INCLUDING SPINS, APPROVED**

T1_FM02_5

**Figure 2-5
(Sheet 4 of 6)**

Instrument Panel, center:



Bolster Panel, both sides:



Baggage Compartment, aft edge:

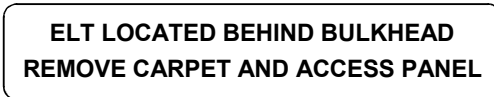

Instrument Panel:



Cabin Window, above door latch:

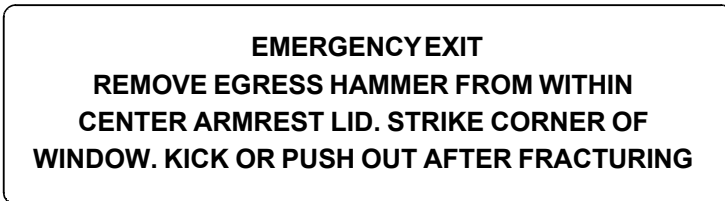

Baggage Compartment Door, inside:

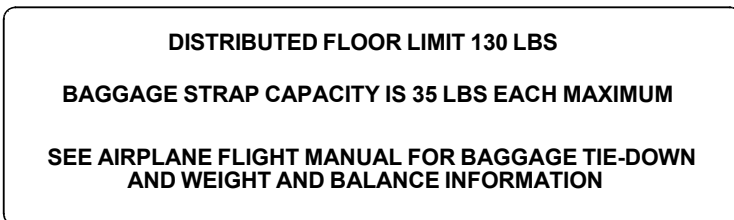

T1_FM02_2684

Figure 2-6
(Sheet 5 of 6)

APS Deployment Handle Cover, above pilot's right shoulder:

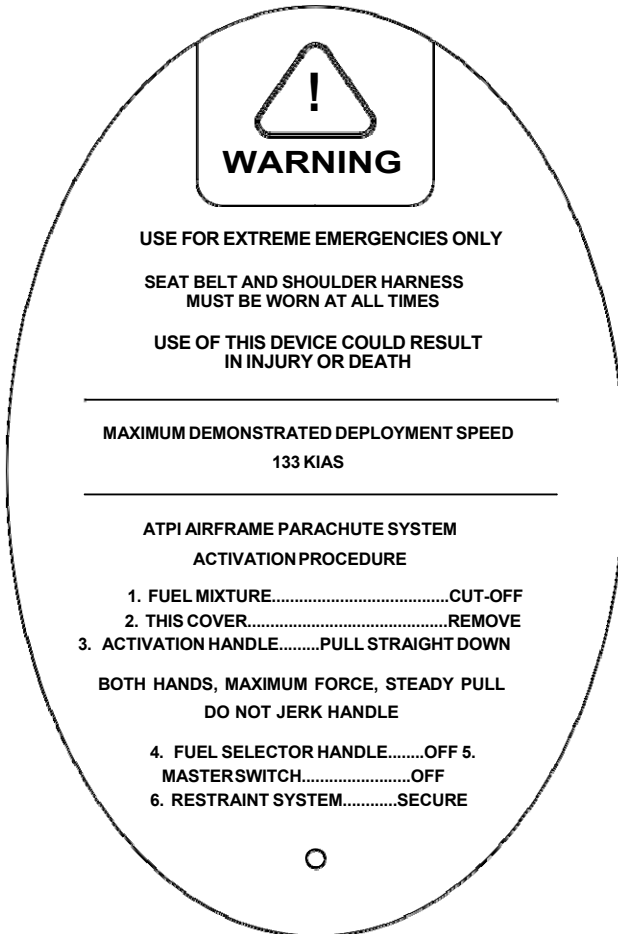

T1_FM02_7

**Figure 2-7
(Sheet 6 of 6)**

Section 3

Emergency Procedures

Table of Contents

Introduction	3
Emergency Procedures Guidance	4
Preflight Planning.....	4
Preflight Inspections/Maintenance	4
Methodology	4
Circuit Breakers	5
Memory Items	5
Airspeeds for Emergency Operations	6
Engine Failures	7
Engine Failure On Takeoff (Low Altitude)	7
Engine Failure In Flight.....	8
Air start	9
Engine Air start	9
Smoke and Fire.....	10
Cabin Fire In Flight	10
Engine Fire In Flight	11
Wing Fire In Flight	12
Engine Fire During Start.....	12
Smoke and Fume Elimination	13
Emergency Descent	14
Emergency Descent	14
Maximum Glide.....	14
Forced Landings	15
Emergency Landing Without Engine Power	15
Ditching.....	16
Landing Without Elevator Control	16
Engine System Emergencies	17
Engine Partial Power Loss.....	17
Oil Pressure Out of Range	19
Oil Temperature High	19
High Cylinder Head Temperature	20
Propeller System Emergencies	21
Engine Speed High.....	21
Propeller Governor Failure	21
Fuel System Emergencies.....	22
High Fuel Flow.....	22

Low Fuel Quantity	22
Electrical System Emergencies	23
High Voltage on Main Bus 1	23
High Voltage on Main Bus 2	24
High or Low Voltage on Essential Bus	25
Environmental System Emergencies	26
Carbon Monoxide Level High	26
Integrated Avionics System Emergencies	27
Attitude & Heading Reference System (AHRS) Failure	27
Air Data Computer (ADC) Failure	27
PFD Display Failure	27
Unusual Attitude Emergencies	28
Inadvertent Spin Entry	28
Inadvertent Spiral Dive During IMC Flight	29
Other Emergencies	30
Power Lever Linkage Failure	30
Emergency Engine Shutdown On Ground	30
Left/Right Brake Over-Temperature Annunciation	31
Starter Engaged Annunciation	31
Emergency Ground Egress	32
APS Deployment	33

Introduction

This section provides procedures for handling emergencies and critical flight situations that may occur while operating the aircraft. Although emergencies caused by airplane, systems, or engine malfunctions are extremely rare, the guidelines described in this section should be considered and applied as necessary should an emergency arise.

• Note •

Emergency procedures associated with optional systems can be found in Section 9.

Emergency Procedures Guidance

Although this section provides procedures for handling most emergencies and critical flight situations that could arise in the aircraft, it is not a substitute for thorough knowledge of the airplane and general aviation techniques. A thorough study of the information in this handbook while on the ground will help you prepare for time-critical situations in the air.

Preflight Planning

Enroute emergencies caused by weather can be minimized or eliminated by careful flight planning and good judgment when unexpected weather is encountered.

Preflight Inspections/Maintenance

In-flight mechanical problems in the aircraft will be extremely rare if proper preflight inspections and maintenance are practiced. Always perform a thorough walk-around preflight inspection before any flight to ensure that no damage occurred during the previous flight or while the airplane was on the ground. Pay special attention to any oil leaks or fuel stains that could indicate engine problems.

Methodology

Aircraft emergencies are very dynamic events. Because of this, it is impossible to address every action a pilot might take to handle a situation. However, four basic actions can be applied to any emergency. They are:

Maintain Aircraft Control — Many minor aircraft emergencies turn into major ones when the pilot fails to maintain aircraft control. Remember, do not panic and do not fixate on a particular problem. Over-attention to a faulty warning light during an instrument approach can lead to a pilot induced unusual attitude and possibly worse. To avoid this, even in an emergency: aviate, navigate, and communicate, in this order. Never let anything interfere with your control of the airplane. Never stop flying.

Analyze the Situation — Once you are able to maintain control of the aircraft, assess the situation. Look at the engine parameters. Listen to the engine. Determine what the airplane is telling you.

Take Appropriate Action — In most situations, the procedures listed in this section will either correct the aircraft problem or allow safe recovery of the aircraft. Follow them and use good pilot judgment.

• Note •

In an in-flight emergency, pressing and holding the COM transfer button for 2 seconds will tune the emergency frequency of 121.500 MHz. If the display is available, it will also show it in the “Active” frequency window.

The ATPI Airframe Parachute System (APS) should be activated in the event of a life-threatening emergency where APS deployment is determined to be safer than continued flight and landing. Refer to Section 10, Safety Information, for APS deployment information and landing considerations.

Land as soon as Conditions Permit — Once you have handled the emergency, assess your next move. Handle any non-critical “clean-up” items in the checklist and put the aircraft on the ground. Remember, even if the airplane appears to be in sound condition, it may not be.

Circuit Breakers

Many procedures involve manipulating circuit breakers. The following criteria should be followed during “Circuit Breaker” steps:

- Circuit breakers that are “SET” should be checked for normal condition. If the circuit breaker is not “Set”, it may be reset only once. If the circuit breaker opens again, do not reset.
- Circuit breakers that “PULL” should only be pulled and not reset.
- Circuit breakers that “CYCLE” should be pulled, delayed for several seconds, and reset only once. Allow sufficient cooling time for circuit breakers that are reset through a “CYCLE” procedure.

Memory Items

Checklist steps emphasized by underlining such as the example below, should be memorized for accomplishment without reference to the procedure.

1. Best Glide Speed..... ESTABLISH

Airspeeds for Emergency Operations

Maneuvering Speed:

3400 lb133 KIAS

Best Glide:

3400 lb88 KIAS

2900 lb87 KIAS

Emergency Landing (Engine-out):

Flaps Up.....90 KIAS

Flaps 50%.....85 KIAS

Flaps 100%.....80 KIAS

Engine Failures

Engine Failure On Takeoff (Low Altitude)

1. Best Glide or Landing Speed (as appropriate) ESTABLISH
 2. MixtureCUTOFF
 3. Fuel Selector..... OFF
 4. Ignition Switch OFF
 5. Flaps AS REQUIRED
- If time permits:*
6. Power Lever IDLE
 7. Fuel PumpOFF
 8. Bat-Alt Master Switches.....OFF
 9. Seat Belts ENSURE SECURED

Amplification

• WARNING •

If engine failure is accompanied by fuel fumes in the cockpit, or if internal engine damage is suspected, move Mixture Control to CUTOFF and do not attempt a restart.

If a turn back to the runway is elected, be very careful not to stall the airplane.

If the engine fails immediately after becoming airborne, abort on the runway if possible. If altitude precludes a runway stop but is not sufficient to restart the engine, lower the nose to maintain airspeed and establish a glide attitude. In most cases, the landing should be made straight ahead, turning only to avoid obstructions. After establishing a glide for landing, perform as many of the checklist items as time permits.

Engine Failure In Flight

1. Best Glide Speed ESTABLISH
2. Mixture AS REQUIRED
3. Fuel Selector SWITCH TANKS
4. Fuel Pump BOOST
5. Alternate Induction Air ON
6. Air Conditioner (if installed) OFF
7. Ignition Switch CHECK, BOTH
8. If engine does not start, proceed to Engine Air start or Forced Landing checklist, as required.

Amplification

• WARNING •

If engine failure is accompanied by fuel fumes in the cockpit, or if internal engine damage is suspected, move Mixture Control to CUTOFF and do not attempt a restart.

If the engine fails at altitude, pitch as necessary to establish best glide speed. While gliding toward a suitable landing area, attempt to identify the cause of the failure and correct it. If altitude or terrain does not permit a safe landing, APS deployment may be required. Refer to Section 10, Safety Information, for APS deployment scenarios and landing considerations.

Air start

Engine Air start

1. Bat Master SwitchesON
2. Power Lever1/2" OPEN
3. Mixture RICH, AS REQ'D
4. Fuel Selector..... SWITCH TANKS
5. Ignition Switch..... BOTH
6. Fuel Pump BOOST
7. Alternate Induction AirON
8. Alt Master SwitchesOFF
9. Starter (Propeller not Wind-milling).....ENGAGE
10. Power Lever slowly INCREASE
11. Alt Master SwitchesON
12. If engine will not start, perform *Forced Landing* checklist.

Amplification

Switching tanks and turning the fuel pump on will enhance starting if fuel contamination was the cause of the failure. Leaning the mixture and then slowly enriching mixture may correct faulty mixture control.

Engine air starts may be performed during 1g flight anywhere within the normal operating envelope of the airplane.

Smoke and Fire

Cabin Fire In Flight

1. Bat-Alt Master Switches OFF, AS REQ'D
2. Fire Extinguisher ACTIVATE
If airflow is not sufficient to clear smoke or fumes from cabin:
3. Cabin Doors PARTIALLY OPEN
Airspeed may need to be reduced to partially open door in flight.
4. Avionics Power Switch OFF
5. All other switches OFF
6. Land as soon as possible.
If setting master switches off eliminated source of fire or fumes and airplane is in night, weather, or IFR conditions:
7. Airflow Selector OFF
8. Bat-Alt Master Switches ON
9. Avionics Power Switch ON
10. Required Systems ACTIVATE one at a time
11. Temperature Selector COLD
12. Vent Selector FEET/PANEL/DEFROST POSITION
13. Airflow Selector SET AIRFLOW TO MAXIMUM
14. Panel Eyeball Outlets OPEN
15. Land as soon as possible.

Amplification

With Bat-Alt Master Switches OFF, engine will continue to run. However, no electrical power will be available.

If the airplane is in IMC conditions, turn ALT 1, ALT 2, and BAT 1 switches OFF. Power from battery 2 will keep the Primary Flight Display operational for approximately 30 minutes. If airplane is in day VFR conditions and turning off the master switches eliminated the fire situation, leave the master switches OFF. Do not attempt to isolate the source of the fire by checking each individual electrical component.

(Continued on following page)

If the cause of the fire is readily apparent and accessible, use the fire extinguisher to extinguish flames and land as soon as possible. Opening the vents or doors may feed the fire, but to avoid incapacitating the crew from smoke inhalation, it may be necessary to rid cabin of smoke or fire extinguishant. If the cause of fire is not readily apparent, is electrical, or is not readily accessible, proceed as follows

If required to re-activate systems. Pause several seconds between activating each system to isolate malfunctioning system. Continue flight to earliest possible landing with malfunctioning system off. Activate only the minimum amount of equipment necessary to complete a safe landing.

Engine Fire In Flight

If an engine fire occurs during flight, do not attempt to restart the engine.

1. MixtureCUTOFF
2. Fuel PumpOFF
3. Fuel Selector..... OFF
4. Airflow Selector.....OFF
5. Power Lever IDLE
6. Ignition Switch.....OFF
7. Cabin Doors.....PARTIALLY OPEN
8. Land as soon as possible.

Amplification

If an engine fire occurs during flight, do not attempt to restart the engine.

Wing Fire In Flight

1. Pitot Heat Switch.....OFF
2. Navigation Light Switch.....OFF
3. Landing LightOFF
4. Strobe Light SwitchOFF
5. If possible, side slip to keep flames away from fuel tank and cabin.
6. Land as soon as possible.

Amplification

• **Caution** •

Putting the airplane into a dive may blow out the fire. Do not exceed V_{NE} during the dive.

Engine Fire During Start

1. Mixture CUTOFF
2. Fuel Pump.....OFF
3. Fuel SelectorOFF
4. Power LeverFORWARD
5. Starter CRANK
6. If flames persist, perform *Emergency Engine Shutdown on Ground* and *Emergency Ground Egress* checklists.

Amplification

A fire during engine start may be caused by fuel igniting in the fuel induction system. If this occurs, attempt to draw the fire back into the engine by continuing to crank the engine.

Smoke and Fume Elimination

1. Air Conditioner (if installed)..... OFF
2. Temperature Selector..... COLD
3. Vent Selector..... FEET/PANEL/DEFROST POSITION
4. Airflow Selector SET AIRFLOW TO MAXIMUM
If source of smoke and fume is firewall forward:
 - a. Airflow Selector OFF
5. Panel Eyeball Outlets..... OPEN
6. Prepare to land as soon as possible.
If airflow is not sufficient to clear smoke or fumes from cabin:
 - a. Cabin Doors PARTIALLY OPEN

Amplification

If smoke and/or fumes are detected in the cabin, check the engine parameters for any sign of malfunction. If a fuel leak has occurred, actuation of electrical components may cause a fire. If there is a strong smell of fuel in the cockpit, divert to the nearest suitable landing field. Perform a *Forced Landing* and shut down the fuel supply to the engine once a safe landing is assured.

Emergency Descent

Emergency Descent

1. Power Lever IDLE
2. Mixture AS REQUIRED
3. Airspeed V_{NE} (200 KIAS)

Amplification

• **Caution** •

If significant turbulence is expected do not descend at indicated airspeeds greater than V_{NO} (177 KIAS)

Maximum Glide

Conditions

Power OFF
Propeller Wind-milling
Flaps 0% (UP)
Wind Zero

Example:

Altitude 10,000 ft. AGL
Airspeed Best Glide
Glide Distance 15.8 NM

Best Glide Speed

88 KIAS at 3400 lb

Maximum Glide Ratio ~ 9.6: 1

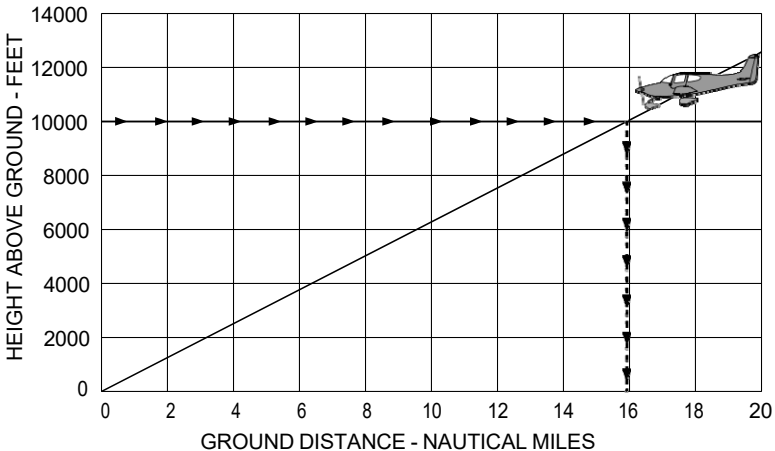

Forced Landings

Emergency Landing Without Engine Power

1. Best Glide Speed..... ESTABLISH
2. Radio Transmit (121.5 MHz) MAYDAY
giving location and intentions
3. Transponder..... SQUAWK 7700
4. If off airport, ELT ACTIVATE
5. Power Lever..... IDLE
6. Mixture.....CUTOFF
7. Fuel Selector..... OFF
8. Ignition Switch.....OFF
9. Fuel PumpOFF
10. Flaps (when landing is assured) 100%
11. Master SwitchesOFF
12. Seat Belt(s)..... SECURED

Amplification

If all attempts to restart the engine fail and a forced landing is imminent, select a suitable field and prepare for the landing. If flight conditions or terrain does not permit a safe landing, APS deployment may be required. Refer to Section 10, Safety Information, for APS deployment scenarios and landing considerations.

A suitable field should be chosen as early as possible so that maximum time will be available to plan and execute the forced landing. For forced landings on unprepared surfaces, use full flaps if possible. Be aware that use of full (100%) flaps will reduce glide distance. Full flaps should not be selected until landing is assured. Land on the main gear and hold the nose wheel off the ground as long as possible.

Ditching

1. Radio..... Transmit (121.5 MHz) MAYDAY giving location and intentions
2. Transponder SQUAWK 7700
3. APS ACTIVATE
4. Airplane..... EVACUATE
5. Flotation Devices..... INFLATE WHEN CLEAR OF AIRPLANE

Amplification

If available, life preservers should be donned and life raft should be prepared for immediate evacuation upon touchdown.

Consider unlatching a door prior to assuming the emergency landing body position in order to provide a ready escape path.

It may be necessary to allow some cabin flooding to equalize pressure on the doors. If the doors cannot be opened, break out the windows with the egress hammer and crawl through the opening.

Landing Without Elevator Control

1. FlapsSET 50%
2. TrimSET 80 KIAS
3. PowerAS REQUIRED FOR GLIDE ANGLE

Amplification

The pitch trim spring cartridge is attached directly to the elevator and provides a backup should you lose the primary elevator control system. Set elevator trim for a 80 KIAS approach to landing. Thereafter, do not change the trim setting until in the landing flare. During the flare, the nose-down moment resulting from a power reduction may cause the airplane to hit on the nosewheel. At touchdown, bring the power lever to idle.

Engine System Emergencies

Engine Partial Power Loss

1. Air Conditioner (if installed)..... OFF
2. Fuel Pump BOOST
3. Fuel Selector..... SWITCH TANKS
4. Mixture CHECK appropriate for flight conditions
5. Power Lever SWEEP
6. Alternate Induction Air ON
7. Ignition Switch..... BOTH, L, then R
8. Land as soon as practical.

Amplification

• WARNING •

If there is a strong smell of fuel in the cockpit, divert to the nearest suitable landing field. Fly a forced landing pattern and shut down the engine fuel supply once a safe landing is assured.

Indications of a partial power loss include fluctuating RPM, reduced or fluctuating manifold pressure, low oil pressure, high oil temperature, and a rough-sounding or rough-running engine. Mild engine roughness in flight may be caused by one or more spark plugs becoming fouled. A sudden engine roughness or misfiring is usually evidence of a magneto malfunction.

A gradual loss of manifold pressure and eventual engine roughness may result from the formation of intake ice. Opening the alternate engine air will provide air for engine operation if the normal source is blocked or the air filter is iced over.

Low oil pressure may be indicative of an imminent engine failure. See *Oil Pressure Out of Range - OIL PRESS Warning* in this section for special procedures with low oil pressure.

A damaged (out-of-balance) propeller may cause extremely rough operation. If an out-of-balance propeller is suspected, immediately shut down engine and perform *Forced Landing* checklist.

If the power loss is due to a fuel leak in the injector system, fuel sprayed over the engine may be cooled by the slipstream airflow which

may prevent a fire at altitude. However, as the Power Lever is reduced during descent and approach to landing the cooling air may not be sufficient to prevent an engine fire.

Selecting BOOST on may clear the problem if vapor in the injection lines is the problem or if the engine-driven fuel pump has partially failed. The electric fuel pump will not provide sufficient fuel pressure to supply the engine if the engine-driven fuel pump completely fails.

Selecting the opposite fuel tank may resolve the problem if fuel starvation or contamination in one tank was the problem.

Cycling the ignition switch momentarily from BOTH to L and then to R may help identify the problem. An obvious power loss in single ignition operation indicates magneto or spark plug trouble. Lean the mixture to the recommended cruise setting. If engine does not smooth out in several minutes, try a richer mixture setting. Return ignition switch to the BOTH position unless extreme roughness dictates the use of a single magneto.

If a partial engine failure permits level flight, land at a suitable airfield as soon as conditions permit. If conditions do not permit safe level flight, use partial power as necessary to set up a forced landing pattern over a suitable landing field. Always be prepared for a complete engine failure and consider APS deployment if a suitable landing site is not available. Refer to Section 10, Safety Information, for APS deployment scenarios and landing considerations.

Oil Pressure Out of Range

OIL PRESS Warning

OIL PRESS

1. Oil Pressure Gage CHECK

If pressure low:

- a. Power REDUCE to minimum for sustained flight
- b. Land as soon as possible.

(1) Prepare for potential engine failure.

If pressure low and oil temperature normal:

- a. Engine MONITOR OIL PRESS/TEMP
- b. Land as soon as practical.

If pressure high:

- a. Power REDUCE to minimum for sustained flight
- b. Land as soon as possible.

(1) Prepare for potential engine failure.

Amplification

If oil pressure is low, the engine has probably lost a significant amount of its oil and engine failure may be imminent.

If oil pressure is suddenly high, a blockage or obstruction may have developed in the oil circulation system and engine failure be imminent.

Oil Temperature High

OIL TEMP Warning

OIL TEMP

1. Power REDUCE
2. Airspeed INCREASE
3. Oil Temperature Gage MONITOR

If temperature remains high:

4. Land as soon as possible.

High Cylinder Head Temperature

CHT Caution and Warning



On-Ground

1. Power LeverREDUCE
2. Annunciations and Engine Temperatures MONITOR
If Caution or Warning annunciation is still illuminated:
3. Power LeverMINIMUM REQUIRED
4. Flight PROHIBITED

In-Flight

1. Power LeverREDUCE
2. Airspeed INCREASE
3. Annunciations and Engine Temperatures MONITOR
If Caution or Warning annunciation is still illuminated:
4. Power LeverMINIMUM REQUIRED
5. Engine Instruments MONITOR
If Caution annunciation only remains illuminated:
 - a. Land as soon as practical.*If Warning annunciation remains illuminated:*
 - a. Land as soon as possible.

Propeller System Emergencies

Engine Speed High

RPM Warning: Engine Speed High



1. Tachometer CHECK
If engine speed normal:
 - a. If On-Ground CORRECT PRIOR TO FLIGHT
 - b. If In-Flight CONTINUE, MONITOR*If engine speed high:*
 - a. PowerREDUCE
 - b. AirspeedREDUCE UNTIL RPM BELOW 2700
2. Oil Pressure Gage CHECK

Propeller Governor Failure

Propeller RPM will not increase:

1. Oil Pressure CHECK
2. Land as soon as practical.

Propeller over-speeds or will not decrease:

1. Power LeverADJUST (to keep RPM in limits)
2. Airspeed.....REDUCE to 90 KIAS
3. Land as soon as practical.

Amplification

If the RPM does not respond to power lever movement or over-speeds, the most likely cause is a faulty governor or an oil system malfunction. If moving the power lever is difficult or rough, suspect a power lever linkage failure and perform the *Power Lever Linkage Failure* checklist.

Fuel System Emergencies

High Fuel Flow

FUEL FLOW Warning

FUEL FLOW

Fuel flow greater than 30 GPH.

On-Ground

1. Correct prior to flight.

In-Flight

1. MixtureADJUST

Adjust engine operation to correct condition. Check engine instruments to verify HIGH FLOW Warning is not erroneous, i.e. abnormal engine temperatures or engine roughness after mixture adjustment.

If FUEL FLOW Warning does not extinguish:

2. Land as soon as practical.

Low Fuel Quantity

FUEL QTY Warning

FUEL QTY

1. Fuel Quantity Gages CHECK

If fuel quantity indicates less than or equal to 9 gallons:

- a. If On-Ground.....REFUEL PRIOR TO FLIGHT
- b. If In-Flight..... LAND AS SOON AS PRACTICAL

If fuel quantity indicates more than 9 gallons:

- a. If On-Ground..... CORRECT PRIOR TO FLIGHT
- b. If In-Flight..... CONTINUE, MONITOR

Amplification

Fuel Totalizer quantity less than or equal to 9 gallons.

Electrical System Emergencies

High Voltage on Main Bus 1

M BUS 1 Warning



- 1. ALT 1 Master Switch CYCLE
- 2. M Bus 1 Voltage (M1) CHECK
If M Bus 1 Voltage is greater than 32 volts
- 3. ALT 1 Master Switch OFF
- 4. Perform Alt 1 Caution (Failure) Checklist (do not reset alternator)

Amplification

Main Bus 1 Voltage is excessive, indicates an alternator 1 voltage regulator failure; will typically be associated with abnormally high voltage indications on M1, M2 and ESS busses, may also be associated with M Bus 2 or ESS BUS Warning message.

High Voltage on Main Bus 2

M BUS 2 Warning

M BUS 2

1. Main Bus 1 Voltage (M1)..... CHECK
If M Bus 1 Voltage is greater than 32 volts
2. Perform M Bus 1 Warning Checklist
3. Main Bus 2 Voltage (M2)..... CHECK
If M Bus 2 Voltage is greater than 32 Volts:
4. ALT 2 Master Switch CYCLE
5. Main Bus 2 Voltage (M2)..... CHECK
If M Bus 2 Voltage remains greater than 32 volts
6. ALT 2 Master Switch OFF
7. Perform Alt 2 Caution (Failure) Checklist (do not reset alternator)

Amplification

Main Bus 2 Voltage is excessive. Indicates an alternator voltage regulator failure; will typically be associated with abnormally high bus voltage indications on M2 and ESS, may also be associated with M BUS 1 and ESS BUS Warning Messages.

High or Low Voltage on Essential Bus

ESS BUS Warning

ESS BUS

1. Essential Bus Voltage (ESS)..... CHECK
If Essential Bus Voltage is greater than 32 volts:
2. Main Bus 1 and Main Bus 2 Voltages (M1 and M2)..... CHECK
3. Perform appropriate *Main Bus 1* or *Main Bus 2* Warning checklists
If Essential Bus Voltage is less than 24.5 volts:
4. Perform Alt 1 and Alt 2 Caution (Failure) checklists
If unable to restore at least one alternator:
5. Non-Essential Loads.....REDUCE
 - a. If flight conditions permit, consider shedding:
Air Conditioning, Landing Light, Pitot Heat, Cabin Fan, Nav Lights, Strobe Lights, Audio Panel, COM 2.
6. Land as soon as practical (Battery reserve only)

Amplification

• Caution •

Dependent on battery state, flaps and landing light may be unavailable on landing.

Essential Bus voltage is high or low. High voltage indicates alternator voltage regulator failure; will typically be associated with high M1 and/ or M2 voltages and M BUS 1 and/or M BUS 2 warning messages.

Low voltage indicates dual failures of Alternators 1 and 2, will typically be associated with low M1 and M2 voltages, M BUS 1 and M BUS 2 Caution messages, and Alt 1 and Alt 2 Caution messages.

Environmental System Emergencies

Carbon Monoxide Level High

CO LVL HIGH Warning

CO LVL HIGH

1. Air Conditioner (if installed).....OFF
2. Temperature Selector.....COLD
3. Vent Selector..... FEET/PANEL/DEFROST POSITION
4. Airflow Selector SET AIRFLOW TO MAXIMUM
5. Panel Eyeball OutletsOPEN

If CO LVL HIGH does not extinguish:

6. Supplemental Oxygen (if available)
 - a. Oxygen Masks or Cannulas DON
 - b. Oxygen System ON
 - c. Oxygen Flow Rate MAXIMUM
7. Cabin Doors PARTIALLY OPEN
8. Land as soon as possible.

Amplification

Annunciation indicates carbon monoxide level is greater than 50 PPM. Ensure that air condition is not in recirculate mode and that air temperature is set to full COLD to supply maximum amount of fresh air to cabin.

Integrated Avionics System Emergencies

A “Red X” through any electronic display field, such as COM frequencies, NAV frequencies, or engine data, indicates that display field is not receiving valid data.

Attitude & Heading Reference System (AHRS) Failure

1. Verify Avionics System has switched to functioning AHRS
If not, manually switch to functioning AHRS and attempt to bring failed AHRS back on-line:
2. Failed AHRS Circuit Breaker.....SET
If open, reset (close) circuit breaker. If circuit breaker opens again, do not reset.
3. Be prepared to revert to Standby Instruments (Altitude, Heading).

Amplification

Failure of the Attitude and Heading Reference System (AHRS) is indicated by removal of the sky/ground presentation and a “Red X” and a yellow “ATTITUDE FAIL” shown on the PFD. The digital heading presentation will be replaced with a yellow “HDG” and the compass rose digits will be removed. The course pointer will indicate straight up and course may be set using the digital window.

Air Data Computer (ADC) Failure

1. ADC Circuit Breaker.....SET
If open, reset (close) circuit breaker. If circuit breaker opens again, do not reset.
2. Revert to Standby Instruments (Altitude, Airspeed).
3. Land as soon as practical.

Amplification

Complete loss of the Air Data Computer is indicated by a “Red X” and yellow text over the airspeed, altimeter, vertical speed, TAS and OAT displays. Some FMS functions, such as true airspeed and wind calculations, will also be lost.

PFD Display Failure

1. Display Backup ACTIVATE
2. Land as soon as practical.

Unusual Attitude Emergencies

Inadvertent Spin Entry

1. APSACTIVATE

Amplification

• WARNING •

In all cases, if the aircraft enters an unusual attitude from which recovery is not expected before ground impact, ***immediate*** deployment of the APS is required.

The minimum demonstrated altitude loss for a APS deployment from a one-turn spin is 920 feet. Activation at higher altitudes provides enhanced safety margins for parachute recoveries. Do not waste time and altitude trying to recover from a spiral/spin before activating APS.

The aircraft is not approved for spins, and has not been tested or certified for spin recovery characteristics. The only approved and demonstrated method of spin recovery is activation of the ATPI Airframe Parachute System (See APS Deployment, this section). Because of this, if the aircraft “departs controlled flight,” the APS must be deployed.

While the stall characteristics of the aircraft make accidental entry into a spin extremely unlikely, it is possible. Spin entry can be avoided by using good airmanship: coordinated use of controls in turns, proper airspeed control following the recommendations of this Handbook, and never abusing the flight controls with accelerated inputs when close to the stall (see Stalls, Section 4).

If, at the stall, the controls are misapplied and abused accelerated inputs are made to the elevator, rudder and/or ailerons, an abrupt wing drop may be felt and a spiral or spin may be entered. In some cases, it may be difficult to determine if the aircraft has entered a spiral or the beginning of a spin.

Inadvertent Spiral Dive During IMC Flight

1. Power Lever IDLE
2. Stop the spiral dive by using coordinated aileron and rudder control while referring to the attitude indicator and turn coordinator to level the wings.
3. Cautiously apply elevator back pressure to bring airplane to level flight attitude.
4. Trim for level flight.
5. Set power as required.
6. Use autopilot if functional otherwise keep hands off control yoke, use rudder to hold constant heading.
7. Exit IMC conditions as soon as possible.

Amplification

In all cases, if the aircraft enters an unusual attitude from which recovery is not assured, immediately deploy APS. Refer to Section 10, Safety Information, for APS deployment information.

Other Emergencies

Power Lever Linkage Failure

1. Power Lever Movement.....VERIFY
2. Power SET if able
3. Flaps SET if needed
4. Mixture AS REQUIRED (full rich to cut-off)
5. Land as soon as possible.

Amplification

If the Power Lever linkage fails in flight, the engine will not respond to power lever control movements. Use power available and flaps as required to safely land the airplane.

If the power lever is stuck at or near the full power position, proceed to a suitable airfield. Fly a forced landing pattern. With landing assured, shut down engine by moving mixture control full aft to CUTOFF. If power is needed again, return mixture control to full RICH and regain safe pattern parameters or go-around. If airspeed cannot be controlled, shut engine down and perform the *Forced Landing* checklist. After landing, bring the airplane to a stop and complete the Emergency Engine Shutdown on Ground checklist.

If the power lever is stuck at or near the idle position and straight and level flight cannot be maintained, establish glide to a suitable landing surface. Fly a forced landing pattern.

Emergency Engine Shutdown On Ground

1. Power Lever IDLE
2. Fuel Pump (if used).....OFF
3. Mixture CUTOFF
4. Fuel SelectorOFF
5. Ignition Switch.....OFF
6. Bat-Alt Master Switches.....OFF

Left/Right Brake Over-Temperature Annunciation***BRAKE TEMP Warning***

BRAKE TEMP

1. Stop aircraft and allow the brakes to cool.

Amplification

Annunciation indicates brake temperature is greater than 293°F. Refer to Section 10 - Safety Information: Taxiing, Steering, and Braking Practices for additional information

Starter Engaged Annunciation***STARTER ENGAGED Warning***

START ENGAGE

On-Ground

1. Ignition Switch.....DISENGAGE
2. Battery Switches Wait 1 minute before next start attempt
If starter does not disengage (relay or solenoid failure):
3. BAT 1 Switch.....OFF
4. Engine..... SHUTDOWN
5. STARTER Circuit breaker PULL

In-Flight

1. Ignition Switch..... Ensure not stuck in START
2. STARTER Circuit breaker PULL
3. Flight CONTINUE
Engine start will not be available at destination.

(Continued on following page)

Amplification

• WARNING •

Use extreme caution after shutdown if STARTER circuit breaker required pull (failed relay or solenoid). If breaker is unknowingly or unintentionally reset, starter will instantly engage if Battery 1 power is supplied; creating a hazard for ground personnel.

Starter has been engaged for more than 15 seconds (starter limit is 20 seconds); if not manually engaged, such as during difficult start, this annunciation may indicate a failure of the starter solenoid or a stuck key switch.

Emergency Ground Egress

1. Engine.....SHUTDOWN
2. Seat belts RELEASE
3. Airplane.....EXIT

Amplification

• WARNING •

While exiting the airplane, make sure evacuation path is clear of other aircraft, spinning propellers, and other hazards.

If the engine is left running, set the Parking Brake prior to evacuating the airplane.

If the doors cannot be opened, break out the windows with egress hammer, located in the console between the front seats, and crawl through the opening.

APS Deployment

1. Airspeed..... MINIMUM POSSIBLE
The maximum demonstrated deployment speed is 133 KIAS.
2. Mixture (If time and altitude permit)CUTOFF
3. Activation Handle Cover.....REMOVE
4. Activation Handle (Both Hands).....PULL STRAIGHT DOWN

After Deployment:

5. Mixture CHECK, CUTOFF
6. Fuel Selector..... OFF
7. Bat-Alt Master Switches..... OFF
8. Ignition Switch..... OFF
9. Fuel Pump OFF
10. ELT ON
11. Seat Belts and Harnesses TIGHTEN
12. Loose Items SECURE
13. Assume emergency landing body position.
14. After the airplane comes to a complete stop, evacuate quickly and move upwind.

Amplification

• WARNING •

APS deployment is expected to result in loss of the airframe and, depending upon adverse external factors such as high deployment speed, low altitude, rough terrain or high wind conditions, may result in severe injury or death to the occupants. Because of this, APS should only be activated when any other means of handling the emergency would not protect the occupants from serious injury.

Jerking or rapidly pulling the activation T-handle will greatly increase the pull forces required to activate the rocket. Use a firm and steady pulling motion – a “chin-up” type pull enhances successful activation.

The ATPI Airframe Parachute System (APS) should be activated in the event of a life-threatening emergency where APS deployment is determined to be safer than continued flight and landing.

Expected impact in a fully stabilized deployment is equivalent to a drop from approximately 13 feet.

Several possible scenarios in which the activation of the APS would be appropriate are discussed in Section 10 - Safety Information, of this Handbook. These include:

- Mid-air collision
- Structural failure
- Loss of control
- Landing in inhospitable terrain
- Pilot incapacitation

All pilots should carefully review the information on APS activation and deployment in Section 10 before operating the airplane.

Section 3A

Abnormal Procedures

Table of Contents

Introduction	3
Abnormal Procedures Guidance	3
Circuit Breakers	3
Flight Environment	4
Inadvertent Icing Encounter	4
Inadvertent IMC Encounter	4
Door Open In Flight	4
Abnormal Landings	5
Landing With Failed Brakes	5
Landing With Flat Tire	5
Engine System	6
Low Idle Oil Pressure	6
Starter Engaged Annunciation	7
Fuel System	8
Low Fuel Quantity	8
Left Fuel Tank Quantity	8
Right Fuel Tank Quantity	9
Fuel Filter in Bypass Mode	9
Electrical System	10
Low Voltage on Main Bus 1	10
Low Voltage on Main Bus 2	10
Battery 1 Current Sensor	10
Low Alternator 1 Output	11
Low Alternator 2 Output	12
Integrated Avionics System	13
Avionics Switch Off	13
PFD Cooling Fan Failure	13
MFD Cooling Fan Failure	13
Flight Displays Too Dim	14
Pitot Static System	15
Pitot Static Malfunction	15
Pitot Heat Current Sensor Annunciation	16
Pitot Heat Required Annunciation	16
Flight Control System	17
Electric Trim/Autopilot Failure	17
Flap System Exceedance	17

Landing Gear System 18
 Brake Failure During Taxi 18
 Left/Right Brake Over-Temperature 18
Other Conditions 19
 Aborted Takeoff 19
 Parking Brake Engaged Annunciation..... 20
 Communications Failure 20

Introduction

This section provides procedures for handling abnormal system and/or flight conditions which, if followed, will maintain an acceptable level of airworthiness or reduce operational risk. The guidelines described in this section are to be used when an abnormal condition exists and should be considered and applied as necessary.

• Caution •

If a Warning annunciation is illuminated in combination with any of the following Abnormal annunciations, the Warning annunciation takes precedents and shall be performed first.

Abnormal Procedures Guidance

Although this section provides procedures for handling most abnormal system and/or flight conditions that could arise in the aircraft, it is not a substitute for thorough knowledge of the airplane and general aviation techniques. A thorough study of the information in this handbook while on the ground will help you prepare for time-critical situations in the air.

Sound judgement as well as thorough knowledge of the aircraft, its characteristics, and the flight manual procedures are essential in the handling of any abnormal system and/or flight condition. In addition to the outlined items in the Abnormal Procedures, the following steps are considered part of all abnormal situations:

- ***Maintain Aircraft Control***
- ***Analyze the Situation***
- ***Take Appropriate Action***

Circuit Breakers

Many procedures involve manipulating circuit breakers. The following criteria should be followed during “Circuit Breaker” steps:

- Circuit breakers that are “SET” should be checked for normal condition. If the circuit breaker is not “Set”, it may be reset only once. If the circuit breaker opens again, do not reset.
- Circuit breakers that “PULL” should only be pulled and not reset.
- Circuit breakers that “CYCLE” should be pulled, delayed for several seconds, and reset only once. Allow sufficient cooling time for circuit breakers that are reset through a “CYCLE” procedure.

Flight Environment

Inadvertent Icing Encounter

1. Pitot Heat ON
2. Exit icing conditions. Turn back or change altitude.
3. Cabin Heat MAXIMUM
4. Windshield Defrost FULL OPEN
5. Alternate Induction Air ON

Amplification

Flight into known icing conditions is prohibited.

Inadvertent IMC Encounter

1. Airplane Control ESTABLISH straight and level flight
2. Autopilot ENGAGE to hold heading and altitude
3. Heading RESET to initiate 180° turn

Amplification

Upon entering IMC, a pilot who is not completely proficient in instrument flying should rely upon the autopilot to execute a 180° turn to exit the conditions. Immediate action should be made to turn back as described above:

Door Open In Flight

The doors on the airplane will remain 1-3 inches open in flight if not latched. If this is discovered on takeoff roll, abort takeoff if practical. If already airborne do not allow efforts to close the door interfere with the primary task of maintaining control of the airplane. Do not attempt to hold door closed. Upon landing flare door may swing open - do not attempt to close door.

1. Airplane Control MAINTAIN

Abnormal Landings

Landing With Failed Brakes

One brake inoperative

1. Land on the side of runway corresponding to the inoperative brake.
2. Maintain directional control using rudder and working brake.

Both brakes inoperative

1. Divert to the longest, widest runway with the most direct headwind.
2. Land on downwind side of the runway.
3. Use the rudder for obstacle avoidance.
4. Perform *Emergency Engine Shutdown on Ground* checklist.

Amplification

Rudder effectiveness will decrease with decreasing airspeed.

Landing With Flat Tire

Main Gear

1. Land on the side of the runway corresponding to the good tire.
2. Maintain directional control with the brakes and rudder.
3. Do not taxi. Stop the airplane and perform a normal engine shutdown.

Nose Gear

1. Land in the center of the runway.
2. Hold the nosewheel off the ground as long as possible.
3. Do not taxi. Stop the airplane and perform a normal engine shutdown.

Amplification

If a flat tire or tread separation occurs during takeoff and you cannot abort, land as soon as conditions permit.

Engine System

Low Idle Oil Pressure

OIL PRESS Caution



1. If In-Flight.....LAND as soon as practical

Amplification

Oil pressure between 10 psi and 30 psi at or above 1000 RPM

This message will appear prior to engine start and should clear after engine start.

Starter Engaged Annunciation

STARTER ENGAGED Caution

START ENGAGE

On-Ground

1. Ignition Switch.....DISENGAGE prior to 20 Seconds
2. Battery SwitchesWait 20 seconds before next start attempt
If starter does not disengage (relay or solenoid failure):
3. BAT 1 Switch.....OFF
4. Engine.....SHUTDOWN
5. STARTER Circuit breakerPULL

In-Flight

1. Ignition Switch..... Ensure not stuck in START
2. STARTER Circuit breakerPULL
3. Flight..... CONTINUE
Engine start will not be available at destination.

Amplification

• WARNING •

Use extreme caution after shutdown if STARTER circuit breaker required pull (failed relay or solenoid). If breaker is unknowingly or unintentionally reset, starter will instantly engage if Battery 1 power is supplied; creating a hazard for ground personnel.

Starter has been engaged for more than 15 seconds (starter limit is 20 seconds); if not manually engaged, such as during difficult start, this annunciation may indicate a failure of the starter solenoid or a stuck key switch.

Fuel System

Low Fuel Quantity

FUEL QTY Caution

FUEL QTY

1. Fuel Quantity Gages CHECK

If fuel quantity indicates less than or equal to 14 gallons:

- a. Land as soon as practical.

If fuel quantity indicates more than 14 gallons:

- a. Flight..... CONTINUE, MONITOR

Amplification

Annunciation indicates fuel quantity is less than or equal to 14 gallons.

Left Fuel Tank Quantity

L FUEL QTY Advisory

L FUEL QTY

1. Left Fuel Quantity Gage CHECK

If left fuel quantity indicates less than or equal to 14 gallons:

- a. If On-Ground.....REFUEL PRIOR TO FLIGHT

- b. If In-Flight..... CONTINUE, MONITOR

If left fuel quantity indicates more than 14 gallons:

- a. If On-Ground..... CORRECT PRIOR TO FLIGHT

- b. If In-Flight..... CONTINUE, MONITOR

Right Fuel Tank Quantity***R FUEL QTY Advisory*****R FUEL QTY**

1. Right Fuel Quantity Gage CHECK
If right fuel quantity indicates less than or equal to 14 gallons:
 - a. If On-Ground REFUEL PRIOR TO FLIGHT
 - b. If In-Flight CONTINUE, MONITOR*If right fuel quantity indicates more than 14 gallons:*
 - a. If On-Ground CORRECT PRIOR TO FLIGHT
 - b. If In-Flight CONTINUE, MONITOR

Amplification

Right fuel quantity is less than or equal to 14 gallons.

Fuel Filter in Bypass Mode***FUEL FILTER Advisory*****FUEL FILTER**

1. If In-Flight..... LAND AS SOON AS PRACTICAL
2. Replace fuel filter element prior to next flight.

Amplification

The fuel filter is in bypass mode. The fuel filter element must be replaced.

Electrical System

Low Voltage on Main Bus 1

M BUS 1 Caution

M BUS 1

1. Perform Alt 1 Caution (Failure) Checklist.

Amplification

Main Bus 1 Voltage is low, indicates Alt 1 failure; will typically be associated with low M1 voltage Alt 1 current indications, Battery 1 discharge and ALT 1 Caution message.

Low Voltage on Main Bus 2

M BUS 2 Caution

M BUS 2

1. Perform Alt 1 and Alt 2 Caution (Failure) checklists.

Amplification

Main Bus 2 Voltage is low, indicative of dual Alt 1 and 2 failures; will typically be associated with low M1 and M2 voltages, Alt 1 and Alt 2 current indications, Battery 1 discharge, ALT 1 & 2 and M BUS 1 & 2 Caution messages, and ESS BUS Warning message.

Battery 1 Current Sensor

BATT 1 Caution

BATT 1

1. Main Bus 1, 2 and Non-Essential Bus Loads.....REDUCE
2. Main Bus 1, 2 and Essential Bus Voltages.....MONITOR
3. Land as soon as practical.

Amplification

Battery 1 discharge while Alt 1 is functioning normally, indicative of an internal power distribution failure within the MCU

Low Alternator 1 Output

ALT 1 Caution (Failure)

ALT 1

1. ALT 1 Circuit Breaker CHECK & SET
2. ALT 1 Master Switch CYCLE
If alternator does not reset (low A1 Current and M1 voltage):
3. ALT 1 Master Switch OFF
4. Non-Essential Bus Loads REDUCE
 - a. If flight conditions permit, consider shedding the following to preserve Battery 1:
 - (1) Air Conditioning,
 - (2) Landing Light,
 - (3) Yaw Servo,
 - (4) Convenience Power (aux items plugged into armrest jack)
5. Continue Flight, avoiding IMC or night flight as able (reduced power redundancy).

Amplification

• Caution •

Dependent on Battery 1 state (indicated by M1 voltage), landing light may be weak or inoperative for landing.

Alternator 1 output is low, indicative of alternator failure; will typically be associated with low M1 voltage, Battery 1 discharge and M BUS 1 Caution message.

Low Alternator 2 Output

ALT 2 Caution (Failure)

ALT 2

1. ALT 2 Circuit BreakerCHECK & SET
2. ALT 2 Master SwitchCYCLE
If alternator does not reset (low A2 Current and M2 voltage less than M1 voltage):
3. ALT 2 Master SwitchOFF
4. Continue Flight, avoiding IMC or night flight as able (reduced power redundancy).

Amplification

Alternator 2 output is low, indicative of alternator failure; isolated Alt 2 failure will not typically be associated with any other unusual indications, cautions or warnings (Alt 1 will pick up all loads).

Integrated Avionics System

Avionics Switch Off

AVIONICS OFF Caution

AVIONICS OFF

1. AVIONICS Switch ON, AS REQUIRED

Amplification

The AVIONICS master switch is off.

PFD Cooling Fan Failure

PFD 1 FAN FAIL Advisory

PFD 1 FAN FAIL

1. AVIONICS FAN 2 Circuit Breaker CYCLE

If annunciation does not extinguish:

- a. Hot cabin temperatures LAND AS SOON AS PRACTICAL
- b. Cool cabin temperatures CONTINUE, MONITOR

Amplification

The cooling fan for the PFD is inoperative.

MFD Cooling Fan Failure

MFD FAN FAIL Advisory

MFD FAN FAIL

1. AVIONICS FAN 1 Circuit Breaker CYCLE

If annunciation does not extinguish:

- a. High cabin temperatures LAND AS SOON AS PRACTICAL
- b. Low cabin temperatures CONTINUE, MONITOR

Amplification

The cooling fan for the MFD is inoperative.

Flight Displays Too Dim

1. INSTRUMENT dimmer knob OFF (full counter-clockwise)
If flight displays do not provide sufficient brightness:
2. Revert to standby instruments.

Amplification

The instrument dimmer knob provides manual dimming control of the display screens, key and text backlighting, flap and Environmental Control System (ECS) status indicators, and standby instruments. Rotation of the dimmer knob fully counterclockwise disables the dimmer, and reverts to daytime lighting for all components.

In daytime lighting (knob OFF/full counterclockwise):

- Standby instruments, all Avionics system keypads and the bolster switch panel are unlit
- MFD and PFD screen illumination is controlled by automatic photocell (providing full brightness in high light conditions, only slightly reduced by darkness)
- ECS and control panels are backlight and their status lights at maximum intensity

With active dimming (knob moved clockwise), the full bright position (full clockwise) applies maximum illumination to keys and switches, to standby instruments and to status lights, but the PFD/MFD screen illumination is at a substantially reduced level (levels still appropriate for night flight). Maximum screen illumination (appropriate for daytime use) is with the dimmer OFF/full counterclockwise.

Pitot Static System

Pitot Static Malfunction

Static Source Blocked

1. Pitot HeatON
2. Alternate Static Source OPEN

Amplification

If erroneous readings of the static source instruments (airspeed, altimeter and vertical speed) are suspected, the alternate static source valve, on side of console near pilot's right ankle, should be opened to supply static pressure from the cabin to these instruments. With the alternate static source on, adjust indicated airspeed slightly during climb or approach according to the Airspeed Calibration (Alternate Static Source) table in Section 5 as appropriate for vent/ heater configuration.

Pitot Tube Blocked

1. Pitot HeatON

Amplification

If only the airspeed indicator is providing erroneous information, and in icing conditions, the most probable cause is Pitot ice. If setting Pitot Heat ON does not correct the problem, descend to warmer air. If an approach must be made with a blocked Pitot tube, use known pitch and power settings and the GPS groundspeed indicator, taking surface winds into account.

Pitot Heat Current Sensor Annunciation

PITOT HEAT FAIL Caution

PITOT HEAT FAIL

1. Pitot Heat Circuit Breaker.....CYCLE
2. Pitot HeatCYCLE OFF, ON
If inadvertent icing encountered, perform Inadvertent Icing Encounter Emergency Checklist and:
 - a. AirspeedEXPECT NO RELIABLE INDICATION
 - b. Exit icing conditions using attitude, altitude, and power instruments.

Amplification

Pitot heat failure. Displayed when Pitot heat switch is ON and Pitot heat current is not detected.

Pitot Heat Required Annunciation

PITOT HEAT REQUIRED Caution

PITOT HEAT REQD

1. Pitot Heat ON

Amplification

Displayed 20 seconds after system detects OAT is less than 41°F (5°C) and Pitot Heat Switch is OFF.

Flight Control System

Electric Trim/Autopilot Failure

1. Airplane Control.....MAINTAIN MANUALLY
2. Autopilot (if engaged).....DISENGAGE
If Problem Is Not Corrected:
3. Circuit Breakers PULL AS REQUIRED
 - PITCH TRIM
 - ROLL TRIM
 - YAW SERVO
 - AP SERVOS
4. Power Lever AS REQUIRED
5. Control Yoke.....MANUALLY HOLD PRESSURE
6. Land as soon as practical.

Amplification

Any failure or malfunction of the electric trim or autopilot can be overridden by use of the control yoke. If runaway trim is the problem, de-energize the circuit by pulling the appropriate circuit breakers and land as soon as conditions permit.

Flap System Exceedance

FLAPS Caution

FLAPS

1. Airspeed.....REDUCE
or
1. Flaps RETRACT

Amplification

Flaps are extended beyond airspeed limitations.

Flaps at 100%, airspeed greater than 109 KIAS for 5 seconds or more,
OR

Flaps at 50%, airspeed greater than 124 KIAS for 5 seconds or more.

Landing Gear System

Brake Failure During Taxi

1. Engine Power AS REQUIRED
 - To stop airplane - REDUCE
 - If necessary for steering - INCREASE
2. Directional Control MAINTAIN WITH RUDDER
3. Brake Pedal(s)..... PUMP
If directional control cannot be maintained:
4. Ignition Switch OFF

Amplification

Ground steering is accomplished by differential braking. However, increasing power may allow some rudder control due to increased groundspeed and airflow over the rudder.

Left/Right Brake Over-Temperature

BRAKE TEMP Caution



1. Stop aircraft and allow the brakes to cool.

Amplification

Brake temperature is between 270°F and 293°F for more than 5 seconds. Refer to Section 10 - Safety Information: Taxiing, Steering, and Braking Practices for additional information.

Other Conditions

Aborted Takeoff

1. Power Lever IDLE
2. Brakes..... AS REQUIRED

Amplification

Use as much of the remaining runway as needed to safely bring the airplane to a stop or to slow the airplane sufficiently to turn off runway.

• Caution •

For maximum brake effectiveness, retract flaps, hold control yoke full back, and bring the airplane to a stop by smooth, even application of the brakes.

After a high-speed aborted takeoff, brake temperatures will be elevated; subsequent aborted takeoffs or other high-energy use of the brakes may cause brake overheat, failure and possibly even fire. A 25-minute cooling time is recommended following high-energy use of the brake system before attempting to conduct operations that may require further high-energy braking. Brake temperature indicator should be inspected prior to flight following a high-energy brake event (refer to Preflight Walk-Around Checklist for detail).

Parking Brake Engaged Annunciation

PARK BRAKE Caution

PARK BRAKE

1. Parking Brake..... RELEASE
2. Monitor CAS for BRAKE TEMP Caution. Stop aircraft and allow the brakes to cool if necessary.

Amplification

Parking brake is set.

Communications Failure

1. Switches, Controls CHECK
2. Frequency CHANGE
3. Circuit Breakers..... SET
4. Headset..... CHANGE
5. Hand Held Microphone CONNECT

Amplification

If, after following the checklist procedure, communication is not restored, proceed with FAR/AIM lost communications procedures.

• Note •

In the event of an audio panel power failure the audio panel connects COM 1 to the pilot's headset and speakers. Setting the audio panel 'Off' will also connect COM 1 to the pilot's headsets and speakers.

Section 4

Normal Procedures

Table of Contents

Introduction	3
Airspeeds for Normal Operation	3
Normal Procedures	4
Preflight Inspection	4
Preflight Walk-Around	4
Before Starting Engine	9
Starting Engine	10
Before Taxiing	12
Taxiing	12
Before Takeoff	13
Maximum Power Fuel Flow	15
Takeoff	16
Normal Takeoff	16
Short Field Takeoff	17
Climb	17
Cruise	18
Cruise Leaning	19
Descent	19
Before Landing	19
Landing	20
Balked Landing/Go-Around	21
After Landing	21
Shutdown	22
Stalls	23
Environmental Considerations	24
Cold Weather Operation	24
Hot Weather Operation	26
Noise Characteristics/Abatement	27
Fuel Conservation	27

Intentionally Left Blank

Introduction

This section provides amplified procedures for normal operation. Normal procedures associated with optional systems can be found in Section 9.

Airspeeds for Normal Operation

Unless otherwise noted, the following speeds are based on a maximum weight of 3400 lb. and may be used for any lesser weight. However, to achieve the performance specified in Section 5 for takeoff and landing distance, the speed appropriate to the particular weight must be used.

Takeoff Rotation:

- Normal, Flaps 50% 70 KIAS
- Obstacle Clearance, Flaps 50% 78 KIAS

Enroute Climb, Flaps Up:

- Normal 110-120 KIAS
- Best Rate of Climb, SL 101 KIAS
- Best Rate of Climb, 10,000 96 KIAS
- Best Angle of Climb, SL 79 KIAS
- Best Angle of Climb, 10,000 83 KIAS

Landing Approach:

- Normal Approach, Flaps Up 90-95 KIAS
- Normal Approach, Flaps 50% 85-90 KIAS
- Normal Approach, Flaps 100% 80-85 KIAS
- Short Field, Flaps 100% (V_{REF}) 77 KIAS

Go-Around, Flaps 50%:

- Full Power 80 KIAS

Maximum Recommended Turbulent Air Penetration:

- 3400 lb 133 KIAS
- 2900 lb 123 KIAS

Maximum Demonstrated Crosswind Velocity:

- Takeoff or Landing 20 Knots

Normal Procedures

Preflight Inspection

Before carrying out preflight inspections, ensure that all required maintenance has been accomplished. Review your flight plan and compute weight and balance.

• Note •

Throughout the walk-around: check all hinges, hinge pins, and bolts for security; check skin for damage, condition, and evidence of delamination; check all control surfaces for proper movement and excessive free play; check area around liquid reservoirs and lines for evidence of leaking.

In cold weather, remove all frost, ice, or snow from fuselage, wing, stabilizers and control surfaces. Ensure that control surfaces are free of internal ice or debris. Check that wheel fairings are free of snow and ice accumulation. Check that Pitot probe warms within 30 seconds of setting Pitot Heat to ON.

Preflight Walk-Around

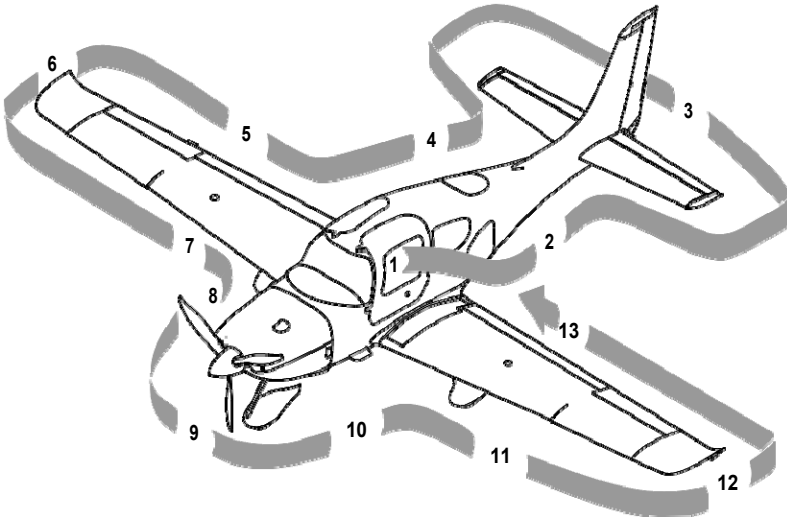

T1_FM04_1454

1. Cabin
 - a. Required Documents.....On Board
 - b. Avionics Power Switch..... OFF
 - c. Bat 2 Master SwitchON
 - d. PFD Verify On
 - e. Essential Bus Voltage..... 23-25 Volts
 - f. Flap Position Light OUT
 - g. Bat 1 Master SwitchON
 - h. Avionics Cooling Fan Audible
 - i. Lights..... Check Operation
 - j. Stall Warning Test

• Note •

Test stall warning system by applying suction to the stall warning system inlet and noting the warning horn sounds.

- k. Fuel Quantity Check
 - l. Fuel Selector Select Fullest Tank
 - m. Flaps.....100%, Check Light ON
 - n. Oil Annunciator On
 - o. Bat 1 and 2 Master Switches..... OFF
 - p. Alternate Static Source.....NORMAL
 - q. Circuit Breakers IN
 - r. Fire Extinguisher Charged and Available
 - s. Emergency Egress HammerAvailable
 - t. APS HandlePin Removed
2. Left Fuselage
 - a. Door Lock Unlock
 - b. COM 1 Antenna (top)Condition and Attachment
 - c. Transponder Antenna (underside) ...Condition and Attachment
 - d. Wing/Fuselage Fairing..... Check
 - e. COM 2 Antenna (underside)Condition and Attachment

(Continued on following page)

- f. Baggage Door Closed and Secure
 - g. Static Button Check for Blockage
 - h. Parachute Cover Sealed and Secure
3. Empennage
- a. Tiedown Rope Remove
 - b. Horizontal and Vertical Stabilizers Condition

• Note •

Verify tape covering the forward and aft inspection holes located on outboard ends of horizontal stabilizer is installed and securely attached.

- c. Elevator and Tab Condition and Movement
 - d. Rudder Freedom of Movement
 - e. Rudder Trim Tab Condition and Security
 - f. Attachment hinges, bolts and cotter pins Secure
4. Right Fuselage
- a. Static Button Check for Blockage
 - b. Wing/Fuselage Fairings Check
 - c. Door Lock Unlock
5. Right Wing Trailing Edge
- a. Flap and Rub Strips (if installed) Condition and Security
 - b. Aileron and Tab Condition and Movement
 - c. Aileron Gap Seal Security
 - d. Hinges, actuation arm, bolts, and cotter pins Secure
6. Right Wing Tip
- a. Tip Attachment
 - b. Strobe, Nav Light and Lens Condition and Security
 - c. Fuel Vent (underside) Unobstructed
7. Right Wing Forward and Main Gear
- a. Leading Edge and Stall Strips Condition
 - b. Fuel Cap Check Quantity and Secure
 - c. Fuel Drains (2 underside) Drain and Sample
 - d. Wheel Fairings Security, Accumulation of Debris

- e. TireCondition, Inflation, and Wear

• Caution •

Clean and inspect temperature indicator installed to piston housing. If indicator center is black, the brake assembly has been overheated. The brake linings must be inspected and O-rings replaced.

- f. Wheel and Brakes Fluid Leaks, Evidence of Overheating, General Condition, and Security.
 - g. Chocks and Tiedown Ropes.....Remove
 - h. Cabin Air Vent.....Unobstructed
8. Nose, Right Side
- a. Vortex Generator Condition
 - b. Cowling.....Attachments Secure
 - c. Exhaust Pipe Condition, Security, and Clearance
 - d. Gas-collator (underside)..... Drain for 3 seconds, Sample
9. Nose gear, Propeller, and Spinner

• WARNING •

Keep clear of propeller rotation plane. Do not allow others to approach propeller.

- a. Tow BarRemove and Stow
 - b. Strut.....Condition
 - c. Wheel Fairing Security, Accumulation of Debris
 - d. Wheel and TireCondition, Inflation, and Wear
 - e. Propeller..... Condition (indentations, nicks, etc.)
 - f. Spinner Condition, Security, and Oil Leaks
 - g. Air InletsUnobstructed
 - h. Alternator.....Condition
10. Nose, Left Side
- a. Landing Light.....Condition
 - b. Engine Oil Check 6-8 quarts, Leaks, Cap & Door Secure
 - c. Cowling.....Attachments Secure

(Continued on following page)

- d. External PowerDoor Secure
- e. Vortex GeneratorCondition
- f. Exhaust Pipe(s)Condition, Security, and Clearance

11. Left Main Gear and Forward Wing

- a. Wheel fairings Security, Accumulation of Debris
- b. TireCondition, Inflation, and Wear

• **Caution** •

Clean and inspect temperature indicator installed to piston housing. If indicator center is black, the brake assembly has been overheated. The brake linings must be inspected and O-rings replaced.

- c. Wheel and Brakes Fluid Leaks, Evidence of Overheating, General Condition, and Security.
- d. Chocks and Tiedown Ropes.....Remove
- e. Fuel Drains (2 underside) Drain and Sample
- f. Cabin Air Vent..... Unobstructed
- g. Fuel Cap Check Quantity and Secure
- h. Leading Edge and Stall StripsCondition

12. Left Wing Tip

- a. Fuel Vent (underside) Unobstructed
- b. Pitot Mast (underside) Cover Removed, Tube Clear
- c. Strobe, Nav Light and LensCondition and Security
- d. TipAttachment

13. Left Wing Trailing Edge

- a. Flap And Rub Strips (If installed).....Condition and Security
- b. Aileron Freedom of movement
- c. Aileron Gap SealSecurity
- d. Hinges, actuation arm, bolts, and cotter pins Secure

Before Starting Engine

1. Preflight InspectionCOMPLETED

• WARNING •

Ensure that the airplane is properly loaded and within the AFM's weight and balance limitations prior to takeoff.

2. Weight and BalanceVerify within limits
 3. Emergency Equipment ON BOARD
 4. Passengers BRIEFED

• Note •

Ensure all the passengers have been fully briefed on smoking, the use of the seat belts, doors, emergency exits, egress hammer, and APS.

Verify APS handle safety pin is removed.

5. Seats, Seat Belts, and HarnessesADJUST & SECURE

• Caution •

Crew seats must be locked in position and control handles fully down before flight. Ensure seat belt harnesses are not twisted.

Starting Engine

If the engine is warm, no priming is required. For the first start of the day and in cold conditions, prime will be necessary.

Weak intermittent firing followed by puffs of black smoke from the exhaust stack indicates over-priming or flooding. Excess fuel can be cleared from the combustion chambers by the following procedure:

- Turn fuel pump off.
- Allow fuel to drain from intake tubes.
- Set the mixture control full lean and the power lever full open.
- Crank the engine through several revolutions with the starter.
- When engine starts, release ignition switch, retard power lever, and slowly advance the mixture control to FULL RICH position.

If the engine is under-primed, especially with a cold soaked engine, it will not fire, and additional priming will be necessary. As soon as the cylinders begin to fire, open the power lever slightly to keep it running. Refer to Cold Weather Operation in this section or additional information regarding cold weather operations.

• WARNING •

If airplane will be started using external power, keep all personnel and power unit cables well clear of the propeller rotation plane.

• Caution •

Alternators should be left OFF during engine starting to avoid high electrical loads.

After starting, if the oil gage does not begin to show pressure within 30 seconds in warm weather and about 60 seconds in very cold weather, shut down engine and investigate cause. Lack of oil pressure indicates loss of lubrication, which can cause severe engine damage.

1. External Power (If applicable) CONNECT
2. Brakes HOLD
3. Bat Master Switches ON (Check Volts)
4. Strobe Lights ON
5. Mixture FULL RICH

6. Power Lever FULL FORWARD
7. Fuel Pump PRIME, then BOOST

• Note •

On first start of the day, especially under cool ambient conditions, holding Fuel Pump switch to PRIME for 2 seconds will improve starting.

8. Propeller Area CLEAR
9. Power Lever OPEN ¼ INCH
10. Ignition Switch START (Release after engine starts)

• Caution •

Limit cranking to intervals of 20 seconds with a 20 second cooling period between cranks. This will improve battery and contactor life.

11. Power Lever RETARD (to maintain 1000 RPM)
12. Oil Pressure CHECK
13. Alt Master Switches ON
14. Avionics Power Switch ON
15. Engine Parameters MONITOR
16. External Power (If applicable) DISCONNECT
17. Amp Meter/Indication CHECK

Before Taxiing

1. Flaps UP (0%)
2. Radios/Avionics..... AS REQUIRED
3. Cabin Heat/Defrost AS REQUIRED
4. Fuel SelectorSWITCH TANK

Taxiing

When taxiing, directional control is accomplished with rudder deflection and intermittent braking (toe taps) as necessary. Use only as much power as is necessary to achieve forward movement. Deceleration or taxi speed control using brakes but without a reduction in power will result in increased brake temperature. Taxi over loose gravel at low engine speed to avoid damage to the propeller tips.

• WARNING •

Maximum continuous engine speed for taxiing is 1000 RPM on flat, smooth, hard surfaces. Power settings slightly above 1000 RPM are permissible to start motion, for turf, soft surfaces, and on inclines. Use minimum power to maintain taxi speed.

If the 1000 RPM taxi power limit and proper braking procedures are not observed, the brake system may overheat and result in brake damage or brake fire.

1. Parking Brake.....DISENGAGE
2. Brakes CHECK
3. HSI Orientation CHECK
4. Attitude Gyro CHECK
5. Turn Coordinator CHECK

Before Takeoff

During cold weather operations, the engine should be properly warmed up before takeoff. In most cases this is accomplished when the oil temperature has reached at least 100°F (38°C). In warm or hot weather, precautions should be taken to avoid overheating during prolonged ground engine operation. Additionally, long periods of idling may cause fouled spark plugs.

• WARNING •

Do not takeoff with frost, ice, snow, or other contamination on the fuselage, wing, stabilizers, and control surfaces.

1. Doors LATCHED
2. APS Handle Verify Pin Removed
3. Seat Belts and Shoulder Harness..... SECURE
4. Air Conditioner AS DESIRED

• Note •

If Air Conditioner is ON for takeoff roll, see Section 5, Performance for takeoff distance change. No takeoff distance change is necessary if system remains OFF for takeoff roll.

5. Fuel Quantity CONFIRM
6. Fuel Selector..... FULLEST TANK
7. Fuel Pump BOOST
8. Mixture AS REQUIRED
9. Flaps SET 50% & CHECK
10. Transponder SET
11. Autopilot..... CHECK
12. Navigation Radios/GPS SET for Takeoff
13. Cabin Heat/Defrost AS REQUIRED
14. Brakes..... HOLD
15. Power Lever 1700 RPM
16. Alternator CHECK
 - a. Pitot Heat..... ON

(Continued on following page)

- b. Navigation Lights ON
- c. Landing Light ON
- d. Annunciator Lights CHECK
 - Verify both ALT 1 and ALT 2 caution lights out and positive amps indication for each alternator.

17. Voltage CHECK

18. Pitot Heat AS REQUIRED

• Note •

Pitot Heat should be turned ON for flight into IMC, flight into visible moisture, or whenever ambient temperatures are 41° F (5° C) or less.

19. Navigation Lights AS REQUIRED

20. Landing Light AS REQUIRED

21. Magnetos CHECK Left and Right

- a. Ignition Switch R, note RPM, then BOTH
- b. Ignition Switch L, note RPM, then BOTH

• Note •

RPM drop must not exceed 150 RPM for either magneto. RPM differential must not exceed 75 RPM between magnetos. If there is a doubt concerning operation of the ignition system, RPM checks at higher engine speeds will usually confirm whether a deficiency exists.

An absence of RPM drop may indicate faulty grounding of one side of the ignition system or magneto timing set in advance of the specified setting.

22. Engine Parameters CHECK

23. Power Lever 1000 RPM

24. Flight Instruments, HSI, and Altimeter CHECK & SET

25. Flight Controls FREE & CORRECT

26. Trim SET Takeoff

27. Autopilot DISCONNECT

Maximum Power Fuel Flow

Serials w/ Integrated System software load 0764-01: Leaning for Takeoff and Maximum Climb is accomplished at full throttle by leaning the mixture from full rich to the target fuel flow for the given pressure altitude per the table below.

Serials w/ Integrated System software load 0764-02 and later: Target fuel flow is indicated by the top of a dynamically calculated green arc displayed on the fuel gage. Target fuel flow should be maintained at the top of this arc by use of the mixture lever.

The fuel flow values in the table below were demonstrated to obtain the takeoff and climb performance presented in Section 5.

Pressure Altitude	Target Fuel Flow	Pressure Altitude	Target Fuel Flow	Pressure Altitude	Target Fuel Flow
0	27.1	7000	21.4	14,000	17.5
1000	26.2	8000	20.5	15,000	16.9
2000	25.1	9000	19.9	16,000	16.7
3000	24.3	10,000	19.5	17,000	16.2
4000	23.6	11,000	18.8	17,500	16.1
5000	22.8	12,000	18.4		
6000	22.1	13,000	17.9		

• Note •

Excessively rich mixture will occur if the Mixture control is set to FULL RICH above 7500 feet pressure altitude.

Takeoff

Power Check: Check full-throttle engine operation early in takeoff run. The engine should run smoothly and turn approximately 2700 RPM. All engine parameters should read in the green. Discontinue takeoff at any sign of rough operation or sluggish acceleration. Make a thorough full-throttle static run-up before attempting another takeoff.

For takeoff over a gravel surface, advance Power Lever slowly. This allows the airplane to start rolling before high RPM is developed, and gravel will be blown behind the propeller rather than pulled into it.

Flap Settings: Normal and short field takeoffs are accomplished with flaps set at 50%. Takeoffs using 0% are permissible, however, no performance data is available for takeoffs in the flaps up configuration. Takeoffs with 100% flaps are not approved.

Soft or rough field takeoffs are performed with 50% flaps by lifting the airplane off the ground as soon as practical in a tail-low attitude. If no obstacles are ahead, the airplane should be leveled off immediately to accelerate to a higher climb speed.

Takeoffs into strong crosswinds are normally performed with the flaps set at 50% to minimize the drift angle immediately after takeoff. With the ailerons fully deflected into the wind, accelerate the airplane to a speed slightly higher than normal while decreasing the aileron deflection as speed increases then - with authority - rotate to prevent possibly settling back to the runway while drifting. When clear of the ground, make a coordinated turn into the wind to correct for drift.

• Note •

Fuel BOOST should be left ON during takeoff and for climb as required for vapor suppression with hot or warm fuel.

Normal Takeoff

1. BrakesRELEASE (Steer with Rudder Only)
2. Power LeverFULL FORWARD
3. Engine Parameters CHECK
4. Elevator Control ROTATE Smoothly at 70-73 KIAS
5. At 80 KIAS, Flaps..... UP

Short Field Takeoff

1. Flaps 50%
2. Brakes HOLD
3. Power Lever FULL FORWARD
4. Mixture SET
5. Engine Parameters CHECK
6. Brakes..... RELEASE (Steer with Rudder Only)
7. Elevator Control ROTATE Smoothly at 70 KIAS
8. Airspeed at Obstacle 78 KIAS

Climb

Normal climbs are performed flaps UP (0%) and full power at speeds 5 to 10 knots higher than best rate-of-climb speeds. These higher speeds give the best combination of performance, visibility and engine cooling.

For maximum rate of climb, use the best rate-of-climb speeds shown in the rate-of-climb chart in Section 5. If an obstruction dictates the use of a steep climb angle, the best angle-of-climb speed should be used. Climbs at speeds lower than the best rate-of-climb speed should be of short duration to avoid engine-cooling problems.

1. Climb Power..... SET
2. Flaps Verify UP
3. Mixture LEAN as required for altitude
4. Engine Parameters CHECK
5. Fuel Pump BOOST

• Note •

The fuel pump is used for vapor suppression during climb. It is also recommended that the fuel pump be left on after leveling off for 30 minutes following a climb and anytime fuel flow or EGT anomalies occur.

Cruise

Normal cruising is performed between 55% and 85% power. The engine power setting and corresponding fuel consumption for various altitudes and temperatures can be determined by using the cruise data in Section 5.

The selection of cruise altitude is made based on the most favorable wind conditions and the desired power settings. These significant factors should be considered on every trip to reduce fuel consumption.

• Note •

For engine break-in, cruise at a minimum of 75% power until the engine has been operated for at least 25 hours or until oil consumption has stabilized. Operation at this higher power will ensure proper seating of the rings, is applicable to new engines, and engines in service following cylinder replacement or top overhaul of one or more cylinders.

1. Fuel Pump.....OFF

• Note •

The Fuel Pump may be used for vapor suppression during cruise.

2. Cruise Power.....SET
3. Mixture LEAN as required
4. Engine Parameters MONITOR

• Note •

Fuel BOOST must be used for switching from one tank to another. Failures to activate the Fuel Pump before transfer could result in delayed restart if the engine should quit due to fuel starvation.

5. Fuel Flow and Balance..... MONITOR

Cruise Leaning

Exhaust gas temperature (EGT) may be used as an aid for mixture leaning in cruise flight. For “Best Power” use **75% power or less**. For “Best Economy” use **65% power or less**. To adjust the mixture, lean to establish the peak EGT as a reference point and then adjust the mixture by the desired increment based on the following table:

Mixture Description	Exhaust Gas Temperature
Best Power	75°F Rich Of Peak EGT
Best Economy	50°F Lean Of Peak EGT

Under some conditions, engine roughness may occur while operating at best economy. If this occurs, enrich mixture as required to smooth engine operation. Any change in altitude or Power Lever position will require a recheck of EGT indication.

Descent

1. Altimeter..... SET
2. Cabin Heat/Defrost AS REQUIRED
3. Landing LightON
4. Fuel System..... CHECK
5. Mixture AS REQUIRED
6. Brake Pressure CHECK

Before Landing

1. Seat Belt and Shoulder Harness SECURE
2. Fuel Pump BOOST
3. Mixture AS REQUIRED
4. Flaps AS REQUIRED
5. Autopilot AS REQUIRED

Landing

• Caution •

Landings should be made with full flaps. Landings with less than full flaps are recommended only if the flaps fail to deploy or to extend the aircraft's glide distance due to engine malfunction. Landings with flaps at 50% or 0%; power should be used to achieve a normal glide path and low descent rate. Flare should be minimized.

Normal Landing

Normal landings are made with full flaps with power on or off. Surface winds and air turbulence are usually the primary factors in determining the most comfortable approach speeds.

Actual touchdown should be made with power off and on the main wheels first to reduce the landing speed and subsequent need for braking. Gently lower the nose wheel to the runway after airplane speed has diminished. This is especially important for rough or soft field landings.

Short Field Landing

For a short field landing in smooth air conditions, make an approach at 77 KIAS with full flaps using enough power to control the glide path (slightly higher approach speeds should be used under turbulent air conditions). After all approach obstacles are cleared, progressively reduce power to reach idle just before touchdown and maintain the approach speed by lowering the nose of the airplane. Touchdown should be made power-off and on the main wheels first. Immediately after touchdown, lower the nose wheel and apply braking as required. For maximum brake effectiveness, retract the flaps, hold the control yoke full back, and apply maximum brake pressure without skidding.

Crosswind Landing

Normal crosswind landings are made with full flaps. Avoid prolonged slips. After touchdown, hold a straight course with rudder and brakes as required.

The maximum allowable crosswind velocity is dependent upon pilot capability as well as aircraft limitations. Operation in direct crosswinds of 20 knots has been demonstrated.

Balked Landing/Go-Around

In a balked landing (go around) climb, disengage autopilot, apply full power, then reduce the flap setting to 50%. If obstacles must be cleared during the go around, climb at 75-80 KIAS with 50% flaps. After clearing any obstacles, retract the flaps and accelerate to the normal flaps up climb speed.

1. Autopilot.....DISENGAGE
2. Power Lever FULL FORWARD
3. Flaps 50%
4. Airspeed.....75-80 KIAS

After clear of obstacles:

5. Flaps UP

After Landing

1. Power Lever 1000 RPM
2. Fuel Pump OFF
3. Flaps UP
4. TransponderSTBY
5. Lights AS REQUIRED
6. Pitot Heat OFF

• Note •

As the airplane slows the rudder becomes less effective and taxiing is accomplished using differential braking.

Shutdown

1. Fuel Pump (if used)OFF
2. Throttle..... IDLE

• Caution •

Note that the engine hesitates as the switch cycles through the “OFF” position. If the engine does not hesitate, one or both magnetos are not grounded. Prominently mark the propeller as being “Hot,” and contact maintenance personnel immediately.

3. Ignition Switch.....CYCLE
4. Mixture CUTOFF
5. All Switches.....OFF
6. MagnetosOFF
7. ELT..... TRANSMIT LIGHT OUT

• Note •

After a hard landing, the ELT may activate. If this is suspected, press the RESET button.

8. Chocks, Tie-downs, Pitot Covers AS REQUIRED

Stalls

Aircraft stall characteristics are conventional. Power-off stalls may be accompanied by a slight nose bobbing if full aft stick is held. Power-on stalls are marked by a high sink rate at full aft stick. Power-off stall speeds at maximum weight for both forward and aft CG positions are presented in Section 5 - Performance Data.

When practicing stalls at altitude, as the airspeed is slowly reduced, you will notice a slight airframe buffet, hear the stall speed warning horn sound between 5 and 10 knots before the stall, and see the Crew Alerting System display a STALL Warning annunciation. Normally, the stall is marked by a gentle nose drop and the wings can easily be held level or in the bank with coordinated use of the ailerons and rudder. Upon stall warning in flight, recovery is accomplished by immediately reducing back pressure to maintain safe airspeed, adding power if necessary and rolling wings level with coordinated use of the controls.

• WARNING •

Extreme care must be taken to avoid uncoordinated, accelerated or abused control inputs when close to the stall, especially when close to the ground.

Environmental Considerations

Cold Weather Operation

• **Caution** •

An engine that has been superficially warmed, may start and appear to run satisfactorily, but can be damaged from lack of lubrication due to the congealed oil blocking proper oil flow through the engine. The amount of damage will vary and may not become evident for many hours. However, the engine may be severely damaged and may fail shortly following application of high power. Proper procedures require thorough application of preheat to all parts of the engine. Hot air must be applied directly to the oil sump and external oil lines as well as the cylinders, air intake and oil cooler. Because excessively hot air can damage non-metallic components such as composite parts, seals, hoses, and drives belts, do not attempt to hasten the preheat process.

Starting

If the engine has been cold soaked, it is recommended that the propeller be pulled through by hand several times to break loose or limber the oil. This procedure will reduce power draw on the battery if a battery start is made.

When the engine has been exposed to temperatures at or below 20°F (-7°C) for a period of two hours or more, the use of an external pre-heater and external power is recommended. Failure to properly preheat a cold-soaked engine may result in oil congealing within the engine, oil hoses, and oil cooler with subsequent loss of oil flow, possible internal damage to the engine, and subsequent engine failure.

If the engine does not start during the first few attempts, or if engine firing diminishes in strength, the spark plugs have probably frosted over. Preheat must be used before another start is attempted.

1. Ignition Switch.....OFF

• WARNING •

Use caution when pulling the propeller through by hand. Make sure ignition switch is OFF, keys are out of ignition, and then act as if the engine will start.

2. Propeller Hand TURN several rotations
3. External Power (If applicable) CONNECT
4. Brakes HOLD
5. Bat Master Switches ON (check voltage)
6. Mixture FULL RICH
7. Power lever FULL FORWARD
8. Fuel Pump PRIME, then BOOST

• Note •

In temperatures down to 20°F, hold Fuel Pump switch to PRIME for 15 seconds prior to starting.

9. Propeller Area CLEAR
10. Power Lever OPEN ¼ INCH
11. Ignition Switch..... START (Release after engine starts)

• Caution •

Limit cranking to intervals of 20 seconds with a 20 second cooling period between cranks.

12. Power Lever RETARD (to maintain 1000 RPM)
13. Oil Pressure CHECK
14. Alt Master Switches ON
15. Avionics Power Switch ON
16. Engine Parameters MONITOR
17. External Power (If applicable) DISCONNECT
18. Amp Meter/Indication CHECK
19. Strobe Lights..... ON

Hot Weather Operation

Avoid prolonged engine operation on the ground. Fuel BOOST must be ON for engine start and takeoff, and should be ON during climb for vapor suppression which could occur under hot ambient conditions or after extended idle.

Ground Operation of Air Conditioning System (Optional)

• Note •

To facilitate faster cabin cooling, prior to engine start leave the cabin doors open for a short time to allow hot air to escape cabin.

1. Control Panel SELECT Desired Mode and Temperature
2. Voltage MONITOR

• Note •

Decrease electrical load if battery discharge is noted.

3. Annunciator Lights CHECK
 - a. Verify ALT 1 caution light out and positive amps indication.
4. Engine Parameters CHECK

Noise Characteristics/Abatement

The certificated noise levels for the aircraft established in accordance with FAR 36 Appendix G are:

Configuration	Actual	Maximum Allowable
Hartzel 3-blade Propeller PHC-J3YF-1RF/F7694	83.65 dB(A)	88.00 dB(A)
Hartzel 3-blade Propeller PHC-J3YF-1RF/F7693DF	84.81 dB(A)	88.00 dB(A)
McCauley 3-blade Propeller D3A34C443/78CYA-0	83.15 dB(A)	88.00 dB(A)
MT 3-blade Propeller MTV-9-D/198-52	84.80 dB(A)	88.00 dB(A)

No determination has been made by the Federal Aviation Administration that the noise levels of this airplane are or should be acceptable or unacceptable for operation at, into, or out of, any airport. The above noise levels were established at 3400 pounds takeoff weight and 2700 RPM.

Recently, increased emphasis on improving environmental quality requires all pilots to minimize the effect of airplane noise on the public. The following suggested procedures minimize environmental noise when operating the aircraft.

• Note •

Do not follow these noise abatement procedures where they conflict with Air Traffic Control clearances or instructions, weather considerations, or wherever they would reduce safety.

1. When operating VFR over noise-sensitive areas, such as outdoor events, parks, and recreational areas, fly not less than 2000 feet above the surface even though flight at a lower level may be allowed.
2. For departure from or approach to an airport, avoid prolonged flight at low altitude near noise-sensitive areas.

Fuel Conservation

Minimum fuel use at cruise will be achieved using the best economy power setting described under cruise.

Intentionally Left Blank

Section 5

Performance Data

Table of Contents

Introduction	3
Associated Conditions Affecting Performance.....	3
Demonstrated Operating Temperature	3
Airspeed Calibration - Normal Static Source.....	4
Airspeed Calibration - Alternate Static Source	5
Altitude Correction Normal Static Source: Primary Flight Display.....	6
Altitude Correction Normal Static Source: Standby Altimeter	7
Altitude Correction Alternate Static Source: Primary Flight Display...	8
Altitude Correction Alternate Static Source: Standby Altimeter	9
Temperature Conversion	10
Outside Air Temperature for ISA Condition.....	11
Stall Speeds	12
Wind Components	13
Takeoff Distance	14
Takeoff Distance - 3400 LB	15
Takeoff Distance - 2900 LB	16
Takeoff Climb Gradient.....	17
Takeoff Rate of Climb	18
Enroute Climb Gradient	19
Enroute Rate of Climb	20
Enroute Rate of Climb Vs Density Altitude.....	21
Time, Fuel and Distance to Climb	22
Cruise Performance	23
Range / Endurance Profile.....	25
Balked Landing Climb Gradient.....	27
Balked Landing Rate of Climb	28
Landing Distance	29
Landing Distance	30

Intentionally Left Blank

Introduction

Performance data in this section are presented for operational planning so that you will know what performance to expect from the airplane under various ambient and field conditions. Performance data are presented for takeoff, climb, and cruise (including range & endurance).

Aircraft with optional Air Conditioning System; Brake Horsepower is reduced by approximately 6 BHP.

Associated Conditions Affecting Performance

Computed performance data in this section are based upon data derived from actual flight testing with the airplane and engine in good condition and using average piloting techniques. Unless specifically noted in the “Conditions” notes presented with each table, ambient conditions are for a standard day (refer to Section 1). Flap position as well as power setting technique is similarly noted with each table.

The charts in this section provide data for ambient temperatures from -4°F (-20°C) to 104°F (40°C). If ambient temperature is below the chart value, use the lowest temperature shown to compute performance. This will result in more conservative performance calculations. If ambient temperature is above the chart value, use extreme caution as performance degrades rapidly at higher temperatures.

Demonstrated Operating Temperature

Satisfactory engine cooling has been demonstrated for this airplane with an outside air temperature 23°C above standard. The value given is not considered an operating limitation. Reference should be made to Section 2 for engine operating limitations.

Airspeed Calibration - Normal Static Source

Conditions:

- Power for level flight or maximum continuous, whichever is less.

• Note •

Indicated airspeed values assume zero instrument error.

KIAS	KCAS		
	Flaps 0%	Flaps 50%	Flaps 100%
60	57	56	57
70	68	68	70
80	79	80	80
90	89	91	89
100	100	101	99
110	111	111	111
120	121	121	
130	132		
140	142		
150	152		
160	163		
170	173		
180	183		
190	193		
200	204		

Airspeed Calibration - Alternate Static Source

Conditions:

- Power for level flight or maximum continuous, whichever is less.
- Heater, Defroster & Vents ON

• Note •

Indicated airspeed values assume zero instrument error.

KIAS	KCAS		
	Flaps 0%	Flaps 50%	Flaps 100%
60	61	58	54
70	68	66	63
80	77	74	72
90	85	83	82
100	94	92	92
110	103	102	101
120	112	112	
130	121	122	
140	131		
150	141		
160	150		
170	160		
180	170		
190	179		
200	189		
210	198		

Altitude Correction

Normal Static Source: Primary Flight Display

Conditions:

- Power for level flight or maximum continuous, whichever is less.
- 3400 LB

• Note •

Add correction to desired altitude to obtain indicated altitude to fly.

Indicated airspeed values assume zero instrument error.

KIAS: Knots Indicated Airspeed.

Flaps	Density Alt	CORRECTION TO BE ADDED - FEET									
		Normal Static Source - KIAS									
		60	70	80	90	100	120	140	160	180	200
0%	S.L		0	0	0	0	0	0	0	0	0
	5000		0	0	0	0	0	0	0	0	0
	10000		0	0	0	0	0	0	0	0	0
	15000		0	0	0	0	0	0	0	0	0
50%	S.L		-1	-6	-10	-11	-3				
	5000		-2	-7	-12	-13	-4				
	10000		-2	-9	-14	-15	-4				
100%	S.L	0	-11	-10	-1	6					
	5000	0	-13	-12	-1	7					
	10000	0	-15	-14	-1	8					

Altitude Correction

Normal Static Source: Standby Altimeter

Conditions:

- Power for level flight or maximum continuous, whichever is less.
- 3400 LB

• Note •

Add correction to desired altitude to obtain indicated altitude to fly.

Indicated airspeed values assume zero instrument error.

KIAS: Knots Indicated Airspeed.

Flaps	Density Alt	CORRECTION TO BE ADDED - FEET									
		Normal Static Source - KIAS									
		60	70	80	90	100	120	140	160	180	200
0%	S.L		12	9	5	0	-11	-24	-37	-50	-60
	5000		14	11	6	0	-13	-28	-43	-57	-69
	10000		17	12	7	0	-15	-33	-50	-67	-81
	15000		20	15	8	0	-18	-38	-59	-79	-95
50%	S.L		11	3	-5	-11	-14				
	5000		13	3	-6	-13	-17				
	10000		15	4	-7	-15	-20				
100%	S.L	15	1	-1	4	6					
	5000	17	1	-1	5	7					
	10000	20	1	-1	6	8					

Altitude Correction

Alternate Static Source: Primary Flight Display

Conditions:

- Power for level flight or maximum continuous, whichever is less.
- Heater, Defroster, & Vents ON

• Note •

Add correction to desired altitude to obtain indicated altitude to fly.

Indicated airspeed values assume zero instrument error.

KIAS: Knots Indicated Airspeed.

Flaps	Density Alt	CORRECTION TO BE ADDED - FEET									
		Alternate Static Source - KIAS									
		60	70	80	90	100	120	140	160	180	200
0%	S.L		-3	16	35	56	98	139	178	218	265
	5000		-3	18	41	65	114	161	207	253	307
	10000		-3	21	48	76	133	188	241	296	358
	15000		-4	25	56	89	156	220	283	347	420
50%	S.L		13	31	50	69	102				
	5000		15	36	58	80	119				
	10000		17	42	68	94	139				
100%	S.L	14	30	44	57	71					
	5000	16	35	51	66	82					
	10000	18	40	60	77	96					

Altitude Correction

Alternate Static Source: Standby Altimeter

Conditions:

- Power for level flight or maximum continuous, whichever is less.
- Heater, Defroster, & Vents..... ON

• Note •

Add correction to desired altitude to obtain indicated altitude to fly.

Indicated airspeed values assume zero instrument error.

KIAS: Knots Indicated Airspeed.

Flaps	Density Alt	CORRECTION TO BE ADDED - FEET									
		Alternate Static Source - KIAS									
		60	70	80	90	100	120	140	160	180	200
0%	S.L		10	25	40	56	87	114	141	169	205
	5000		11	29	47	65	100	133	163	196	238
	10000		13	34	55	76	117	155	191	229	277
	15000		16	39	64	89	138	182	224	268	325
50%	S.L		25	40	55	69	91				
	5000		29	46	64	81	106				
	10000		34	54	75	94	123				
100%	S.L	28	42	53	62	71					
	5000	33	49	62	72	83					
	10000	38	57	72	84	96					

Temperature Conversion

To convert from Celsius (°C) to Fahrenheit (°F), find, in the shaded columns, the number representing the temperature value (°C) to be converted. The equivalent Fahrenheit temperature is read to the right.

► EXAMPLE: 38°C = 100°F.

To convert from Fahrenheit (°F) to Celsius (°C), find in the shaded columns area, the number representing the temperature value (°F) to be converted. The equivalent Celsius temperature is read to the left.

► EXAMPLE: 38°F = 3°C.

Temp to Convert °C or °F			Temp to Convert °C or °F			Temp to Convert °C or °F		
°C	◀ ▶	°F	°C	◀ ▶	°F	°C	◀ ▶	°F
-50	-58	-72	-17	2	36	17	62	144
-49	-56	-69	-16	4	39	18	64	147
-48	-54	-65	-14	6	43	19	66	151
-47	-52	-62	-13	8	46	20	68	154
-46	-50	-58	-12	10	50	21	70	158
-44	-48	-54	-11	12	54	22	72	162
-43	-46	-51	-10	14	57	23	74	165
-42	-44	-47	-9	16	61	24	76	169
-41	-42	-44	-8	18	64	26	78	172
-40	-40	-40	-7	20	68	27	80	176
-39	-38	-36	-6	22	72	28	82	180
-38	-36	-33	-4	24	75	29	84	183
-37	-34	-29	-3	26	79	30	86	187
-36	-32	-26	-2	28	82	31	88	190
-34	-30	-22	-1	30	86	32	90	194
-33	-28	-18	0	32	90	33	92	198
-32	-26	-15	1	34	93	34	94	201
-31	-24	-11	2	36	97	36	96	205
-30	-22	-8	3	38	100	37	98	208
-29	-20	-4	4	40	104	38	100	212
-28	-18	0	6	42	108	39	102	216
-27	-16	3	7	44	111	40	104	219
-26	-14	7	8	46	115	41	106	223
-24	-12	10	9	48	118	42	108	226
-23	-10	14	10	50	122	43	110	230
-22	-8	18	11	52	126	44	112	234
-21	-6	21	12	54	129	46	114	237
-20	-4	25	13	56	133	47	116	241
-19	-2	28	14	58	136	48	118	244
-18	0	32	16	60	140	49	120	248

Outside Air Temperature for ISA Condition

Press Alt Feet	ISA-40°C		ISA-20°C		ISA		ISA+10°C		ISA+20°C	
	°C	°F	°C	°F	°C	°F	°C	°F	°C	°F
SL	-25	-13	-5	23	15	59	25	77	35	95
1000	-27	-18	-7	18	13	54	23	72	33	90
2000	-29	-20	-9	16	11	52	21	70	31	88
3000	-31	-24	-11	12	9	48	19	66	29	84
4000	-33	-27	-13	9	7	45	17	63	27	81
5000	-35	-31	-15	5	5	41	15	59	25	77
6000	-37	-34	-17	2	3	38	13	56	23	74
7000	-39	-38	-19	-2	1	34	11	52	21	70
8000	-41	-42	-21	-6	-1	30	10	48	20	66
9000	-43	-45	-23	-9	-3	27	7	45	17	63
10000	-45	-49	-25	-13	-5	23	5	41	15	59
11000	-47	-52	-27	-16	-7	20	3	38	13	56
12000	-49	-56	-29	-20	-9	16	1	34	11	52
13000	-51	-59	-31	-23	-11	13	-1	31	9	49
14000	-53	-63	-33	-27	-13	9	-3	27	7	45
15000	-55	-67	-35	-31	-15	6	-5	23	5	41
16000	-57	-71	-37	-34	-17	2	-7	20	3	38
17000	-59	-75	-39	-38	-19	-2	-9	16	1	34
17500	-60	-76	-40	-40	-20	-3	-10	14	0	32

Stall Speeds

Conditions:

- Weight 3400 LB
- CG Noted
- Power Idle
- Bank Angle Noted

• Note •

Altitude loss during wings level stall may be 250 feet or more.

KIAS values may not be accurate at stall.

Weight LB	Bank Angle Deg	STALL SPEEDS					
		Flaps 0% Full Up		Flaps 50%		Flaps 100% Full Down	
		KIAS	KCAS	KIAS	KCAS	KIAS	KCAS
3400 Most FWD CG	0	73	70	66	64	62	60
	15	74	71	67	65	64	61
	30	76	75	71	69	66	64
	45	83	83	77	76	72	71
	60	99	99	90	90	84	84
3400 Most AFT CG	0	72	69	65	63	60	58
	15	73	70	66	64	61	59
	30	76	74	69	67	63	62
	45	82	82	76	75	69	69
	60	98	98	89	89	82	82

Wind Components

Example:

- Runway Heading..... 10°
- Wind Direction..... 60°
- Wind Velocity..... 15 Knots

• Note •

The max demonstrated crosswind is 20 knots. Value not considered limiting.

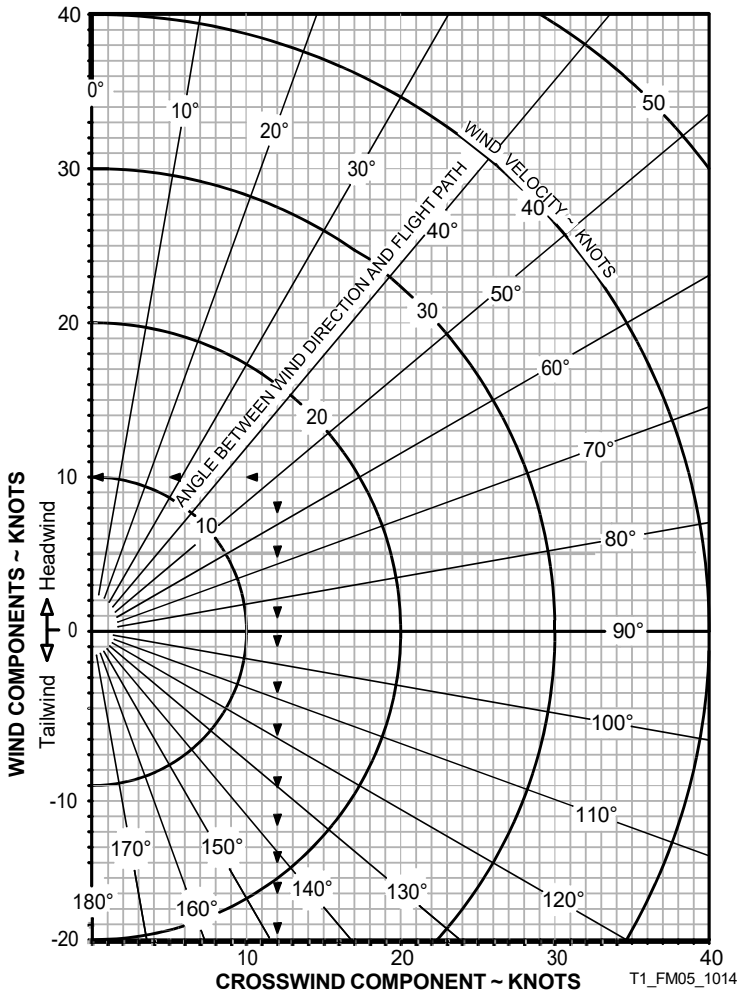

Takeoff Distance

Conditions:

- Winds.....Zero
- Runway.....Dry, Level, Paved
- Flaps.....50%
- Air Conditioner.....OFF
- Power:
 - Throttle.....Full Open
 - Mixture.....Set per Placard
Set prior to brake release for short field takeoff.

The following factors are to be applied to the computed takeoff distance for the noted condition:

- Headwind - Subtract 10% from computed distance for each 12 knots headwind.
- Tailwind - Add 10% for each 2 knots tailwind up to 10 knots.
- Grass Runway, Dry - Add 20% to ground roll distance.
- Grass Runway, Wet - Add 30% to ground roll distance.
- Sloped Runway - Increase table distances by 22% of the ground roll distance at Sea Level, 30% of the ground roll distance at 5000 ft, 43% of the ground roll distance at 10,000 ft for each 1% of upslope. Decrease table distances by 7% of the ground roll distance at Sea Level, 10% of the ground roll distance at 5000 ft, and 14% of the ground roll distance at 10,000 ft for each 1% of downslope.

• Caution •

The above corrections for runway slope are required to be included herein. These corrections should be used with caution since published runway slope data is usually the net slope from one end of the runway to the other. Many runways will have portions of their length at greater or lesser slopes than the published slope, lengthening (or shortening) takeoff ground roll estimated from the table.

- If brakes are not held while applying power, distances apply from point where full throttle and mixture setting is complete.
- For operation in outside air temperatures colder than this table provides, use coldest data shown.
- For operation in outside air temperatures warmer than this table provides, use extreme caution.
- Aircraft with optional Air Conditioning System; Add 100 feet to ground roll distance and 150 feet to distance over 50' obstacle if Air Conditioner is ON during takeoff.

Takeoff Distance - 3400 LB

Weight: 3400 LB		Headwind: Subtract 10% for each 12 knots headwind.					
Speed at Liftoff: 73 KIAS		Tailwind: Add 10% for each 2 knots tailwind up to 10 knots.					
Speed over 50 Ft. Obstacle: 78 KIAS		Runway Slope: Reference Notes.					
Flaps: 50%		Dry Grass: Add 20% to Ground Roll.					
Power: Takeoff		Wet Grass: Add 30% to Ground Roll.					
Runway: Dry, Paved, Level		Air Conditioner: Add 100' to ground roll and 150' to distance over 50' obstacle if Air Conditioner if ON during takeoff.					
PRESS ALT FT	DISTANCE FT	TEMPERATURE ~°C					ISA
		0	10	20	30	40	
SL	Grnd Roll	917	990	1067	1146	1229	1028
	50 ft	1432	1539	1650	1764	1883	1594
1000	Grnd Roll	1011	1092	1176	1264	1355	1117
	50 ft	1574	1691	1813	1939	2069	1728
2000	Grnd Roll	1116	1206	1299	1395	1496	1215
	50 ft	1732	1861	1995	2133	2276	1874
3000	Grnd Roll	1234	1332	1435	1542	1653	1323
	50 ft	1907	2049	2196	2349	2507	2035
4000	Grnd Roll	1365	1474	1588	1706	1829	1441
	50 ft	2102	2259	2422	2590	2764	2212
5000	Grnd Roll	1512	1633	1758	1889	2025	1572
	50 ft	2320	2493	2673	2858	3051	2407
6000	Grnd Roll	1676	1810	1950	2095	2245	1717
	50 ft	2564	2755	2953	3159	3371	2622
7000	Grnd Roll	1861	2009	2164	2325	2492	1877
	50 ft	2837	3048	3267	3494	3729	2859
8000	Grnd Roll	2068	2233	2405	2584	2770	2054
	50 ft	3142	3376	3619	3871	4131	3122
9000	Grnd Roll	2302	2485	2677	2875	3082	2250
	50 ft	3485	3744	4014	4293	4581	3412
10000	Grnd Roll	2564	2769	2982	3204	3434	2468
	50 ft	3870	4158	4457	4767	5088	3733

Takeoff Distance - 2900 LB

Weight: 2900 LB Speed at Liftoff: 70 KIAS Speed over 50 Ft. Obstacle: 74 KIAS Flaps: 50% Power: Takeoff Runway: Dry, Paved, Level		Headwind: Subtract 10% for each 12 knots headwind. Tailwind: Add 10% for each 2 knots tailwind up to 10 knots. Runway Slope: Reference Notes. Dry Grass: Add 20% to Ground Roll. Wet Grass: Add 30% to Ground Roll. Air Conditioner: Add 100' to ground roll and 150' to distance over 50' obstacle if Air Conditioner if ON during takeoff.					
PRESS ALT FT	DISTANCE FT	TEMPERATURE ~°C					ISA
		0	10	20	30	40	
SL	Grnd Roll	610	659	710	763	818	684
	50 ft	971	1043	1118	1195	1275	1080
1000	Grnd Roll	673	727	783	841	902	743
	50 ft	1066	1146	1228	1313	1401	1170
2000	Grnd Roll	743	802	864	929	995	809
	50 ft	1173	1260	1351	1444	1541	1269
3000	Grnd Roll	821	887	955	1026	1100	880
	50 ft	1292	1388	1487	1590	1697	1378
4000	Grnd Roll	908	981	1057	1135	1217	959
	50 ft	1424	1530	1639	1753	1871	1498
5000	Grnd Roll	1006	1086	1170	1257	1348	1046
	50 ft	1571	1688	1809	1935	2065	1630
6000	Grnd Roll	1116	1205	1298	1394	1494	1143
	50 ft	1736	1865	1999	2138	2281	1775
7000	Grnd Roll	1238	1337	1440	1547	1659	1249
	50 ft	1920	2063	2211	2365	2523	1936
8000	Grnd Roll	1376	1486	1601	1720	1843	1367
	50 ft	2127	2285	2449	2619	2795	2113
9000	Grnd Roll	1532	1654	1781	1914	2051	1498
	50 ft	2359	2534	2716	2904	3099	2309
10000	Grnd Roll	1707	1843	1985	2132	2285	1643
	50 ft	2619	2814	3016	3225	3441	2527

Takeoff Climb Gradient

Conditions:

- PowerFull Throttle
- Mixture Set per Placard
- Flaps50%
- Airspeed.....Best Rate of Climb

• Note •

Climb Gradients shown are the gain in altitude for the horizontal distance traversed expressed as Feet per Nautical Mile.

Fuel flow must be set to the placarded limit for all takeoffs and climbs.

Cruise climbs or short duration climbs are permissible at best power as long as altitudes and temperatures remain within those specified in the table.

For operation in air colder than this table provides, use coldest data shown.

For operation in air warmer than this table provides, use extreme caution.

Weight LB	Press Altitude FT	Climb Speed KIAS	CLIMB GRADIENT ~ Feet per Nautical Mile				
			Temperature ~°C				
			-20	0	20	40	ISA
3400	SL	91	939	896	853	811	864
	2000	90	834	793	752	711	770
	4000	89	734	694	654	615	680
	6000	88	638	600	561	524	594
	8000	88	546	509	472	436	510
	10000	87	458	422	387	353	431
2900	SL	91	1172	1122	1070	1019	1083
	2000	90	1049	1000	950	902	972
	4000	89	931	884	836	790	867
	6000	88	818	773	727	683	766
	8000	88	711	667	623	581	669
	10000	87	608	566	524	484	576

Takeoff Rate of Climb

Conditions:

- Power..... Full Throttle
- Mixture..... Set per Placard
- Flaps..... 50%
- Airspeed Best Rate of Climb

• Note •

Rate-of-Climb values shown are change in altitude for unit time expended expressed in Feet per Minute.

Fuel flow must be set to the placarded limit for all takeoffs and climbs.

Cruise climbs or short duration climbs are permissible at best power as long as altitudes and temperatures remain within those specified in the table.

For operation in air colder than this table provides, use coldest data shown.

For operation in air warmer than this table provides, use extreme caution.

Aircraft with optional Air Conditioning System - Maximum rate of climb performance is reduced by approximately 50 feet per minute. For maximum climb performance the air-conditioner should be off.

Weight LB	Press Altitude FT	Climb Speed KIAS	RATE OF CLIMB ~ Feet per Minute				
			Temperature ~°C				
			-20	0	20	40	ISA
3400	SL	91	1326	1317	1300	1277	1304
	2000	90	1214	1200	1179	1153	1189
	4000	89	1100	1082	1057	1028	1074
	6000	88	985	962	934	901	958
	8000	88	869	842	809	774	843
	10000	87	851	719	683	644	727
2900	SL	91	1646	1638	1621	1598	1626
	2000	90	1518	1505	1484	1457	1494
	4000	89	1389	1371	1346	1316	1363
	6000	88	1259	1236	1207	1172	1232
	8000	88	1128	1100	1066	1028	1101
	10000	87	995	962	924	883	971

Enroute Climb Gradient

Conditions:

- PowerFull Throttle
- MixtureFull Rich
- Flaps0% (UP)
- Airspeed.....Best Rate of Climb

• Note •

Climb Gradients shown are the gain in altitude for the horizontal distance traversed expressed as Feet per Nautical Mile.

Fuel flow must be set to the placarded limit for all takeoffs and climbs.

Cruise climbs or short duration climbs are permissible at best power as long as altitudes and temperatures remain within those specified in the table.

For operation in air colder than this table provides, use coldest data shown.

For operation in air warmer than this table provides, use extreme caution.

Weight LB	Press Altitude FT	Climb Speed KIAS	CLIMB GRADIENT - Feet per Nautical Mile				
			Temperature ~°C				
			-20	0	20	40	ISA
3400	SL	101	911	867	823	781	834
	2000	100	813	771	729	689	748
	4000	99	720	679	639	600	665
	6000	98	630	590	552	515	584
	8000	97	544	505	468	433	507
	10000	96	461	424	388	354	433
	12000	95	381	346	312	279	361
	14000	94	304	271	238	207	292
16000	93	231	199	168	139	226	
2900	SL	101	1130	1078	1026	975	1039
	2000	100	1015	965	915	867	937
	4000	99	905	857	809	763	840
	6000	98	800	753	708	664	746
	8000	97	699	654	611	569	656
	10000	96	603	560	518	478	570
	12000	95	610	469	429	391	487
	14000	94	422	382	344	308	407
16000	93	337	299	263	229	331	

Enroute Rate of Climb

Conditions:

- Power..... Full Throttle
- Mixture..... As Required
- Flaps.....0% (UP)
- Airspeed Best Rate of Climb

• Note •

Rate-of-Climb values shown are change in altitude in feet per unit time expressed in Feet per Minute.

Fuel flow must be set to the placarded limit for all takeoffs and climbs.

Cruise climbs or short duration climbs are permissible at best power as long as altitudes and temperatures remain within those specified in the table.

For operation in air colder than this table provides, use coldest data shown.

For operation in air warmer than this table provides, use extreme caution.

Aircraft with optional Air Conditioning System; Maximum rate of climb performance is reduced by approximately 50 feet per minute if system is ON.

For maximum climb performance the air-conditioner should be off.

Weight	Press Altitude	Climb Speed	RATE OF CLIMB ~ Feet per Minute				
			Temperature ~°C				
			-20	0	20	40	ISA
LB	FT	KIAS					
3400	SL	101	1428	1414	1392	1366	1398
	2000	100	1311	1292	1267	1238	1279
	4000	99	1193	1170	1141	1108	1160
	6000	98	1074	1046	1013	977	1041
	8000	97	953	921	884	845	922
	10000	96	830	794	754	712	803
	12000	95	706	666	623	577	684
	14000	94	581	537	490	441	565
2900	16000	93	454	406	355	303	446
	SL	101	1761	1748	1726	1698	1732
	2000	100	1629	1610	1584	1552	1596
	4000	99	1494	1471	1441	1405	1461
	6000	98	1359	1331	1296	1257	1326
	8000	97	1222	1189	1151	1108	1191
	10000	95	1084	1046	1004	958	1056
	12000	95	945	902	855	806	921
2900	14000	93	804	757	706	653	787
	16000	92	662	610	556	499	653

Enroute Rate of Climb Vs Density Altitude

Conditions:

- Power Full Throttle
- Flaps 0% (UP)
- Airspeed Best Rate of Climb

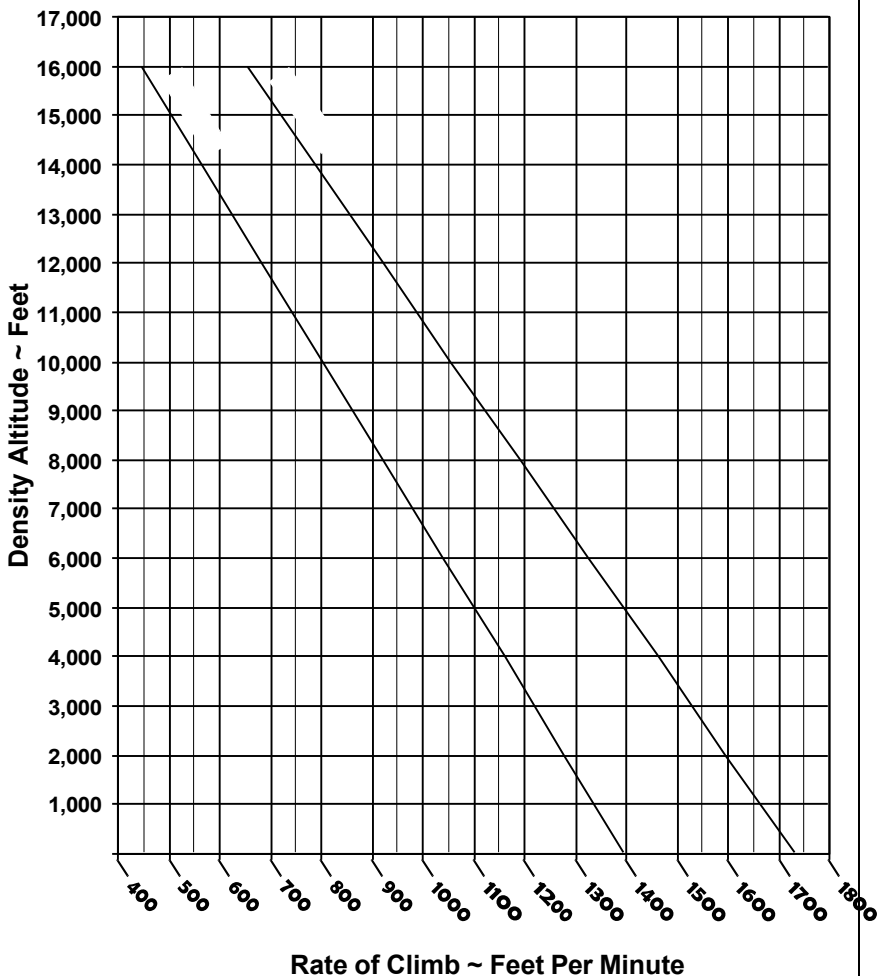

Time, Fuel and Distance to Climb

Conditions:

- Power..... Full Throttle
- Mixture..... Per Schedule, Section 4
- Fuel Density..... 6.0 LB/GAL
- Weight 3400 LB
- Winds..... Zero
- Climb Airspeed Noted

• Note •

Taxi Fuel - Add 1.5 gallon for start, taxi, and takeoff.

Temperature - Add 10% to computed values for each 10° C above standard.

Fuel flow must be set to the placarded limit for all takeoffs and climbs.

Cruise climbs or short duration climbs are permissible at best power as long as altitudes and temperatures remain within those specified in the table.

Press Alt FT	OAT (ISA) °C	Climb Speed KIAS	Rate Of Climb FPM	TIME, FUEL, DISTANCE ~ From Sea Level		
				Time Minutes	Fuel U.S. Gal	Distance NM
SL	15	101	1398	0.0	0.0	0.0
1000	13	100	1339	0.7	0.3	1.0
2000	11	100	1279	1.5	0.7	2.5
3000	9	99	1220	2.5	1.0	4.0
4000	7	99	1160	3.0	1.3	5.5
5000	5	97	1101	4.0	1.7	7.0
6000	3	98	1041	5.0	2.0	8.5
7000	1	96	982	6.0	2.4	10.5
8000	-1	97	922	7.0	2.7	12.0
9000	-3	95	863	8.0	3.1	14.5
10000	-5	95	803	9.5	3.5	16.5
11000	-7	94	744	10.5	3.9	19.0
12000	-9	95	684	12.0	4.4	21.5
13000	-11	93	625	13.5	4.8	24.5
14000	-13	93	565	15.0	5.3	28.0
15000	-15	92	506	17.0	5.8	31.5
16000	-17	92	446	19.0	6.4	35.5
17000	-19	91	387	21.5	7.1	40.0
17500	-20	91	357	24.0	7.8	45.5

Cruise Performance

Conditions:

- Cruise Weight..... 2900 LB
- Winds Zero
- Shaded Cells: Cruise Pwr above 85% not recommended.

• Note •

Subtract 10 KTAS if nose wheel pant and fairing removed. Lower KTAS by 10% if nose and main wheel pants & fairings are removed.

Aircraft with optional Air Conditioning System - Cruise performance is reduced by 2 knots. For maximum performance, the air-conditioner should be off.

Aircraft with optional Enhanced Vision System; Cruise performance is reduced by up to 1 knot.

Press Alt	ISA - 30°C					ISA			ISA + 30°C		
	RPM	MAP	PWR	KTAS	GPH	PWR	KTAS	GPH	PWR	KTAS	GPH
2000	2700	27.4	103%	186	24.6	98%	186	23.3	93%	181	22.0
	2600	27.4	99%	183	23.5	94%	183	22.2	89%	178	21.5
	2500	27.4	93%	179	22.1	88%	179	20.9	84%	174	20.8
	2500	26.4	89%	176	21.1	84%	176	19.9	80%	171	20.2
	2500	25.4	84%	173	20.0	80%	173	19.0	76%	168	19.5
	2500	24.4	80%	170	19.0	76%	170	18.0	72%	165	18.8
	2500	23.4	76%	167	18.0	72%	167	17.0	68%	162	18.1
4000	2700	25.4	96%	185	22.9	91%	185	21.6	87%	180	20.8
	2600	25.4	92%	182	21.9	87%	182	20.7	83%	177	20.6
	2500	25.4	87%	178	20.6	82%	178	19.5	78%	173	19.9
	2500	24.4	82%	175	19.5	78%	175	18.5	74%	170	19.2
	2500	23.4	78%	172	18.5	74%	172	17.5	70%	167	18.5
	2500	22.4	73%	169	17.4	69%	169	16.5	66%	163	17.7
	2500	21.4	69%	165	16.4	65%	165	15.5	62%	159	16.9
6000	2700	23.5	89%	184	21.2	85%	184	20.1	81%	179	19.6
	2600	23.5	85%	181	20.3	81%	181	19.2	77%	176	19.1
	2500	23.5	80%	177	19.1	76%	177	18.1	72%	172	18.3
	2500	22.5	76%	174	18.1	72%	174	17.1	68%	169	17.6
	2500	21.5	72%	170	17.0	68%	170	16.1	64%	165	16.9
	2500	20.5	67%	166	15.9	64%	166	15.1	60%	161	16.1
	2500	19.5	63%	162	14.9	59%	162	14.1	56%	157	15.3

Section 5
Performance Data

ATPI INC T1

Press Alt			ISA - 30°C			ISA			ISA + 30°C		
	RPM	MAP	PWR	KTAS	GPH	PWR	KTAS	GPH	PWR	KTAS	GPH
8000	2700	21.7	83%	183	19.7	78%	183	18.6	75%	178	17.7
	2600	21.7	79%	180	18.8	75%	180	17.8	71%	175	17.0
	2500	21.7	75%	176	17.7	71%	176	16.8	67%	171	16.0
	2500	20.7	70%	172	16.7	66%	172	15.8	63%	167	15.0
	2500	19.7	66%	168	15.6	62%	168	14.8	59%	163	14.0
	2500	18.7	61%	163	14.5	58%	163	13.8	55%	158	13.1
	2500	17.7	57%	159	13.5	54%	159	12.8	51%	153	12.1
10000	2700	20.0	77%	182	18.2	73%	182	17.3	69%	176	16.4
	2600	20.0	71%	177	17.0	68%	177	16.1	64%	172	15.3
	2500	20.0	67%	173	16.0	64%	173	15.1	61%	167	14.4
	2500	19.0	63%	168	14.9	59%	168	14.1	56%	163	13.4
	2500	18.0	58%	163	13.8	55%	163	13.1	52%	158	12.5
	2500	17.0	54%	158	12.8	51%	158	12.1	48%	153	11.5
12000	2700	18.5	71%	180	16.9	67%	180	16.0	64%	175	15.2
	2600	18.5	68%	177	16.2	64%	177	15.3	61%	172	14.5
	2500	18.5	64%	173	15.2	60%	173	14.4	58%	167	13.7
	2500	17.5	59%	168	14.1	56%	168	13.4	53%	162	12.7
	2500	16.5	55%	162	13.0	52%	162	12.3	49%	157	11.7
	2500	15.5	50%	156	12.0	48%	156	11.3	45%	151	10.8
14000	2700	17.1	66%	178	15.6	62%	178	14.8	59%	173	14.1
	2600	17.1	63%	175	14.9	60%	175	14.1	57%	170	13.5
	2500	17.1	59%	171	14.1	56%	171	13.3	53%	165	12.7
	2500	16.1	55%	165	13.0	52%	165	12.3	49%	159	11.7
	2500	15.1	50%	159	11.9	47%	159	11.2	45%	153	10.7
16000	2700	15.8	61%	176	14.5	58%	176	13.7	55%	171	13.0
	2600	15.8	58%	173	13.8	55%	173	13.1	52%	167	12.5
	2500	15.8	55%	168	13.0	52%	168	12.3	49%	163	11.7
	2500	14.8	50%	162	11.9	47%	162	11.3	45%	156	10.7
17000	2700	15.2	59%	175	13.9	55%	175	13.2	53%	169	12.5
	2600	15.2	56%	171	13.3	53%	171	12.6	50%	166	12.0
	2500	15.2	53%	167	12.5	50%	167	11.9	47%	162	11.3
	2500	14.2	48%	160	11.4	45%	160	10.8	43%	155	10.3

Range / Endurance Profile

Conditions:

- Weight..... 3400 LB
- Temperature..... Standard Day
- Winds..... Zero
- Mixture..... Best Economy
- Total Fuel..... 92 Gallons

• Note •

Fuel Remaining For Cruise is equal to 92.0 gallons usable, less climb fuel, less 9.8 gallons for 45 minutes IFR reserve fuel at 47% power (ISA @ 10,000 ft PA), less descent fuel, less fuel used prior to takeoff.

Range and endurance shown includes descent to final destination at approximately 178 KIAS and 500 fpm.

Range is decreased by 5% if nose wheel pant and fairings removed.

Range is decreased by 15% if nose and main wheel pants and fairings removed.

Aircraft with optional air-conditioning system - Range is decreased by 1%. For maximum range the air-conditioner should be off.

Aircraft with optional Enhanced Vision System; range is decreased by ½%.

75% POWER				Mixture: Best Power			
Press Alt	Climb Fuel	Fuel Remaining For Cruise	Airspeed	Fuel Flow	Endurance	Range	Specific Range
FT	Gal	Gal	KTAS	GPH	Hours	NM	Nm/Gal
SL	0.0	81.3	166	17.8	4.6	763	9.3
2000	0.7	81.1	170	17.8	4.6	775	9.6
4000	1.3	80.4	173	17.8	4.5	786	9.8
6000	2.0	79.7	177	17.8	4.5	797	10.0
8000	2.7	79.0	180	17.8	4.4	811	10.3

Range / Endurance Profile (Continued)

65% POWER					Mixture: Best Power		
Press Alt	Climb Fuel	Fuel Remaining For Cruise	Airspeed	Fuel Flow	Endurance	Range	Specific Range
FT	Gal	Gal	KTAS	GPH	Hours	NM	Nm/Gal
SL	0.0	81.3	158	15.4	5.3	838	10.3
2000	0.7	81.1	161	15.4	5.3	850	10.5
4000	1.3	80.4	165	15.4	5.2	862	10.7
6000	2.0	79.7	168	15.4	5.2	874	11.0
8000	2.7	79.0	171	15.4	5.1	887	11.2
10000	3.5	78.2	174	15.4	5.1	899	11.5
12000	4.4	77.1	178	15.4	5.0	912	11.8

55% POWER					Mixture: Best Power		
Press Alt	Climb Fuel	Fuel Remaining For Cruise	Airspeed	Fuel Flow	Endurance	Range	Specific Range
FT	Gal	Gal	KTAS	GPH	Hours	NM	Nm/Gal
SL	0.0	81.8	149	13.1	6.3	931	11.4
2000	0.7	81.1	152	13.1	6.2	943	11.6
4000	1.3	80.4	154	13.1	6.2	955	11.9
6000	2.0	79.7	157	13.1	6.1	968	12.2
8000	2.7	79.0	160	13.1	6.0	980	12.4
10000	3.5	78.3	163	13.1	6.0	993	12.7
12000	4.4	77.4	166	13.1	5.9	1005	13.0
14000	5.3	76.5	169	13.1	5.8	1018	13.4

55% POWER					Mixture: Best Economy		
Press Alt	Climb Fuel	Fuel Remaining For Cruise	Airspeed	Fuel Flow	Endurance	Range	Specific Range
FT	Gal	Gal	KTAS	GPH	Hours	NM	Nm/Gal
SL	0.0	81.8	149	11.3	7.2	1074	13.1
2000	0.7	81.1	152	11.3	7.2	1088	13.4
4000	1.3	80.4	154	11.3	7.1	1108	13.7
6000	2.0	79.7	157	11.3	7.0	1115	14.0
8000	2.7	79.0	160	11.3	7.0	1129	14.3
10000	3.5	78.3	163	11.3	6.9	1143	14.6
12000	4.4	77.4	166	11.3	6.8	1156	15.0
14000	5.3	76.5	169	11.3	6.7	1170	15.4

Balked Landing Climb Gradient

Conditions:

- PowerFull Throttle
- Mixture Set per Placard
- Flaps 100% (DN)
- Climb Airspeed..... VREF

• Note •

Balked Landing Climb Gradients shown are the gain in altitude for the horizontal distance traversed expressed as Feet per Nautical Mile.

For operation in air colder than this table provides, use coldest data shown.

For operation in air warmer than this table provides, use extreme caution.

This chart is required data for certification. However, significantly better performance can be achieved by climbing at Best Rate of Climb speeds shown with flaps down or following the Go-Around / Balked Landing procedure in Section 4.

Weight LB	Press Alt FT	Climb Speed KIAS	CLIMB GRADIENT ~ Feet/Nautical Mile					Best Rate of Climb KIAS
			Temperature ~°C					
			-20	0	20	40	ISA	
3400	SL	77	834	835	823	803	827	80
	2000	77	750	744	728	704	736	80
	4000	77	666	654	633	604	648	79
	6000	77	581	564	537	504	560	78
	8000	77	496	472	440	402	473	77
	10000	77	409	379	341	296	387	77
2900	SL	77	1069	1070	1056	1032	1060	
	2000	77	969	962	942	914	953	
	4000	77	869	855	829	796	847	
	6000	77	789	747	716	677	743	
	8000	77	668	639	602	556	641	
	10000	77	565	529	484	432	639	

Balked Landing Rate of Climb

Conditions:

- Power..... Full Throttle
- Mixture..... Set per Placard
- Flaps..... 100% (DN)
- Climb AirspeedVREF

• Note •

Balked Landing Rate of Climb values shown are the full flaps change in altitude for unit time expended expressed in Feet per Minute.

For operation in air colder than this table provides, use coldest data shown.

For operation in air warmer than this table provides, use extreme caution.

This chart is required data for certification. However, significantly better performance can be achieved by climbing at the Best Rate of Climb speeds shown with flaps down or following the Go-Around / Balked Landing procedure in Section 4.

Weight	Press Alt	Climb Speed	RATE OF CLIMB - Feet per Minute					Best Rate of Climb KIAS
			Temperature ~°C					
LB	FT	KIAS	-20	0	20	40	ISA	
3400	SL	77	996	1035	1057	1067	1053	80
	2000	77	930	959	972	971	966	80
	4000	77	858	876	878	867	878	79
	6000	77	779	784	775	752	784	78
	8000	77	691	683	660	623	684	77
	10000	77	593	571	532	478	578	77
2900	SL	77	1268	1318	1348	1363	1342	
	2000	77	1195	1233	1252	1255	1245	
	4000	77	1115	1140	1146	1137	1144	
	6000	77	1026	1037	1030	1007	1037	
	8000	77	927	923	900	861	923	
	10000	77	817	796	755	696	803	

Landing Distance

Conditions:

- Winds Zero
- Runway Dry, Level, Paved
- Flaps 100%
- Power 3° Power Approach
to 50 FT obstacle, then reduce power passing the estimated 50 foot point and smoothly continue power reduction to reach idle just prior to touchdown.

• Note •

The following factors are to be applied to the computed landing distance for the noted condition:

- Headwind - Subtract 10% from table distances for each 13 knots headwind.
- Tailwind - Add 10% to table distances for each 2 knots tailwind up to 10 knots.
- Grass Runway, Dry - Add 20% to ground roll distance.
- Grass Runway, Wet - Add 60% to ground roll distance.
- Sloped Runway - Increase table distances by 27% of the ground roll distance for each 1% of downslope. Decrease table distances by 9% of the ground roll distance for each 1% of upslope.

• Caution •

The above corrections for runway slope are required to be included herein. These corrections should be used with caution since published runway slope data is usually the net slope from one end of the runway to the other. Many runways will have portions of their length at greater or lesser slopes than the published slope, lengthening (or shortening) landing ground roll estimated from the table.

- For operation in outside air temperatures colder than this table provides, use coldest data shown.
- For operation in outside air temperatures warmer than this table provides, use extreme caution.

Landing Distance

WEIGHT: 3400 LB
Speed over 50 Ft Obstacle: 77 KIAS
Flaps: 100%
Power: Idle
Runway: Dry, Paved, Level

Headwind: Subtract 10% for each 13 knots headwind.
Tailwind: Add 10% for each 2 knots tailwind up to 10 knots.
Runway Slope: Reference Notes
Dry Grass: Add 20% to Ground Roll
Wet Grass: Add 60% to Ground Roll

PRESS ALT FT	DISTANCE FT	TEMPERATURE ~°C					ISA
		0	10	20	30	40	
SL	Grnd Roll	1082	1121	1161	1200	1240	1141
	Total	2262	2316	2372	2428	2485	2344
1000	Grnd Roll	1122	1163	1204	1245	1286	1175
	Total	2317	2374	2433	2492	2551	2391
2000	Grnd Roll	1163	1206	1248	1291	1334	1210
	Total	2375	2436	2497	2559	2621	2441
3000	Grnd Roll	1207	1251	1295	1339	1384	1247
	Total	2437	2501	2565	2630	2696	2493
4000	Grnd Roll	1252	1298	1344	1390	1436	1285
	Total	2503	2569	2637	2705	2774	2548
5000	Grnd Roll	1300	1348	1395	1443	1490	1324
	Total	2572	2642	2713	2785	2857	2605
6000	Grnd Roll	1350	1399	1449	1498	1547	1365
	Total	2645	2719	2794	2869	2945	2665
7000	Grnd Roll	1402	1453	1504	1556	1607	1408
	Total	2723	2800	2879	2958	3038	2728
8000	Grnd Roll	1456	1509	1563	1616	1669	1452
	Total	2805	2887	2969	3052	3136	2794
9000	Grnd Roll	1513	1569	1624	1679	1735	1497
	Total	2892	2978	3064	3152	3240	2863
10000	Grnd Roll	1573	1630	1688	1746	1803	1545
	Total	2984	3074	3165	3257	3350	2936

Section 6

Weight and Balance Data

Table of Contents

Introduction	3
Airplane Weighing Form	4
Airplane Weighing Procedures	5
Loading Instructions	8
Weight and Balance Loading Form	9
Loading Data	10
Moment Limits	11
Weight & Balance Record	12
Equipment List	13

Intentionally Left Blank

Introduction

This section describes the procedure for establishing the basic empty weight and moment of the airplane. Sample forms are provided for reference. Procedures for calculating the weight and moment for various operations are also provided. A comprehensive list of all equipment available for this airplane is included at the back of this section.

It should be noted that specific information regarding the weight, arm, moment, and installed equipment for this airplane as delivered from the factory can only be found in the plastic envelope carried in the back of this handbook.

It is the responsibility of the pilot to ensure that the airplane is loaded properly.

Airplane Weighing Form

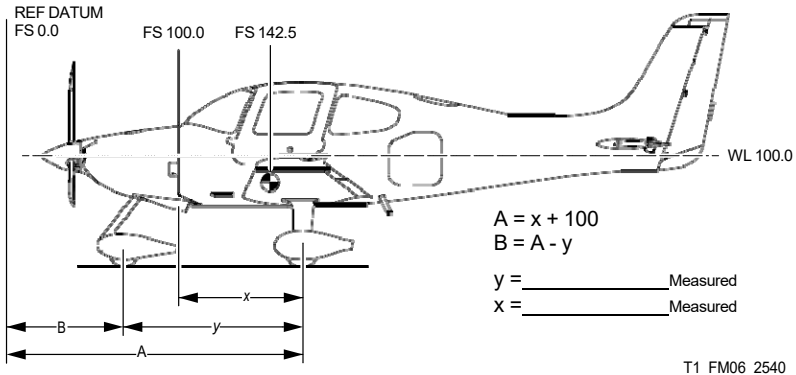

Weighing Point	Scale Reading	- Tare	= Net Weight	X Arm	= Moment
L Main				A=	
R Main				A=	
Nose				B=	
Total As Weighed				CG=	
CG = Total Moment / Total Weight					
<i>Space below provided for additions or subtractions to as weighed condition</i>					
Empty Weight				CG=	
Engine Oil (if oil drained) <i>15 lb at FS 78.4, moment = 1176</i>					
Unusable Fuel			15.0	154.9	2324
Basic Empty Weight				CG=	

Figure 6-1

Airplane Weighing Procedures

A basic empty weight and center of gravity were established for this airplane when the airplane was weighed just prior to initial delivery. However, major modifications, loss of records, addition or relocation of equipment, accomplishment of service bulletins, and weight gain over time may require re-weighing to keep the basic empty weight and center of gravity current. All changes to the basic empty weight and center of gravity are the responsibility of the operator.

1. Preparation:
 - a. Inflate tires to recommended operating pressures.
 - b. Service brake reservoir.
 - c. Drain fuel system.
 - d. Drain ice protection system.
 - e. Service engine oil.
 - f. Move crew seats to the most forward position.
 - g. Raise flaps to the fully retracted position.
 - h. Place all control surfaces in neutral position.
 - i. Verify equipment installation and location against equipment list.
2. Leveling:
 - a. Level longitudinally with a spirit level placed on the pilot door sill and laterally with of a spirit level placed across the door sills. Alternately, level airplane by sighting the forward and aft tool holes along waterline 95.9.
 - b. Place scales under each wheel (minimum scale capacity, 500 pounds nose, 1000 pounds each main).
 - c. Deflate the nose tire and/or shim underneath scales as required to properly center the bubble in the level.
3. Weighing:
 - a. With the airplane level, doors closed, and brakes released, record the weight shown on each scale. Deduct the tare, if any, from each reading.
4. Measuring:
 - a. Obtain measurement 'x' by measuring horizontally along the airplane center line (BL 0) from a line stretched between the

Weight and Balance Data

main wheel centers to a plumb bob dropped from the forward side of the firewall (FS 100). Add 100 to this measurement to obtain left and right weighing point arm (dimension 'A'). Typically, dimension 'A' will be in the neighborhood of 157.5.

- b. Obtain measurement 'y' by measuring horizontally and parallel to the airplane centerline (BL 0), from center of nosewheel axle, left side, to a plumb bob dropped from the line stretched between the main wheel centers. Repeat on right side and average the measurements. Subtract this measurement from dimension 'A' to obtain the nosewheel weighing point arm (dimension 'B').

5. Determine and record the moment for each of the main and nose gear weighing points using the following formula:

$$\text{Moment} = \text{Net Weight} \times \text{Arm}$$

6. Calculate and record the as-weighed weight and moment by totaling the appropriate columns.
7. Determine and record the as-weighed CG in inches aft of datum using the following formula:

$$\text{CG} = \text{Total Moment} / \text{Total Weight}$$

8. Add or subtract any items not included in the as-weighed condition to determine the empty condition. Application of the above CG formula will determine the C.G for this condition.
9. Add the correction for engine oil (15 lb at FS 78.4), if the airplane was weighed with oil drained. Add the correction for unusable fuel (15.0 lb at FS 154.9) to determine the Basic Empty Weight and Moment. Calculate and record the Basic Empty Weight CG by applying the above CG formula.
10. Record the new weight and CG values on the Weight and Balance Record.

The above procedure determines the airplane Basic Empty Weight, moment, and center of gravity in inches aft of datum. CG can also be expressed in terms of its location as a percentage of the airplane Mean Aerodynamic Cord (MAC) using the following formula:

$$\text{CG}\% \text{ MAC} = 100 \times (\text{CG Inches} - \text{LEMAC}) / \text{MAC}$$

Where:

$$\text{LEMAC} = 133.1$$

$$\text{MAC} = 47.7$$

Airplane Leveling

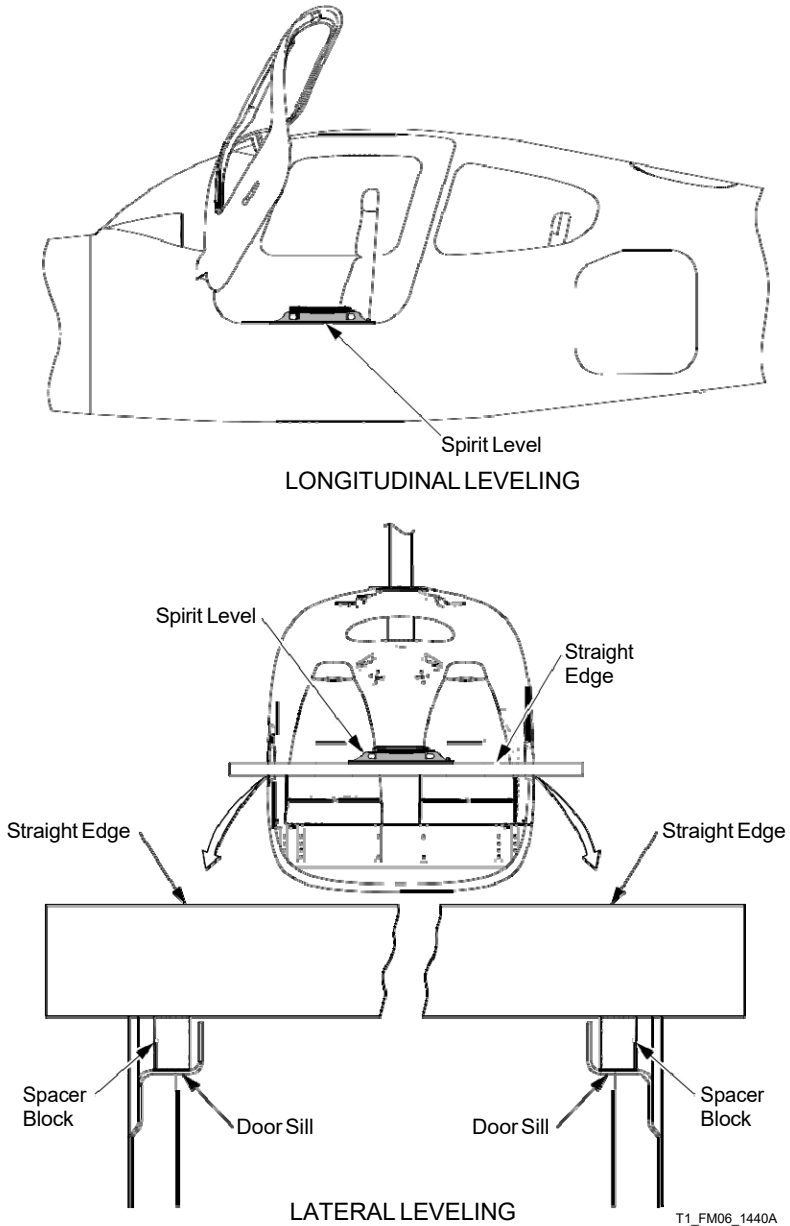

Figure 6-2

Loading Instructions

It is the responsibility of the pilot to ensure that the airplane is properly loaded and operated within the prescribed weight and center of gravity limits. The following information enables the pilot to calculate the total weight and moment for the loading. The calculated moment is then compared to the Moment Limits chart or table (*Figure 6-5*) for a determination of proper loading.

Airplane loading determinations are calculated using the Weight & Balance Loading Form (*Figure 6-3*), the Loading Data chart and table (*Figure 6-4*), and the Moment Limits chart and table (*Figure 6-5*).

1. **Basic Empty Weight** – Enter the current Basic Empty Weight and Moment from the Weight & Balance Record (*Figure 6-6*).
2. **Front Seat Occupants** – Enter the total weight and moment/1000 for the front seat occupants from the Loading Data (*Figure 6-4*).
3. **Rear Seat Occupants** – Enter the total weight and moment/1000 for the rear seat occupants from the Loading Data (*Figure 6-4*).
4. **Baggage** – Enter weight and moment for the baggage from the Loading Data (*Figure 6-4*).
 - If desired, subtotal the weights and moment/1000 from steps 1 through 4. This is the *Zero Fuel Condition*. It includes all useful load items excluding fuel.
5. **Fuel Loading** – Enter the weight and moment of usable fuel loaded on the airplane from the Loading Data (*Figure 6-4*).
 - Subtotal the weight and moment/1000. This is the *Ramp Condition* or the weight and moment of the aircraft before taxi.
6. **Fuel for start, taxi, and run-up** – This value is pre-entered on the form. Normally, fuel used for start, taxi, and run-up is approximately 9 pounds at an average moment/1000 of 1.394.
7. **Takeoff Condition** – Subtract the weight and moment/1000 for step 8 (start, taxi, and run-up) from the Ramp Condition values (step 7) to determine the Takeoff Condition weight and moment/1000.
 - The total weight at takeoff must not exceed the maximum weight limit of 3400 pounds. The total moment/1000 must not be above the maximum or below the minimum moment/1000 for the Takeoff Condition Weight as determined from the Moment Limits chart or table (*Figure 6-5*).

Weight and Balance Loading Form

• Note •

The Takeoff Condition Weight must not exceed 3400 lb.

The Takeoff Condition Moment must be within the Minimum Moment to Maximum Moment range at the Takeoff Condition Weight. (Refer to Moment Limits).

Serial Num: _____ Date: _____

Reg. Num: _____ Initials: _____

Item	Description	Weight LB	Moment/ 1000
1.	Basic Empty Weight <i>Includes unusable fuel & full oil</i>		
2.	Front Seat Occupants <i>Pilot & Passenger (total)</i>		
3.	Rear Seat Occupants		
4.	Baggage Area <i>130 lb maximum</i>		
5.	Zero Fuel Condition Weight <i>Sub total item 1 thru 4</i>		
6.	Fuel Loading <i>92 Gallon @ 6.0 lb/gal. Maximum</i>		
7.	Ramp Condition Weight <i>Sub total item 5 and 6</i>		
8.	Fuel for start, taxi, and run-up <i>Normally 9 lb at average moment of 1394.</i>	—	—
9.	Takeoff Condition Weight <i>Subtract item 8 from item 7</i>		

Figure 6-3

Loading Data

Use the following chart or table to determine the moment/1000 for fuel and payload items to complete the Loading Form.

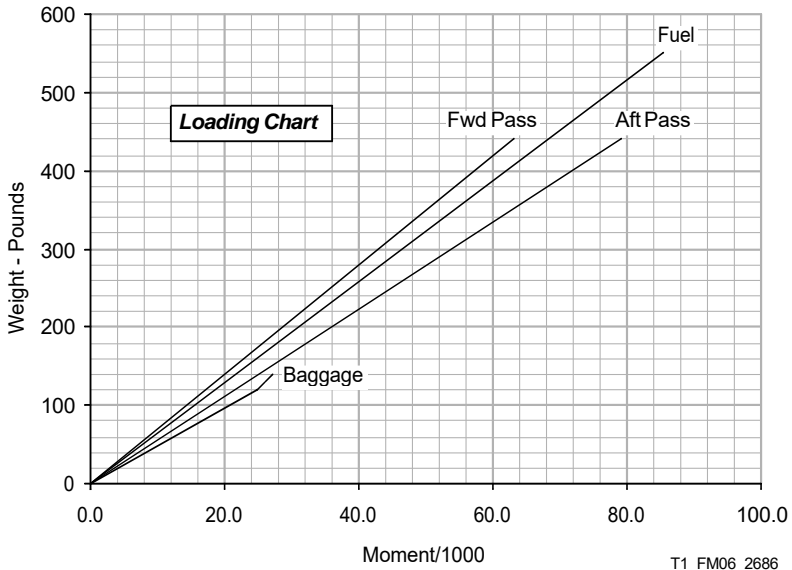

Weight LB	Fwd Pass FS 143.5	Aft Pass FS 180.0	Baggage FS 208.0	Fuel FS 154.9	Weight LB	Fwd Pass FS 143.5	Aft Pass FS 180.0	Fuel FS 154.9
20	2.9	3.6	4.2	3.1	300	43.1	54.0	46.5
40	5.7	7.2	8.3	6.2	320	45.9	57.6	49.6
60	8.6	10.8	12.5	9.3	340	48.8	61.2	52.7
80	11.5	14.4	16.6	12.4	360	51.7	64.8	55.8
100	14.4	18.0	20.8	15.5	380	54.5	68.4	58.9
120	17.2	21.6	25.0	18.6	400	57.4	72.0	62.0
140	20.1	25.2	27.04*	21.7	420	60.3	75.6	65.1
160	23.0	28.8		24.8	440	63.1	79.2	68.2
180	25.8	32.4		27.9	460			71.3
200	28.7	36.0		31.0	480			74.4
220	31.6	39.6		34.1	500			77.5
240	34.4	43.2		37.2	520			80.5
260	37.3	46.8		40.3	552**			85.5
280	40.2	50.4		43.4				

*130 lb Maximum

**92 U.S. Gallons Usable

Figure 6-4

Moment Limits

Use the following chart or table to determine if the weight and moment from the completed Weight and Balance Loading Form (Figure 6-3) are within limits.

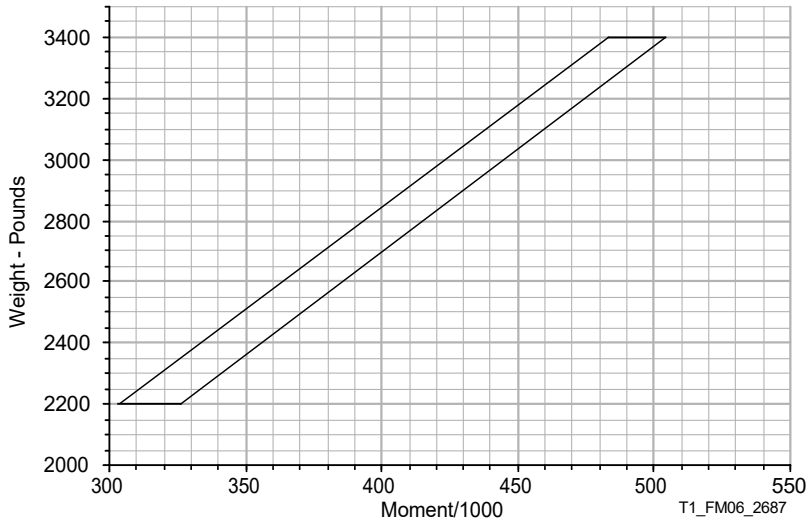

Weight LB	Moment/1000		Weight LB	Moment/1000	
	Minimum	Maximum		Minimum	Maximum
2200	304	326	2850	398	422
2250	311	333	2900	406	430
2300	318	341	2950	414	437
2350	326	348	3000	421	444
2400	333	355	3050	429	452
2450	340	363	3100	437	459
2500	347	370	3150	444	467
2550	354	378	3200	452	474
2600	362	385	3250	460	481
2650	369	392	3300	467	489
2700	375	400	3350	475	496
2750	383	407	3400	483	504
2800	390	415			

Figure 6-5

Equipment List

This list will be determined after the final equipment has been installed in the aircraft.

Intentionally Left Blank

Section 7

Airplane and Systems Description

Table of Contents

Introduction	5
Airframe	6
Fuselage	6
Wings	6
Empennage	7
Flight Controls	8
Elevator System	8
Aileron System	10
Rudder System	12
Control Locks	12
Instrument Panel	14
Pilot Panel Arrangement	14
Center Console Arrangement	14
Bolster Panel Arrangement	14
Flight Instruments	16
Attitude Indicator	18
Airspeed Indicator	19
Altimeter	20
Horizontal Situation Indicator	21
Vertical Speed Indicator	21
Magnetic Compass	22
Wing Flaps	22
Flap Control Switch	22
Landing Gear	24
Main Gear	24
Nose Gear	24
Brake System	24
Baggage Compartment	26
Seats	27
Seat Belt and Shoulder Harness	28
Cabin Doors	29
Windshield and Windows	29
Engine	30
Engine Controls	30
Engine Indicating	32
Engine Lubrication System	36

Airplane and Systems Description

Ignition and Starter System	36
Air Induction System	36
Engine Exhaust.....	37
Engine Fuel Injection	37
Engine Cooling.....	37
Propeller	38
Fuel System	39
Fuel Selector Valve.....	40
Fuel Pump Operation.....	40
Fuel Indicating.....	42
Electrical System.....	46
Power Generation	46
Power Distribution.....	48
Electrical System Protection.....	49
Electrical System Control.....	52
Ground Service Receptacle.....	53
Electrical Indicating	54
Lighting Systems	56
Exterior Lighting	56
Interior Lighting	57
Environmental System	59
Distribution	60
Heating.....	60
Cooling	61
Airflow Selection	64
Vent Selection	64
Temperature Selection	65
Stall Warning System.....	67
Preflight Check.....	67
Pitot-Static System.....	68
Pitot Heat Switch.....	68
Pitot Heat Annunciation	68
Alternate Static Source	68
Avionics	70
Integrated Integrated Avionics System.....	70
Optional Avionics	78
Avionics Support Equipment	83
Cabin Features.....	85
Emergency Locator Transmitter	85
Fire Extinguisher	86
Hour Meters	87
Emergency Egress Hammer	87

Convenience Outlet87
ATPI Airplane Parachute System88
System Description.....88
Activation Handle.....89
Deployment Characteristics91

Intentionally Left Blank

Introduction

This section provides a basic description and operation of the standard airplane and its systems. Optional equipment described within this section is identified as optional.

• Note •

Some optional equipment may not be described in this section. For description and operation of optional equipment not described in this section, refer to Section 9, Supplements.

Airframe

Fuselage

The airplane's monocoque fuselage is constructed primarily of composite materials and is designed to be aerodynamically efficient. The cabin area is bounded on the forward side by the firewall at fuselage station 100, and on the rear by the aft baggage compartment bulkhead at fuselage station 222. Comfortable seating is provided for four adults. A composite roll cage within the fuselage structure provides roll protection for the cabin occupants. The cabin and baggage compartment floors are constructed of a foam core composite with access to under-floor components.

All flight and static loads are transferred to the fuselage structure from the wings and control surfaces through four wing attach points in two locations under the front seats and two locations on the sidewall just aft of the rear seats.

The lower firewall employees a 20° bevel to improve crashworthiness. In addition, an avionics bay is located aft of bulkhead 222 and accessible through an access panel installed on the RH side of the aft fuselage.

Wings

The wing structure is constructed of composite materials producing wing surfaces that are smooth and seamless. The wing cross section is a blend of several high-performance airfoils. A high aspect ratio results in low drag. Each wing provides attach structure for the main landing gear and contains a 47.25-gallon fuel tank.

The wing is constructed in a conventional spar, rib, and shear section arrangement. The upper and lower skins are bonded to the spar, ribs, and aft shear web forming a torsion box that carries all of the wing bending and torsion loads. The rear shear webs are similar in construction but do not carry through the fuselage. The main spar is laminated epoxy/carbon fiber in a C-section, and is continuous from wing tip to wing tip. The wing spar passes under the fuselage below the two front seats and is attached to the fuselage in two locations. Lift and landing loads are carried by the single carry-through spar, plus a pair of rear shear webs (one on each wing) attached to the fuselage.

Empennage

The empennage consists of a horizontal stabilizer, a two-piece elevator, a vertical fin and a rudder. All of the empennage components are conventional spar (shear web), rib, and skin construction.

The horizontal stabilizer is a single composite structure from tip to tip. The two-piece elevator, attached to the horizontal stabilizer, is aluminum.

The vertical stabilizer is composite structure integral to the main fuselage shell for smooth transfer of flight loads. The rudder is aluminum and is attached to the vertical stabilizer rear shear web at three hinge points.

Flight Controls

The airplane uses conventional flight controls for ailerons, elevator and rudder. The control surfaces are pilot controlled through either of two single-handed side control yokes mounted beneath the instrument panel. The location and design of the control yokes allow easy, natural use by the pilot. The control system uses a combination of push rods, cables and bell cranks for control of the surfaces.

Elevator System

The two-piece elevator provides airplane pitch control. The elevator is of conventional design with skin, spar and ribs manufactured of aluminum. Each elevator half is attached to the horizontal stabilizer at two hinge points and to the fuselage tail-cone at the elevator control sector. Elevator motion is generated through the pilot's control yokes by sliding the yoke tubes forward or aft in a bearing carriage. A push-pull linkage is connected to a cable sector mounted on a torque tube. A single cable system runs from the forward elevator sector under the cabin floor to the aft elevator sector pulley. A push-pull tube connected to the aft elevator sector pulley transmits motion to the elevator bellcrank attached to the elevators.

Pitch Trim System

Pitch trim is provided by adjusting the neutral position of the compression spring cartridge in the elevator control system by means of an electric motor. It is possible to easily override full trim or autopilot inputs by using normal control inputs. A ground adjustable trim tab is installed on the elevator to provide small adjustments in neutral trim. This tab is factory set and does not normally require adjustment. An electric motor changes the neutral position of the spring cartridge attached to the elevator control horn. A conical trim button located on top of each control yoke controls the motor. Moving the switch forward will initiate nose-down trim and moving the switch aft will initiate nose-up trim. Neutral (takeoff) trim is indicated by the alignment of a reference mark on the yoke tube with a tab attached to the instrument panel bolster. The elevator trim also provides a secondary means of airplane pitch control in the event of a failure in the primary pitch control system not involving a jammed elevator.

Elevator (pitch) trim operates on 28 VDC supplied through the 2-amp PITCH TRIM circuit breaker on ESS BUS 2.

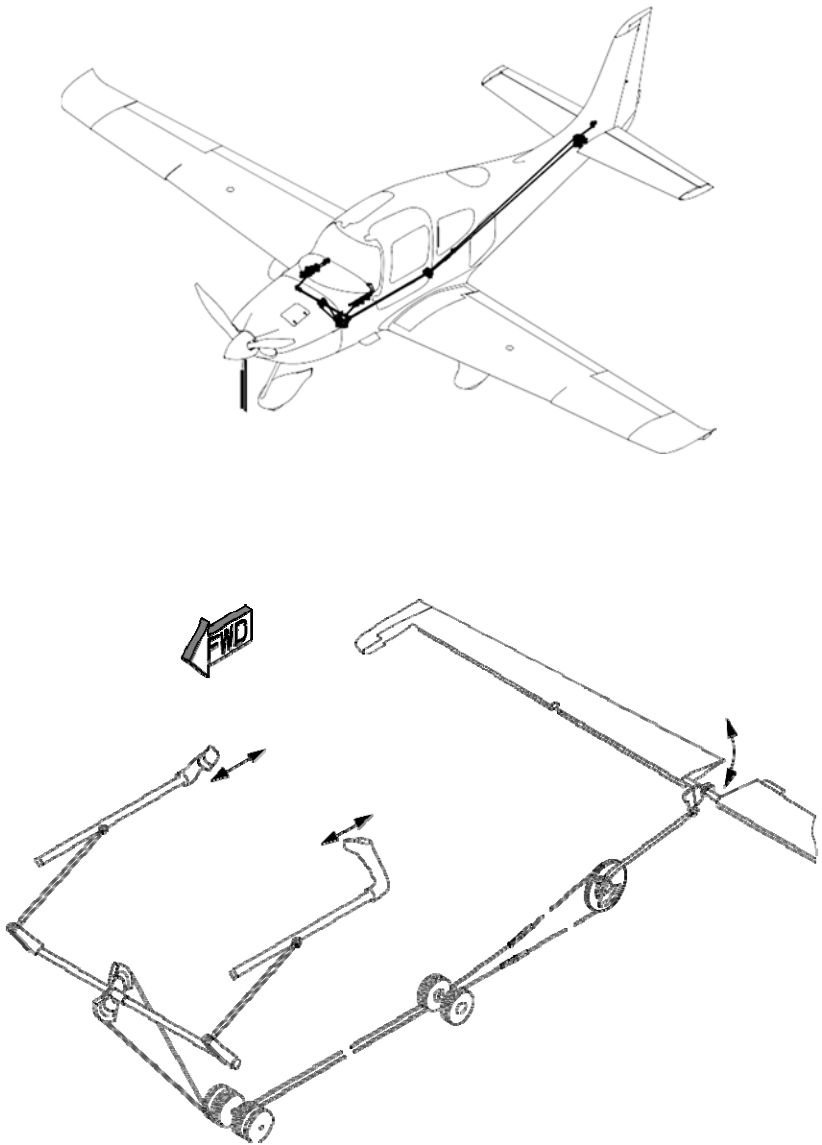

T1_FM07_1461

Figure 7-1
Elevator System

Aileron System

The ailerons provide airplane roll control. The ailerons are of conventional design with skin, spar and ribs manufactured of aluminum. Each aileron is attached to the wing shear web at two hinge points.

Aileron control motion is generated through the pilot's control yokes by rotating the yokes in pivoting bearing carriages. Push rods link the pivoting carriages to a centrally located pulley sector. A single cable system runs from the sector to beneath the cabin floor and aft of the rear spar. From there, the cables are routed in each wing to a vertical sector/crank arm that rotates the aileron through a right angle conical drive arm.

Roll Trim System

Roll trim is provided by adjusting the neutral position of a compression spring cartridge in the aileron control system by means of an electric motor. The electric roll trim is also used by the autopilot to position the ailerons. It is possible to easily override full trim or autopilot inputs by using normal control inputs.

A ground adjustable trim tab is installed on the right aileron to provide small adjustments in neutral trim. This tab is factory set and does not normally require adjustment.

An electric motor changes the neutral position of a spring cartridge attached to the left actuation pulley in the wing. A conical trim button located on top of each control yoke controls the motor. Moving the switch left will initiate left-wing-down trim and moving the switch right will initiate right-wing-down trim. Neutral trim is indicated by the alignment of the line etched on the control yoke with the centering indication marked on the instrument panel. The aileron trim also signed t a secondary means of airplane roll control in the event of a failure in the primary roll control system not involving jammed ailerons.

Aileron trim operates on 28 VDC supplied through the 2-amp ROLL TRIM circuit breaker on ESS BUS 2.

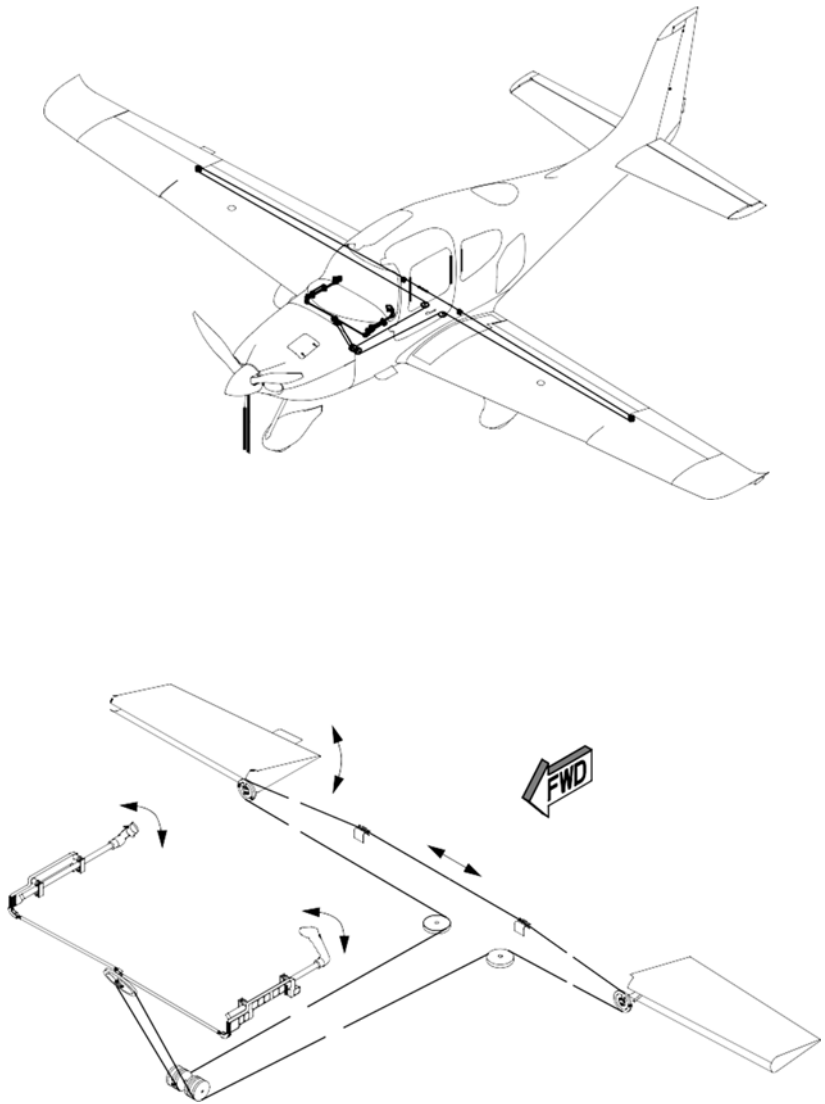

T1_FM07_1462

Figure 7-2
Aileron System

Rudder System

The rudder provides airplane directional (yaw) control. The rudder is of conventional design with skin, spar and ribs manufactured of aluminum. The rudder is attached to the aft vertical stabilizer shear web at three hinge points and to the fuselage tail-cone at the rudder control bell crank.

Rudder motion is transferred from the rudder pedals to the rudder by a single cable system under the cabin floor to a sector next to the elevator sector pulley in the aft fuselage. A push-pull tube from the sector to the rudder bell crank translates cable motion to the rudder. Springs and a ground adjustable spring cartridge connected to the rudder pedal assembly tension the cables and provide centering force.

Yaw Trim System

Yaw trim is provided by spring cartridge attached to the rudder pedal torque tube and console structure. The spring cartridge provides a centering force regardless of the direction of rudder deflection. The yaw trim is ground adjustable only.

A ground adjustable trim tab is installed on the rudder to provide small adjustments in neutral trim. This tab is factory set and does not normally require adjustment.

Control Locks

The airplane's control system is not equipped with gust locks. The trim spring cartridges have sufficient power to act as a gust damper without rigidly locking the position.

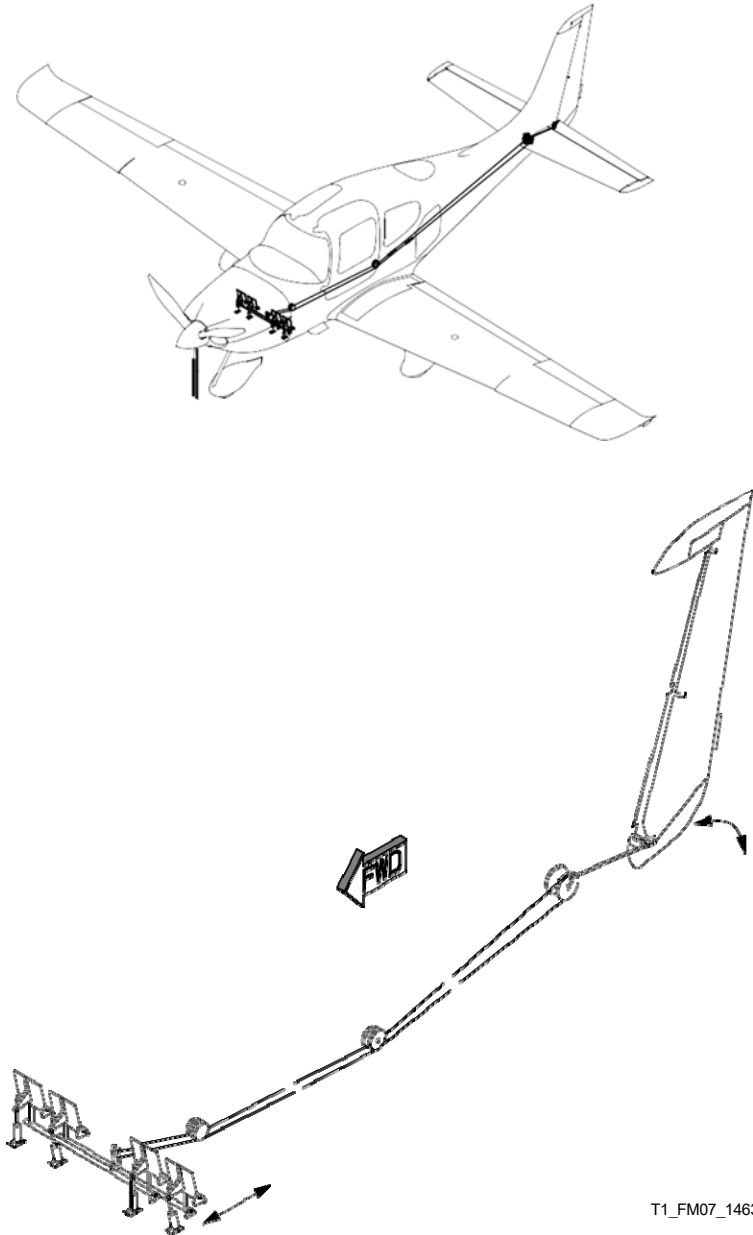

T1_FM07_1463

Figure 7-3
Rudder System

Instrument Panel

The instrument panel is of all metal construction and is installed in sections so equipment can be easily removed for maintenance. The surrounding glareshield is made of composite material and projects over the instrument panel to reduce reflections on the windshield from lighted equipment and to shield the panel equipment from glare.

Pilot Panel Arrangement

Two color landscape-oriented electronic flight displays are installed to the instrument panel; the Primary Flight Display (PFD) and the Multifunction Display (MFD). The PFD, installed directly in front of the pilot, is intended to be the primary display of flight parameter information (attitude, airspeed, heading, and altitude). The MFD, installed to the right of the PFD, provides supplemental situational and navigation information to the pilot. The ignition switch is located on the left side of the instrument panel. The cabin environmental control switches are located on the right side of the instrument panel. Instrument panel air vents are located on the outboard sections of the panel.

Center Console Arrangement

A center console contains the Flight Management System Keyboard, autopilot and audio controls, flap system control and indication, fuel system indicator and controls, and the power and mixture levers. System circuit breakers, the alternate static source valve, alternate induction air control, and the ELT panel switch are located on the left side of the console. A friction knob for adjusting throttle and mixture control feel and position stability is located on the right side of the console. The accessory outlet, map compartment, audio jacks, hour meters, and emergency egress hammer are installed inside the console armrest.

Bolster Panel Arrangement

A switch panel located in the “dash board” bolster below the instrument panel contains the master, avionics power, ice protection (optional), Pitot heat, and exterior and interior lighting switches and controls. The standby airspeed, attitude, and altimeter instruments are located below bolster switch panel.

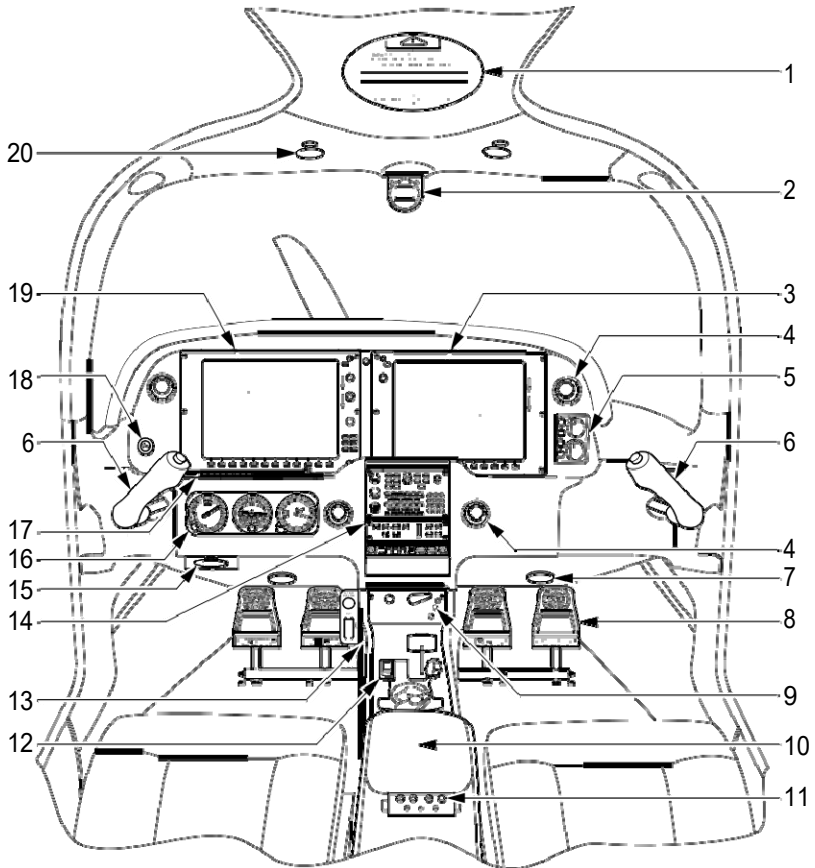

Legend

- | | |
|--|--|
| <ul style="list-style-type: none"> 1. ATPI Airframe Parachute System (APS) Activation T-Handle Cover 2. Magnetic Compass 3. Multifunction Display 4. Fresh Air "Eyeball" Outlet 5. Temperature/Ventilation Controls 6. Control Yoke 7. Conditioned Air Outlet 8. Rudder Pedals 9. Flap Control & Position Indicators 10. Armrest 11. Passenger Audio Jacks 12. Engine & Fuel System Controls | <ul style="list-style-type: none"> 13. Left Side Console <ul style="list-style-type: none"> · Circuit Breaker Panel · Alternate Engine Air · ELT Remote Switch · Alternate Static Source 14. Avionics Panel 15. Parking Brake 16. Flight Instrument Panel 17. Bolster Switch Panel 18. Start/Ignition Key Switch 19. Primary Flight Display 20. Overhead Light & Switch |
|--|--|

T1_FM07_2688A

Figure 7-4
Instrument Panel and Console

Flight Instruments

Flight instruments and annunciations are displayed on the Primary Flight Display (PFD) located directly in front of the pilot. The PFD presents the primary flight instruments arranged in the conventional basic “T” configuration. Standby instruments for airspeed, attitude and altitude are mounted on the LH bolster panel and are on separate power sources than the PFD.

Knobs, knob sets, and membrane-type push button switches are located along the inboard edge of the PFD and MFD and provide control for communication (COM), navigation (NAV), heading (HDG), barometric pressure set (BARO), and various Flight Management functions. For electrical requirements and additional information on PFD and MFD integration, refer to the Integrated Avionics System description in this section.

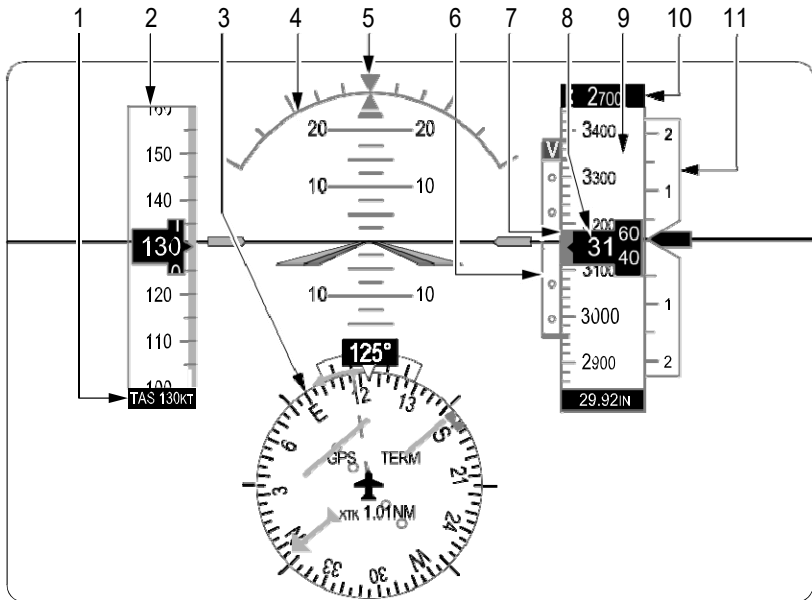

LEGEND

- 1. True Airspeed
- 2. Airspeed Indicator
- 3. Horizontal Situation Indicator (HSI)
- 4. Altitude Indicator
- 5. Slip/Skid Indicator
- 6. Vertical Deviation Indicator (VDI)
- 7. Selected Altitude Bug
- 8. Current Altitude
- 9. Altimeter
- 10. Selected Altitude
- 11. Vertical Speed Indicator (VSI)
- 12. Current Heading
- 13. Lubber Line
- 14. Selected Heading Bug
- 15. Flight Phase
- 16. Navigation Source
- 17. Aircraft Symbol
- 18. Course Deviation Scale
- 19. Rotating Compass Rose
- 20. Course Pointer

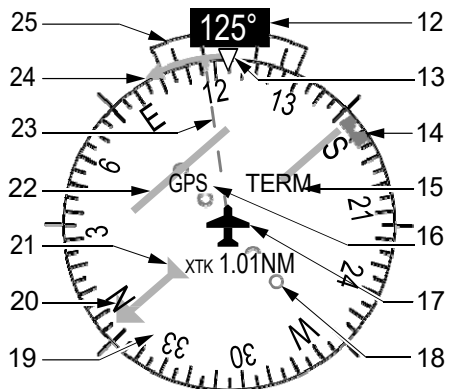

HSI DETAIL

- 21. To/From Indicator
- 22. Course Deviation Indicator
- 23. Current Track Indicator
- 24. Turn Rate/Heading Trend Vector
- 25. Turn Rate Indicator

T1_FM07_2790

Figure 7-5
Flight Instruments

Airplane and Systems Description**Attitude Indicator**

The primary attitude indicator is shown on the upper center of the PFD and displays pitch, roll, and slip/skid information provided by the Attitude and Heading Reference System (AHRS).

Above and below the horizon line, major pitch marks and labels are shown for every 10°, up to 80°. Between 25° below and 45° above the horizon line, the pitch index scale is graduated in 5° increments with every 10° of pitch labeled. Between 20° below and 20° above the horizon line, minor pitch marks occur every 2.5°. If pitch limits are exceeded in either the nose-up or nose-down attitude, red warning chevrons will appear and point the way back to level flight. The roll index scale is graduated with major tick marks at 30° and 60° and minor tick marks at 10°, 20°, and 45°. The roll pointer is slaved to the airplane symbol. The slip-skid indicator is the bar beneath the roll pointer. The indicator moves with the roll pointer and moves laterally away from the pointer to indicate lateral acceleration. Slip/skid is indicated by the location of the bar relative to the pointer. One bar displacement is equal to one ball displacement on a traditional slip/skid indicator.

Standby Attitude Indicator

The standby attitude indicator is mounted on the LH bolster panel and gives backup indication of flight attitude. Bank attitude is indicated by a pointer at the top of the indicator relative to the bank scale with index marks at 10°, 20°, 30°, 60°, and 90° either side of the center mark. A fixed miniature airplane superimposed over a movable mask containing a white symbolic horizon bar, which divides the mask into two sections, indicates pitch and roll attitudes. The upper “blue sky” section and the lower “earth” sections have pitch reference lines useful for pitch attitude control. A knob at the bottom of the instrument allows adjustment of the miniature airplane to the horizon bar for a more accurate flight attitude indication. A PULL TO CAGE knob on the indicator is used for quick erection of the gyro. When the caging knob is pulled, the pitch and roll indications will align to within 2° of their respective fixed references. The standby attitude indicator is electrically driven. A red GYRO flag indicates loss of electrical power. Redundant circuits paralleled through diodes at the indicator supply DC electrical power for gyro operation.

28 VDC for attitude gyro operation is supplied through the 5-amp STDBY ATTD 1 circuit breaker on the ESS BUS 1 and the 5-amp STDBY ATTD 2 circuit breaker on the MAIN BUS 1.

Airspeed Indicator

Primary airspeed data is provided by the Air Data Computer and is shown as a vertical tape along the upper left side of the PFD. The airspeed scale is graduated with major tick marks at intervals of 10 knots and minor tick marks at intervals of 5 knots. Speed indication starts at 20 knots, with 60 knots of airspeed viewable at any time. The actual airspeed is displayed inside the black pointer. The pointer remains black until reaching the never-exceed speed (V_{NE}), at which point it turns red. Color coded bars are provided to indicate flap operating range, normal operating range, caution range, and never-exceed speed. Speeds above the never-exceed speed, appear in the high-speed warning range, represented on the airspeed tape by red/white "barber pole" coloration. Calculated true airspeed is displayed in window at the bottom edge of the airspeed tape. Airspeed trend is also displayed as a bar along-side of the airspeed tape.

Standby Airspeed Indicator

The standby airspeed indicator is mounted on the LH bolster panel and displays indicated and true airspeeds on a dual-scale, internally lit precision airspeed indicator installed in the pilot's instrument panel. The instrument senses difference in static and Pitot pressures and displays the result in knots on an airspeed scale. A single pointer sweeps an indicated airspeed scale calibrated from 40 to 220 knots. The 'zero' index is at the 12 o'clock position. A sub-scale aligns true airspeed with the corresponding indicated airspeed when the altitude/temperature correction is set in the correction window. A knob in the lower left corner of the instrument is used to rotate the pressure altitude scale in the correction window to align the current pressure altitude with the outside air temperature.

Altimeter

Primary altitude data is provided by the Air Data Computer and is shown as a vertical tape along the upper right side of the PFD. The altimeter scale is graduated with major tick marks at intervals of 100 feet and minor tick marks at intervals of 20 feet. Six hundred (600) feet of barometric altitude is viewable at any time.

The local barometric pressure is set using the barometric adjustment knob on the PFD. The selectable altitude reference bug is displayed on the altimeter tape and is set using the altitude selection knob on the Flight Management System Keyboard. Barometric minimum descent altitude (MDA, or Decision Height, DH), can be preset. Altimeter trend is also displayed as a bar along side of the altimeter tape.

The PFD Altitude is corrected for static source position error (normal static source / 0% flaps), the altitude calibration errors for the PFD are zero with flaps up and normal source (typical cruise flight). Calibration corrections are only necessary when flaps are extended or the alternate static source is selected

Standby Altimeter

Airplane altitude is depicted on a conventional, three-pointer, internally lit barometric altimeter installed on the LH bolster panel. The instrument senses the local barometric pressure adjusted for altimeter setting and displays the result on the instrument in feet. The altimeter is calibrated for operation between -1000 and 20,000 feet altitude. The scale is marked from 0 to 10 in increments of 2. The long pointer indicates hundreds of feet and sweeps the scale every 1000 feet (each increment equals 20 feet). The short, wide pointer indicates thousands of feet and sweeps the scale every 10,000 feet (each increment equals 200 feet). The short narrow pointer indicates tens of thousands feet and sweeps from 0 (zero) to 2 (20,000 feet with each increment equal to 2000 feet). Barometric windows on the instrument's face allow barometric calibrations in either inches of mercury (in.Hg) or millibars (mb). The barometric altimeter settings are input through the barometric adjustment knob at the lower left of the instrument.

The standby altimeter does not have automatic position error corrections, calibration corrections are necessary. Because the PFD has automatic corrections and the standby does not, differences between the two indications are typical (difference is the greatest at high altitudes and high airspeeds, where the position error corrections are the highest).

Horizontal Situation Indicator

The horizontal situation indicator is displayed along the lower center of the PFD. Heading data is provided by the Attitude and Heading Reference System (AHRS) and the onboard magnetometers. The HSI displays a rotating compass card in a heading-up orientation. Letters indicate the cardinal points and numeric labels occur every 30°. Major tick marks are at 10° intervals and minor tick marks at 5° intervals. Reference index marks are provided at 45° intervals around the compass card. A circular segment scale directly above the rotating compass card shows half and standard rates of turn based on the length of the turn rate trend vector.

The HSI presents heading, turn rate, course deviation, bearing, and navigation source information in a 360° compass-rose format. The HSI contains a Course Deviation Indicator (CDI) with a course pointer arrow, a To/From arrow, a sliding deviation bar, and scale. The course pointer is a single line arrow (GPS, VOR1, and LOC1) or a double line arrow (VOR2 and LOC2) which points in the direction of the set course. The To/From arrow rotates with the course pointer and is displayed when the active NAVAID is received.

The HSI heading reference bug is set using the heading selection knob on the Flight Management System Keyboard. The selected heading is displayed in a window above the upper LH 45° index mark and will disappear approximately 3 seconds after the heading selection knob stops turning.

The Course Deviation Indicator (CDI) navigation source shown on the HSI is set using the CDI softkey to select GPS, NAV1, or NAV2 inputs. The course pointer is set using the course selection knob on the Flight Management System Keyboard. The selected course is displayed in a window above the upper RH 45° index mark and will disappear approximately 3 seconds after the heading selection knob stops turning.

Vertical Speed Indicator

Vertical Speed data is provided by the Air Data Computer and is shown as a vertical tape along the right side of the altimeter on the PFD. The VSI scale is graduated with major tick marks at 1000 and 2000 fpm in each direction and minor tick marks at intervals of 500 feet. The vertical speed pointer moves up and down the fixed VSI scale and shows the rate of climb or descent in digits inside the pointer. A reference notch at the RH end of the scale indicates 0 feet/min.

Airplane and Systems Description

Vertical speed must exceed 100 feet/min before digits will appear in the VSI pointer. If the rate of ascent/descent exceeds 2000 fpm, the pointer appears at the corresponding edge of the tape and the rate appears inside the pointer.

Magnetic Compass

A conventional, internally lighted, liquid filled, magnetic compass is installed on the cabin headliner immediately above the windshield. A compass correction card is installed with the compass.

Wing Flaps

The electrically controlled, single-slotted flaps provide low-speed lift enhancement. Each flap is manufactured of aluminum and connected to the wing structure at three hinge points. Rub strips are installed on the top leading edge of each flap to prevent contact between the flap and wing flap cove. The flaps are selectively set to three positions: 0%, 50% (16°) and 100% (32°) by operating the FLAP control switch. The FLAP control switch positions the flaps through a motorized linear actuator mechanically connected to both flaps by a torque tube. Proximity switches in the actuator limit flap travel to the selected position and provide position indication.

The wing flaps are powered by 28 VDC through the 10-amp FLAPS circuit breaker on the NON ESS BUS.

The flaps control switch and indicator lights are powered by 28 VDC through the KEYPADS/AP CTRL circuit breaker on MAIN BUS 1.

Flap Control Switch

An airfoil-shaped FLAPS control switch is located at the bottom of the vertical section of the center console. The control switch is marked and has detents at three positions: UP (0%), 50% and 100%. The appropriate V_{FE} speed is marked at the Flap 50% and 100% switch positions. Setting the switch to the desired position will cause the flaps to extend or retract to the appropriate setting. An indicator light at each control switch position illuminates when the flaps reach the selected position. The UP (0%) light is green and the 50% and 100% lights are yellow.

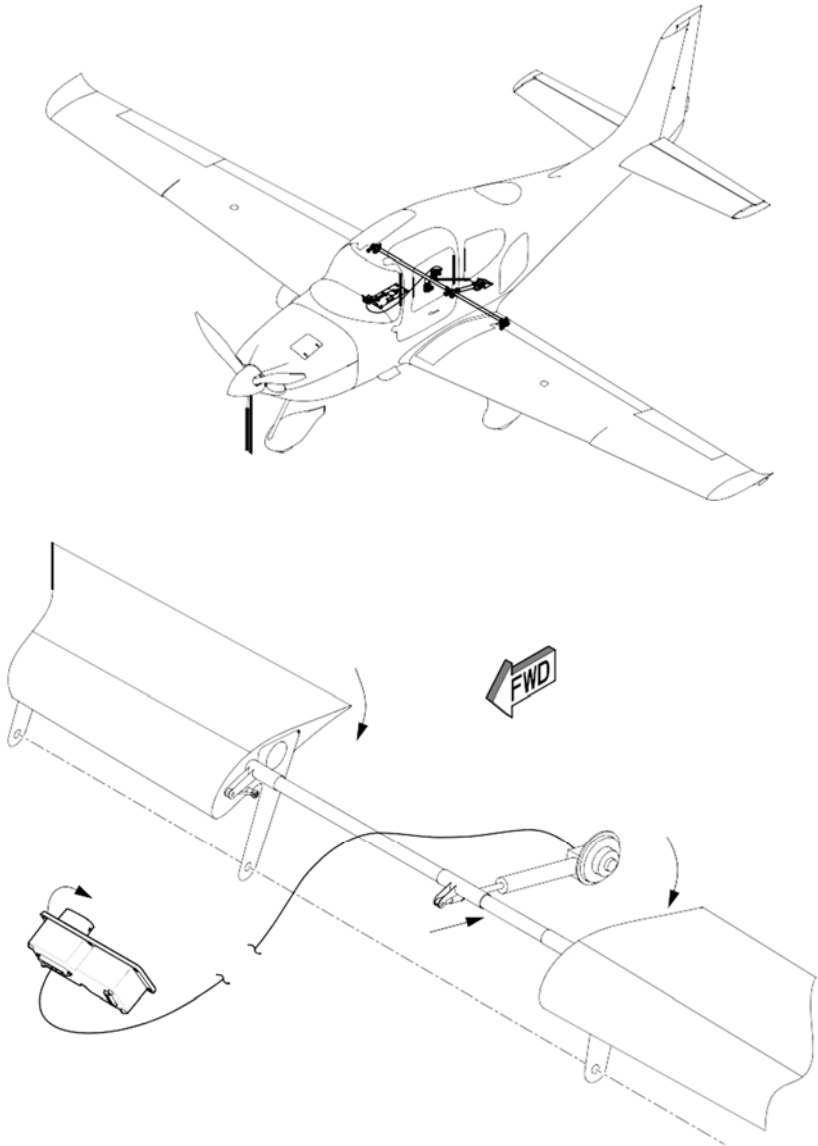

T1_FM07_2935A

Figure 7-6
Wing Flaps

Landing Gear

Main Gear

The main landing gear are bolted to composite wing structure between the wing spar and shear web. The landing gear struts are constructed of composite material for fatigue resistance. The composite construction is both rugged and maintenance free. The main wheels and wheel pants are bolted to the struts. Each main gear wheel has a 15 x 6.00 x 6 tire with inner-tube installed. Standard wheel pants are easily removable to provide access to tires and brakes. Access plugs in the wheel pants can be removed to allow tire inflation and pressure checking. Each main gear wheel is equipped with an independent, hydraulically operated single cylinder, dual piston, disc brake.

Nose Gear

Serials 0002 thru 2437:

The nose gear strut is of tubular steel construction and is attached to the steel engine mount structure. The nose wheel is free casting and can turn through an arc of approximately, *Serials 1005 thru 1885*, 216 degrees (108 degrees either side of center) or, *Serials 1886 and subs*, 170 degrees (85 degrees either side of center). Nose gear shock absorption is provided by polymer shock absorbing pucks. Steering is accomplished by differential application of individual main gear brakes. The tube-type nosewheel tire measures 5.00 x 5.

Serials 2438 & subs:

The nose gear strut is of tubular steel construction and is attached to the steel engine mount structure. The nose wheel is free casting and can turn through an arc of approximately 170 degrees (85 degrees either side of center). Nose gear shock absorption is accomplished by an oleo strut. Steering is accomplished by differential application of individual main gear brakes. The tube-type nosewheel tire measures 5.00 x 5.

Brake System

The main wheels have hydraulically operated, single-disc type brakes, individually activated by floor mounted toe pedals at both pilot stations. A parking brake mechanism holds induced hydraulic pressure on the disc brakes for parking. The brake system consists of a master cylinder for each rudder pedal, a hydraulic fluid reservoir, a parking brake valve, a single disc brake assembly on each main landing gear

wheel, temperature sensors, and associated hydraulic plumbing and wiring.

Braking pressure is initiated by depressing the top half of a rudder pedal (toe brake). The brakes are plumbed so that depressing either the pilot's or copilot's left or right toe brake will apply the respective (left or right) main wheel brake. The reservoir is serviced with Mil-H-5606 hydraulic fluid.

Brake system malfunction or impending brake failure may be indicated by a gradual decrease in braking action after brake application, noisy or dragging brakes, soft or spongy pedals, excessive travel, and/or weak braking action. A temperature sensitive resistor is mounted to each brake assembly which transmit signals via the Engine Airframe Unit to the Engine Indicating System for brake temperature caution/warning annunciation.

Should any of these symptoms occur, immediate maintenance is required. If, during taxi or landing roll, braking action decreases, let up on the toe brakes and then reapply the brakes with heavy pressure. If the brakes are spongy or pedal travel increases, pumping the pedals may build braking pressure.

Refer to Section 10, Safety Information, for Brake System operational considerations.

Parking Brake

• Caution •

Do not set the PARK BRAKE in flight. If a landing is made with the parking brake valve set, the brakes will maintain any pressure applied after touchdown.

The main wheel brakes are set for parking by using the PARK BRAKE handle on the right-side kick plate near the pilot's right knee. Brake lines from the toe brakes to the main wheel brake calipers are plumbed through a parking brake valve. For normal operation, the handle is pushed in. With the handle pushed in, poppets in the valve are mechanically held open allowing normal brake operation. When the handle is pulled out, the parking brake valve holds applied brake pressure, locking the brakes. To apply the parking brake, set the brakes with the rudder-pedal toe brakes, and then pull the PARK BRAKE handle aft.

Baggage Compartment

The baggage compartment door, located on the left side of the fuselage aft of the wing, allows entry to the baggage compartment. The baggage door is hinged on the forward edge and latched on the rear edge. The door is locked from the outside with a key lock. The baggage compartment key will also open the cabin doors.

The baggage compartment extends from behind the rear passenger seat to the aft cabin bulkhead. The rear seats can be folded forward to provide additional baggage area for long or bulky items.

Four baggage tie-down straps are provided to secure baggage and other items loaded in the baggage compartment. Each strap assembly has a hook at each end and a cam-lock buckle in the middle. The hook ends clip over loop fittings installed in the baggage floor and in the aft bulkhead. The tie-down straps should be stowed attached and tightened to the fittings.

• Caution •

If not adequately restrained, baggage compartment items may pose a projectile hazard to cabin occupants in the event of rapid deceleration. Secure all baggage items with tie-down straps.

To install tie-down strap:

1. Position straps over baggage. Thread straps through luggage handles if possible.
2. Clip hook ends of straps over loop fittings.
3. Grasp the buckle and pull the loose strap end of each strap to tighten straps over contents of baggage compartment.

To loosen tie-down straps:

1. Lift buckle release and pull on buckle to loosen strap.
2. Lift hook ends free of loop fittings.

Seats

The seating arrangement consists of two individually adjustable seats for the pilot and front seat passenger and two individual seats with fold down seat backs for the rear seat passengers. The front seats are adjustable fore and aft and the seat backs can be reclined for passenger comfort or folded forward for rear seat access. Integral headrests are provided. The fore and aft travel path is adjusted through the seat position control located below the forward edge of the seat cushion. The seat track is angled upward for forward travel so that shorter people will be positioned slightly higher as they adjust the seat forward. Recline position is controlled through levers located on each side of the seat backs. Depressing the recline release control while there is no pressure on the seat back will return the seat back to the full up position.

• Caution •

Do not kneel or stand on the seats. The seat bottoms have an integral aluminum honeycomb core designed to crush under impact to absorb downward loads.

To position front seat fore and aft:

1. Lift the position control handle.
2. Slide the seat into position.
3. Release the handle and check that the seat is locked in place.

To adjust recline position:

1. Actuate and hold the seat back control lever.
2. Position the seat back to the desired angle.
3. Release the control lever.

Each rear seat consists of a fixed seat bottom, a folding seat back, and a headrest. The seat backs can be unlatched from inside the baggage compartment and folded forward to provide a semi-flat surface for bulky cargo extending forward from the baggage compartment.

To fold seat back forward:

1. From the baggage access, lift the carpet panel at lower aft edge of seat to reveal the seat back locking pins (attached to lanyards).
2. Remove the locking pins and fold seat forward.

Seat Belt and Shoulder Harness

Integrated seat belt and shoulder harness assemblies with inertia reels are provided for the pilot and each passenger. The rear seat belts are attached to fittings on the floorboard and the forward seat belts are attached to the seat frame. The shoulder harnesses are attached to inertia reels mounted in the seat back for the front seats and on the baggage compartment rear bulkhead for the rear seats. Each harness is attached to the seat belt. The buckle half of each assembly is on the left-hand side and the link half is on the right-hand side. The inertia reels allow complete freedom of movement of the occupant's upper torso. In the event of a sudden deceleration, the reels lock automatically to protect the occupants. It is recommended that the seat belts be stowed in the latched position when not in use.

An inflatable shoulder harness is integral to each crew seat harness. The electronic module assembly, mounted below the cabin floor, contains a crash sensor, battery, and related circuitry to monitor the deceleration rate of the airplane. In the event of a crash, the sensor evaluates the crash pulse and sends a signal to an inflator assembly mounted to the aft seat frame. This signal releases the gas in the inflator and rapidly inflates the airbag within the shoulder harness cover, after airbag deployment, the airbag deflates to enable the pilot/co-pilot to egress the airplane without obstruction.

The crash sensor's predetermined deployment threshold does not allow inadvertent deployment during normal operations, such as hard landings, strikes on the seat, or random vibration.

• Caution •

No slack may exist between the occupant's shoulder and restraint harness shoulder strap.

Stow the seat belts in the latched position when not in use.

To use the restraints:

1. Slip arms behind the harness so that the harness extends over shoulders.
2. Hold the buckle and firmly insert the link.
3. Grasp the seat belt tabs outboard of the link and buckle and pull to tighten. Buckle should be centered over hips for maximum comfort and safety.

4. Restraint harnesses should fit snug against the shoulder with the lap buckle centered and tightened around the hips.

To release the restraints:

1. Grasp the top of the buckle opposite the link and pull outward. The link will slip free of buckle.
2. Slip arms from behind the harness.

Cabin Doors

Two large forward hinged doors allow crew and passengers to enter and exit the cabin. The door handles engage latching pins in the door frame receptacles at the upper aft and lower aft door perimeter. Gas charged struts provide assistance in opening the doors and hold the doors open against gusts. Front seat armrests are integrated with the doors. A key lock in each door provides security. The cabin door keys also fit the baggage compartment door lock. Separate keys are provided for the fuel APS.

Windshield and Windows

The windshield and side windows are manufactured of acrylic. Use only clean soft cloths and mild detergent to clean acrylic surfaces. Refer to Section 8 for detailed cleaning instructions.

Engine

The airplane is powered by a Teledyne Continental IO-550-N, six-cylinder, normally aspirated, fuel-injected engine rated to 310 hp at 2700 RPM. The engine has a 2000-hour Time Between Overhaul (TBO). Dual, conventional magnetos provide ignition.

The engine is attached to the firewall by a six-point steel engine mount. The firewall attach points are structurally reinforced with gusset-type attachments that transfer thrust and bending loads into the fuselage shell.

Engine Controls

Engine controls are easily accessible to the pilot on a center console. They consist of a single-lever power (throttle) control and a mixture control lever. A friction control wheel, labeled FRICTION, on the right side of the console is used to adjust control lever resistance to rotation for feel and control setting stability.

Power (Throttle) Lever

The single-lever throttle control, labeled MAX-POWER-IDLE, on the console adjusts the engine throttle setting in addition to automatically adjusting propeller speed. The lever is mechanically linked by cables to the air throttle body/fuel-metering valve and to the propeller governor. Moving the lever towards MAX opens the air throttle butterfly and meters more fuel to the fuel manifold. A separate cable to the propeller governor adjusts the governor oil pressure to increase propeller pitch to maintain engine RPM. The system is set to maintain approximately 2500 RPM throughout the cruise power settings and 2700 RPM at full power.

Mixture Control

The mixture control lever, labeled RICH-MIXTURE-CUTOFF, on the console adjusts the proportion of fuel to air for combustion. The Mixture Control Lever is mechanically linked to the mixture control valve in the engine-driven fuel pump. Moving the lever forward (towards RICH) repositions the valve allowing greater proportions of fuel and moving the lever aft (towards CUTOFF) reduces (leans) the proportion of fuel. The full aft position (CUTOFF) closes the control valve.

Alternate Air Control

An Alternate Induction Air Control knob, labeled ALT AIR – PULL, is installed on the left console near the pilot's right knee. To operate the control, depress the center lock button, pull the knob to the open position, and then release the lock button. Pulling the knob opens the alternate air induction door on the engine induction air manifold, bypasses the air filter, and allows warm unfiltered air to enter the engine. Alternate induction air should be used if blocking of the normal air source is suspected. Operation using alternate induction air should be minimized and the cause of filter blocking corrected as soon as practical.

Engine Indicating

Engine information is displayed as analog-style gages, bar graphs, and text on the MFD's ENGINE page. When the ENGINE page is not active or in the case of an electronic display failure (backup mode), all essential engine information is displayed along the LH edge of the display. Engine data is acquired by the Engine Airframe Unit which transmits the data to the Engine Indicating System for display as described in the following pages.

• Note •

A "Red X" through any electronic display field indicates that the display field is not receiving valid data and should be considered inoperative.

Engine System Annunciations

Engine system health, caution, and warning messages are displayed in color-coded text in the Crew Alerting System (CAS) window located to the right of the Altimeter and Vertical Speed Indicator. In combination with a CAS alert, the affected engine parameter displayed on the ENGINE page changes to the corresponding color of CAS alert and the annunciation system issues an audio alert.

For specific pilot actions in response to Engine System Annunciations, refer to the Engine System procedures contained in Section 3 - Emergency Procedures, and Section 3A - Abnormal Procedures.

For additional information on Engine Instrument Markings and Annunciations, refer to Section 2 - Limitations.

For additional information on the System Annunciations and Alerts, refer to the Integrated Avionics System description in this section.

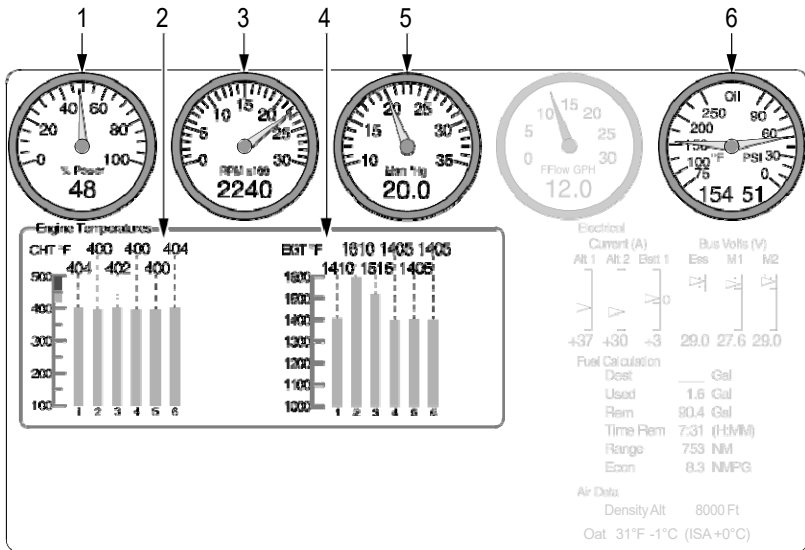

Engine Instruments

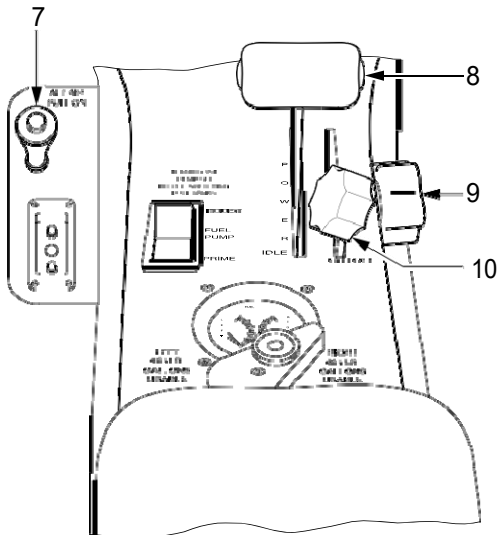

Engine Controls

- LEGEND**
1. Percent Power
 2. CHT
 3. Tachometer
 4. EGT
 5. Manifold Pressure
 6. Oil Temperature and Pressure
 7. Alternate Air Control
 8. Power Lever
 9. Friction Control
 10. Mixture Control

T1_FM07_2796

Figure 7-7
Engine Controls and Indicating

Airplane and Systems Description***Tachometer***

Engine speed (RPM) is shown in the upper mid-left corner of the ENGINE page as both a simulated tachometer and as a digital value. The tachometer pointer sweeps a scale range from 0 to 3000 RPM in 100 RPM increments. The digital RPM value is displayed in increments of 10 RPM in white numerals below the gage.

The tachometer receives a speed signal from a magnetic pickup sensor on the right hand magneto from the Engine Indicating System via the Engine Airframe Unit.

Exhaust Gas Temperature (EGT)

Exhaust gas temperatures for all six cylinders are displayed in the Engine Temperature block of the ENGINE page as vertical bars. The EGT graph is marked from 1000°F to 1600°F in 100°F increments. The digital EGT value of the cylinder is displayed above the bar in white numerals. A sensor in the exhaust pipe of each cylinder measures exhaust gas temperature and provides a voltage signal to the Engine Airframe Unit which processes and transmits the data to the Engine Indicating System.

Cylinder Head Temperature (CHT)

Cylinder head temperatures for all six cylinders are displayed in the Engine Temperature block of the ENGINE page as vertical bars. The CHT graph is marked from 100°F to 500°F in 100°F increments. The digital CHT value of the cylinder is displayed above the bar in white numerals.

A sensor in each cylinder head measures cylinder head temperature and provides a voltage signal to the Engine Airframe Unit which processes and transmits the data to the Engine Indicating System.

Oil Temperature

Oil temperature is shown in the upper right corner of the ENGINE page, opposite the oil pressure scale, as both a simulated temperature gage and as a digital value. The gage pointer sweeps a scale range from 75°F to 250°F in 50°F increments. The digital temperature value is displayed in white numerals below the gage.

The oil temperature sensor is mounted below the oil cooler and provides a signal to the Engine Airframe Unit that is processed and transmitted to the Engine Indicating System for display.

Oil Pressure

Oil Pressure is shown in the upper right corner of the ENGINE page, opposite the oil temperature scale, as both a simulated pressure gage and as a digital value. The gage pointer sweeps a scale range from 0 to 90 PSI in 10 PSI increments. The digital pressure value is displayed in white numerals below the gage.

The oil pressure sensor is mounted below the oil cooler and provides a signal to the Engine Airframe Unit that is processed and transmitted to the Engine Indicating System for display.

Manifold Pressure Gage

Manifold pressure is shown in the upper center portion of the ENGINE page as both a simulated pressure gage and as a digital value. The gage pointer sweeps a scale range from 10 to 35 inches Hg in 1 inch Hg increments. The digital MAP value is displayed in white numerals below the gage. The manifold pressure sensor is mounted in the induction air manifold near the throttle body and provides a signal to the Engine Airframe Unit that is processed and transmitted to the Engine Indicating System for display.

Percent Power Gage

Percent power is shown in the upper left corner of the ENGINE page as both a simulated gage and as a digital value. The percent power gage sweeps a scale marked from 0 to 100 percent in 5 percent increments. The digital percent power value is displayed in white numerals below the gage. The display units calculate the percentage of maximum engine power produced by the engine based on an algorithm employing manifold pressure, indicated air speed, outside air temperature, pressure altitude, engine speed, and fuel flow.

Engine Lubrication System

The engine is provided with a wet-sump, high-pressure oil system for engine lubrication and cooling. Oil for engine lubrication is drawn from an eight-quart capacity sump through an oil suction strainer screen and directed through the oil filter to the engine-mounted oil cooler by a positive displacement oil pump. The oil pump is equipped with a pressure relief valve at the pump output end to bypass oil back to the pump inlet should the pump exceed limits. The oil cooler is equipped with a temperature control valve set to bypass oil if the temperature is below approximately 180°F (82°C). Bypass or cooled oil is then directed through oil galleries to the engine rotating parts and piston inner domes. Oil is also directed to the propeller governor to regulate propeller pitch. The complete oil system is contained in the engine. An oil filler cap and dipstick are located at the left rear of the engine. The filler cap and dipstick are accessed through a door on the top left side of the engine cowling.

Ignition and Starter System

Two engine-driven magnetos and two spark plugs in each cylinder provide engine fuel ignition. The right magneto fires the lower right and upper left spark plugs, and the left magneto fires the lower left and upper right spark plugs. Normal operation is conducted with both magnetos, as more complete burning of the fuel-air mixture occurs with dual ignition. A rotary-type key switch, located on the instrument panel, controls ignition and starter operation. The switch is labeled OFF-R-L- BOTH-START. In the OFF position, the starter is electrically isolated, the magnetos are grounded and will not operate. Normally, the engine is operated on both magnetos (switch in BOTH position) except for magneto checks and emergency operations. The R and L positions are used for individual magneto checks and for single magneto operation when required. When the battery master switch is ON, rotating the switch to the spring loaded START position energizes the starter and activates both magnetos. The switch automatically returns to the BOTH position when released.

28 VDC for Starter operation is supplied through the 2-amp STARTER circuit breaker on NON-ESSENTIAL BUS.

Air Induction System

Induction air enters the engine compartment through the two inlets in the forward cowling. The air passes through a dry-foam induction filter,

through the throttle butterfly, into the six-tube engine manifold, and finally through the cylinder intake ports into the combustion chambers. Should the dry induction filter become clogged, a pilot controlled alternate induction air door can be opened, allowing engine operation to continue as described below. For additional information on the Alternate Air Control, refer to Engine Controls - Alternate Air Control description in this section.

Engine Exhaust

Engine exhaust gases are routed through a tuned exhaust system. After leaving the cylinders, exhaust gases are routed through the exhaust manifold, through mufflers located on either side of the engine, then overboard through exhaust pipes exiting through the lower cowling. A muff type heat exchanger, located around the right muffler, provides cabin heat.

Engine Fuel Injection

The multi-nozzle, continuous-flow fuel injection system supplies fuel for engine operation. An engine driven fuel pump draws fuel from the selected wing tank and passes it to the mixture control valve integral to the pump. The mixture control valve proportions fuel in response to the pilot operated mixture control lever position. From the mixture control, fuel is routed to the fuel-metering valve on the air-induction system throttle body. The fuel-metering valve adjusts fuel flow in response to the pilot-controlled Power Lever position. From the metering valve, fuel is directed to the fuel manifold valve (spider) and then to the individual injector nozzles. The system meters fuel flow in proportion to engine RPM, mixture setting, and throttle angle. Manual mixture control and idle cut-off are provided. An electric fuel pump provides fuel boost for vapor suppression and for priming.

Engine Cooling

Engine cooling is accomplished by discharging heat to the oil and then to the air passing through the oil cooler, and by discharging heat directly to the air flowing past the engine. Cooling air enters the engine compartment through the two inlets in the cowling. Aluminum baffles direct the incoming air to the engine and over the engine cylinder cooling fins where the heat transfer takes place. The heated air exits the engine compartment through two vents in the aft portion of the cowling. No movable cowl flaps are used.

Propeller

The airplane is equipped with a constant-speed, aluminum-alloy propeller with a three-blade (78" diameter) propeller and governor.

The propeller governor automatically adjusts propeller pitch to regulate propeller and engine RPM. The propeller governor senses engine speed by means of flyweights and senses throttle setting through a cable connected to the power (throttle) control lever in the cockpit. The propeller governor boosts oil pressure in order to regulate propeller pitch position. Moving the throttle lever forward causes the governor to meter less high-pressure oil to the propeller hub allowing centrifugal force acting on the blades to lower the propeller pitch for higher RPM operation. Reducing the power (throttle) lever position causes the governor to meter more high-pressure oil to the propeller hub forcing the blades to a higher pitch, lower RPM, position. During stabilized flight, the governor automatically adjusts propeller pitch in order to maintain an RPM setting (throttle position). Any change in airspeed or load on the propeller results in a change in propeller pitch.

Fuel System

An 92-gallon usable wet-wing fuel storage system provides fuel for engine operation. The system consists of a 47.25-gallon capacity (46-gallon usable) vented integral fuel tank and a fuel collector/sump in each wing, a three-position selector valve, an electric fuel pump, and an engine-driven fuel pump. Fuel is gravity fed from each tank to the associated collector sumps where the engine-driven fuel pump draws fuel through a filter and selector valve to pressure feed the engine fuel injection system. The electric fuel pump is provided for engine priming and vapor suppression.

Each integral wing fuel tank has a filler cap in the upper surface of each wing for fuel servicing. Access panels in the lower surface of each wing allow access to the associated wet compartment (tank) for inspection and maintenance. Float-type fuel quantity sensors in each wing tank supply fuel level information to the fuel quantity gages. Positive pressure in the tank is maintained through a vent line from each wing tank. Fuel, from each wing tank, gravity feeds through strainers and a flapper valve to the associated collector tank in each wing. Each collector tank/sump incorporates a flush mounted fuel drain and a vent to the associated fuel tank.

The engine-driven fuel pump pulls filtered fuel from the two collector tanks through a three-position (LEFT-RIGHT-OFF) selector valve. The selector valve allows tank selection. From the fuel pump, the fuel is metered to a flow divider, and delivered to the individual cylinders. Excess fuel is returned to the selected tank.

A dual-reading fuel-quantity gage is located in the center console next to the fuel selector in plain view of the pilot. Fuel shutoff and tank selection is positioned nearby for easy access.

Fuel system venting is essential to system operation. Blockage of the system will result in decreasing fuel flow and eventual engine fuel starvation and stoppage. Venting is accomplished independently from each tank by a vent line leading to a NACA-type vent mounted in an access panel underneath the wing near each wing tip.

The airplane may be serviced to a reduced capacity to permit heavier cabin loadings. This is accomplished by filling each tank to a tab visible below the fuel filler, giving a reduced fuel load of 30.0 gallons usable in each tank (60 gallons total usable in all flight conditions).

Drain valves at the system low points allow draining the system for maintenance and for examination of fuel in the system for

Airplane and Systems Description

contamination and grade. The fuel must be sampled prior to each flight. A sampler cup is provided to drain a small amount of fuel from the wing tank drains, the collector tank drains, and the gas-collator drain. If takeoff weight limitations for the next flight permit, the fuel tanks should be filled after each flight to prevent condensation.

Fuel Selector Valve

A fuel selector valve, located at the rear of the center console, provides the following functions:

- LEFT Allows fuel to flow from the left tank
- RIGHT Allows fuel to flow from the right tank
- OFF Cuts off fuel flow from both tanks

The valve is arranged so that to feed off a particular tank the valve should be pointed to the fuel indicator for that tank. To select RIGHT or LEFT, rotate the selector to the desired position. To select Off, first raise the fuel selector knob release and then rotate the knob to OFF.

Fuel Pump Operation

Fuel pump operation and engine prime is controlled through the Fuel Pump switch located adjacent to the fuel selector valve. The PRIME position is momentary and the BOOST position is selectable. A two-speed prime allows the fuel pressure to rapidly achieve proper starting pressure.

An oil pressure-based system is used to control fuel pump operation. The oil pressure/oil temperature sensor provides a signal to the starting circuit to generate a ground for the oil annunciator and the fuel system. This system allows the fuel pump to run at high speed (PRIME) when the engine oil pressure is less than 10 PSI. Whenever the engine oil pressure exceeds 10 PSI, pressing PRIME will have no effect. Selecting BOOST energizes the fuel pump in low-speed mode regardless of oil pressure to deliver a continuous 4-6 psi boost to the fuel flow for vapor suppression in a hot fuel condition.

The fuel pump operates on 28 VDC supplied through the 5-amp FUEL PUMP circuit breaker on MAIN BUS 2.

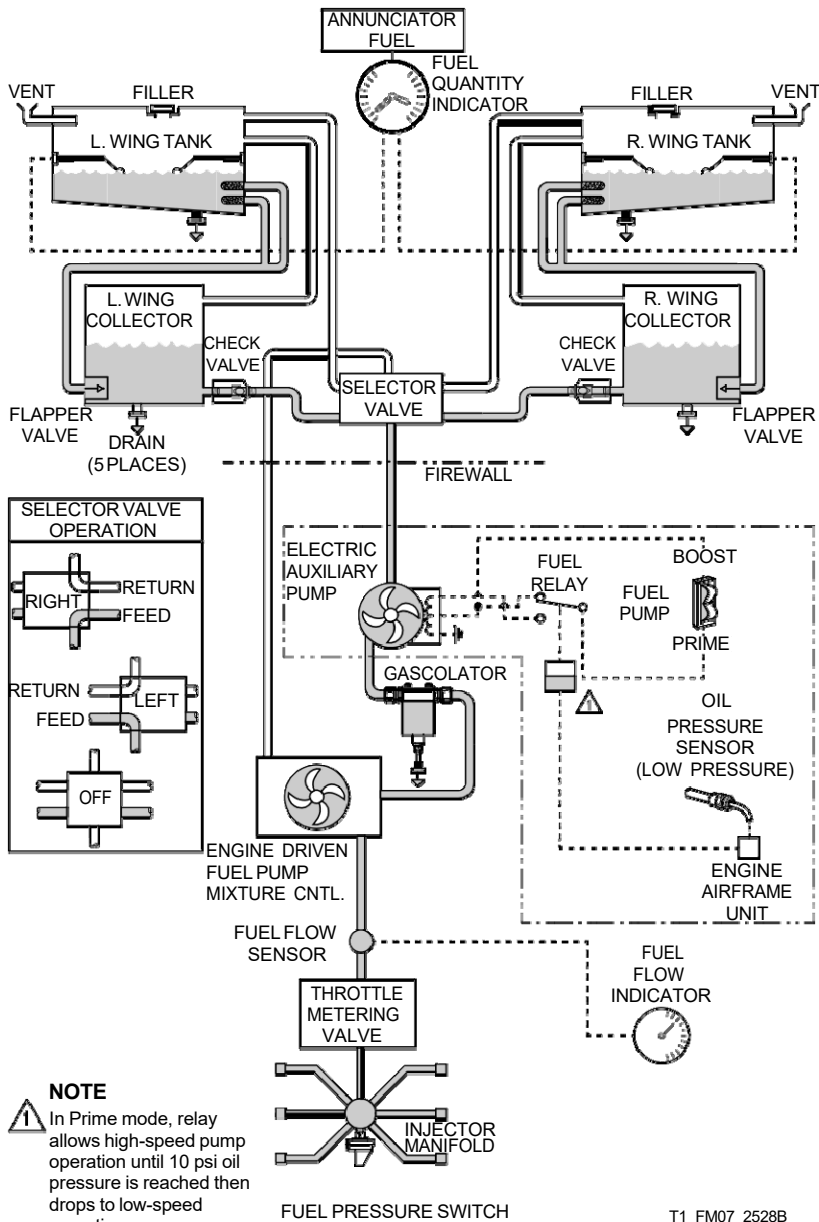

Figure 7-8
Fuel System Schematic

Fuel Indicating

Fuel system information is displayed as analog-style gages and text on the MFD's ENGINE page. When the ENGINE page is not active or in the case of an electronic display failure (backup mode), fuel flow is displayed along the LH edge of the display. Fuel data is acquired by the Engine Airframe Unit which transmits the data to the Engine Indicating System for display as described in the following pages.

• Note •

A "Red X" through any electronic display field indicates that the display field is not receiving valid data and should be considered inoperative.

Fuel System Annunciations

Fuel system health, caution, and warning messages are displayed in color-coded text in the Crew Alerting System (CAS) window located to the right of the Altimeter and Vertical Speed Indicator. In combination with a CAS alert, the affected fuel parameter displayed on the ENGINE page changes to the corresponding color of CAS alert and the annunciation system issues an audio alert.

• Note •

For specific pilot actions in response to Fuel System Annunciations, refer to the Fuel System procedures contained in Section 3 - Emergency Procedures, and Section 3A - Abnormal Procedures.

For additional information on Engine Instrument Markings and Annunciations, refer to Section 2 - Limitations.

For additional information on the System Annunciations and Alerts, refer to the Integrated Avionics System description in this section.

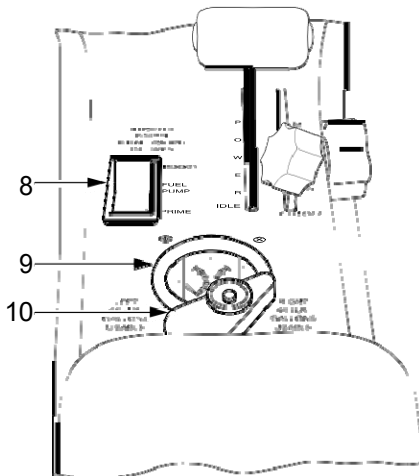
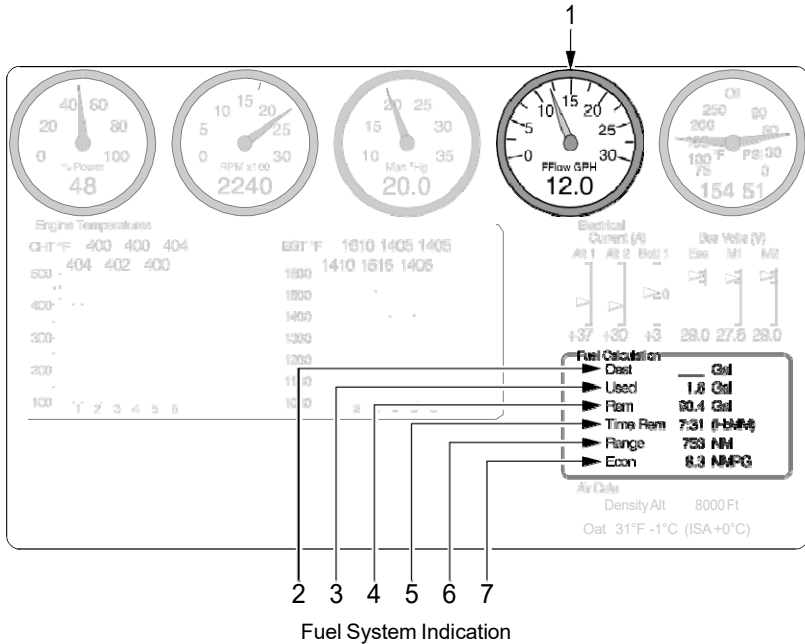

- LEGEND**
1. Fuel Flow
 2. Fuel At Destination (Totalizer)
 3. Fuel Used (Totalizer)
 4. Fuel Remaining (Totalizer)
 5. Time Remaining (Totalizer)
 6. Fuel Range (Totalizer)
 7. Nautical Miles Per Gallon (Totalizer)
 8. Fuel Pump Switch
 9. Fuel Quantity Gage (Float Sensor)
 10. Fuel Selector Valve

Fuel System Controls

T1_FM07_2803

Figure 7-9
Fuel System Controls and Indicating

Airplane and Systems Description***Fuel Quantity Gage***

A dual reading 2 $\frac{1}{4}$ " fuel quantity gage is installed on the console immediately forward of the fuel selector valve. The LEFT pointer indicates left tank fuel quantity and sweeps a scale marked from 0 to 46 U.S. gallons in 5-gallon increments. The RIGHT pointer sweeps an identical scale for the right tank. Each scale is marked with a yellow arc from 0 to 14 U.S. gallons. The indicators are calibrated to read 0 gallons when no usable fuel remains and are internally lighted.

The fuel quantity gage provides output signals to the Engine Airframe Unit based on the float sensor positions in the fuel tanks. The output signals are processed and transmitted to the CAS window for display.

- An white Advisory message is generated when either fuel tank goes below 14 gallons.
- A amber Caution message is generated when both fuel tanks go below 14 gallons.
- A red Warning message is generated when the *fuel totalizer* amount goes below 9 gallons. Note that the Warning message is generated based on the fuel totalizer which is dependent on correct input by the pilot.

28 VDC for fuel quantity system operation is supplied through the 3-amp FUEL QTY circuit breaker on MAIN BUS 1.

• Note •

When the fuel tanks are 1/4 full or less, prolonged uncoordinated flight such as slips or skids can uncover the fuel tank outlets. Therefore, if operating with one fuel tank dry or if operating on LEFT or RIGHT tank when 1/4 full or less, do not allow the airplane to remain in uncoordinated flight for periods in excess of 30 seconds.

Fuel Flow

Fuel Flow is shown in the upper mid right corner of the ENGINE page as both a simulated pressure gage and as a digital value. The gage pointer sweeps a scale range from 0 to 30 Gallons Per Hour (GPH). The fuel flow value is displayed in white numerals below the gage. Fuel flow is measured by a transducer on the right side of the engine in the fuel line between the engine driven fuel pump and distribution block. The fuel flow signal is sent to the Engine Airframe Unit, processed, and transmitted to the Engine Indicating System for display.

Fuel Totalizer and Calculated Information

Fuel totalizer calculations are located in the lower right section of the ENGINE page and are separate and independent of the fuel quantity gage and float sensor system. The fuel totalizer monitors fuel flow and calculates fuel-to-destination, fuel used, fuel remaining, time remaining, fuel range, and nautical miles per gallon. Upon system startup, the fuel totalizer initial fuel screen appears and prompts the user to enter the total fuel on board at start. The option to enter the number of gallons added since last fuel fill and the ability to set fuel to "Full" or to "Tabs" buttons is also available.

Electrical System

The airplane is equipped with a two-alternator, two-battery, 28-volt direct current (VDC) electrical system designed to reduce the risk of electrical system faults. The system provides uninterrupted power for avionics, flight instrumentation, lighting, and other electrically operated and controlled systems during normal operation.

Power Generation

Primary power for the airplane is supplied by a 28-VDC, negative-ground electrical system. The electrical power generation system consists of two alternators controlled by a Master Control Unit (MCU) mounted on the left side of the firewall and two batteries for starting and electrical power storage.

Alternator 1 (ALT 1) is a gear-driven, internally rectified, 100-amp alternator mounted on the right front of the engine. Alternator 2 (ALT 2) is a belt-driven, internally rectified, 70-amp alternator mounted on the front left of the engine. ALT 1 is regulated to 28 volts and ALT 2 is regulated to 28.75 volts. Both alternators are self-exciting and require battery voltage for field excitation in order to start up - for this reason, the batteries should not be turned off in flight.

Storage

Battery 1 (BAT 1) is an aviation grade 12-cell, lead-acid, 24-volt, 10-amp-hour battery mounted on the right firewall. BAT 1 is charged from the Main Distribution Bus 1 in the MCU.

Battery 2 (BAT 2) is composed of two 12-volt, 7-amp-hour, sealed, lead-acid batteries connected in series to provide 24 volts. Both BAT 2 units are located in a vented, acid-resistant container mounted behind the aft cabin bulkhead (FS 222) below the parachute canister. BAT 2 is charged from the circuit breaker panel ESS BUS 1.

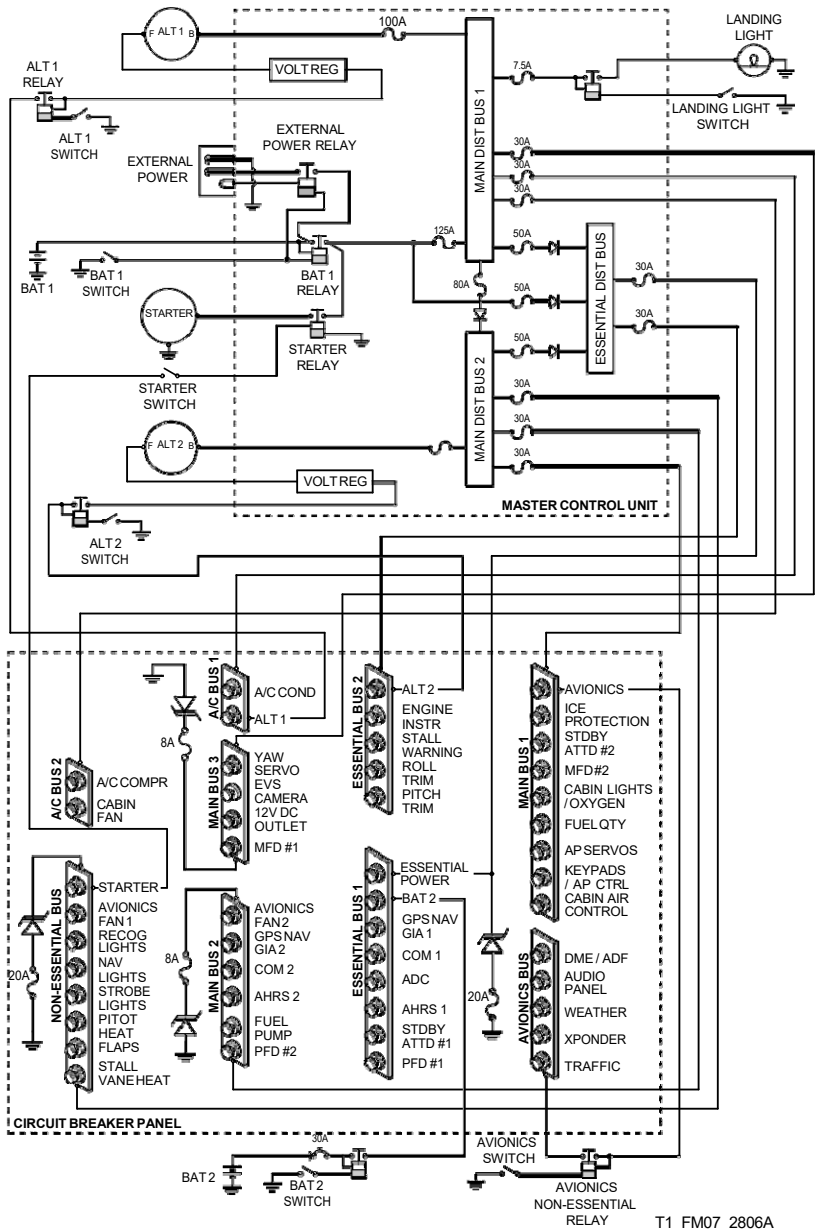

Figure 7-10
Electrical System Schematic

Airplane and Systems Description**Power Distribution**

Power is supplied to the airplane circuits through three distribution buses contained in the MCU; Main Distribution Bus 1, Main Distribution Bus 2, and the Essential Distribution Bus. The three distribution buses power the associated buses on the circuit breaker panel.

Master Control Unit

The Master Control Unit (MCU) is located on the left firewall. The MCU controls ALT 1, ALT 2, starter, landing light, external power, and power generation functions. In addition to ALT 1 and ALT 2 voltage regulation, the MCU also provides external power reverse polarity protection, alternator overvoltage protection, as well as electrical system health annunciations to the Integrated Avionics System. Power is distributed to the airplane circuit panel buses through Main and Essential buses in the MCU. The Main distribution buses are interconnected by an 80-amp fuse and a diode. The diode prevents ALT 2 from feeding the Main Distribution Bus 1. Additionally, since ALT 2 Bus voltage is slightly higher than ALT 1 voltage, bus separation is further assured.

Essential Distribution Bus

The Essential Distribution Bus is fed by both Main Distribution Bus 1 and Main Distribution Bus 2 in the MCU through two 50-amp fuses. The Essential Bus powers two circuit breaker buses through 30-amp fuses located in the MCU;

- ESS BUS 1,
- ESS BUS 2.

Main Distribution Bus 1

The output from ALT 1 is connected to the Main Distribution Bus 1 in the MCU through a 100-amp fuse. Main Distribution Bus 1 directly powers the Landing Light through a 7.5-amp fuse and three circuit breaker buses through 30-amp fuses located in the MCU;

- A/C BUS 1,
- A/C BUS 2,
- MAIN BUS 3.

Main Distribution Bus 2

The output from ALT 2 is connected to the Main Distribution Bus 2 in the MCU through an 80-amp fuse. Main Distribution Bus 2 powers three circuit breaker buses through 30-amp fuses located in the MCU;

- NON ESS BUS,
- MAIN BUS 1,
- MAIN BUS 2.

Electrical System Protection

Circuit Breakers, Fuses and Voltage Suppressors

Individual electrical circuits connected to the Main, Essential, and Non-Essential Buses in the airplane are protected by re-settable circuit breakers mounted in the circuit breaker panel on the left side of the center console. Loads on circuit breaker panel buses are shed by pulling the individual circuit breakers.

Transient Voltage Suppressors

Transient Voltage Suppressors (TVS) are installed in key areas of the electrical system to protect the system from lightning strikes. During lightning strikes, enormous energy spikes can be induced within the airplane electrical system. In the absence of any transient protection, this unwanted energy would typically be dissipated in the form of high-voltage discharge across the avionics and electrical systems of the airplane. By adding a high power TVS at key power entry points on the electrical busses, unwanted energy from electrical transients is allowed to dissipate through a semi-conducting pathway to ground.

• Caution •

If smoke and/or fumes are detected in the cabin and it is suspected that this event was caused by a TVS failure, the operator should confirm that there is no fire and perform the Smoke and Fume Elimination checklist.

Essential Buses

The circuit breaker panel ESS BUS 1 and ESS BUS 2 are powered directly by ALT 1 and ALT 2 from the MCU Essential Distribution Bus through 30-amp fuses inside the MCU and also by BAT 2 through the 20-amp BAT 2 circuit breaker.

In the event of ALT 1 or ALT 2 failure, the Essential Buses in the circuit breaker panel will be powered by the remaining alternator through the

Airplane and Systems Description

Main Distribution Bus 1 or Main Distribution Bus 2 in the MCU. In the case of both alternators failing, BAT 1 is connected directly to the Essential Distribution Bus in the MCU and will power ESS BUS 1 and ESS BUS 2. In the event of both alternators and BAT 1 failing, BAT 2 is connected directly to ESS BUS 1.

Main Buses

The circuit breaker panel MAIN BUS 1 and MAIN BUS 2 are powered by ALT 2 from the MCU Main Distribution Bus 2 and - in the event of ALT 2 failure - by ALT 1 and BAT 1 from the Main Distribution Bus 2 via the diode interconnecting the MCU distribution buses through 30-amp fuses inside the MCU.

The 10-amp AVIONICS circuit breaker on MAIN BUS 1, controlled through the AVIONICS master switch on the bolster switch panel, powers all loads on the AVIONICS BUS.

The circuit breaker panel MAIN BUS 3 is powered by ALT 1 and BAT 1 from the MCU Main Distribution Bus 1 through a 30-amp fuse inside the MCU. In the event of ALT 1 failure, BAT 1 will power MAIN BUS 3. ALT 2 is prevented from powering MAIN BUS 3 by the isolation diode interconnecting the MCU distribution buses 1 and 2.

Non-Essential Buses

The circuit breaker panel NON ESS BUS is powered by ALT 2 from the MCU Main Distribution Bus 2 and - in the event of ALT 2 failure - by ALT 1 and BAT 1 from the Main Distribution Bus 2 via the diode interconnecting the MCU distribution buses through 30-amp fuses inside the MCU. The Avionics Non-Essential Bus is powered through the 10-amp AVIONICS circuit breaker on MAIN BUS 1 and is discussed above.

The circuit breaker panel A/C BUS 1 and A/C BUS 2, is powered by ALT 1 and BAT 1 from the MCU Main Distribution Bus 1 through a 30-amp fuse inside the MCU. In the event of ALT 1 failure, BAT 1 will power A/C BUS 1 and A/C BUS 2. ALT 2 is prevented from powering A/C BUS 1 and A/C BUS 2 by the isolation diode interconnecting the MCU distribution buses 1 and 2.

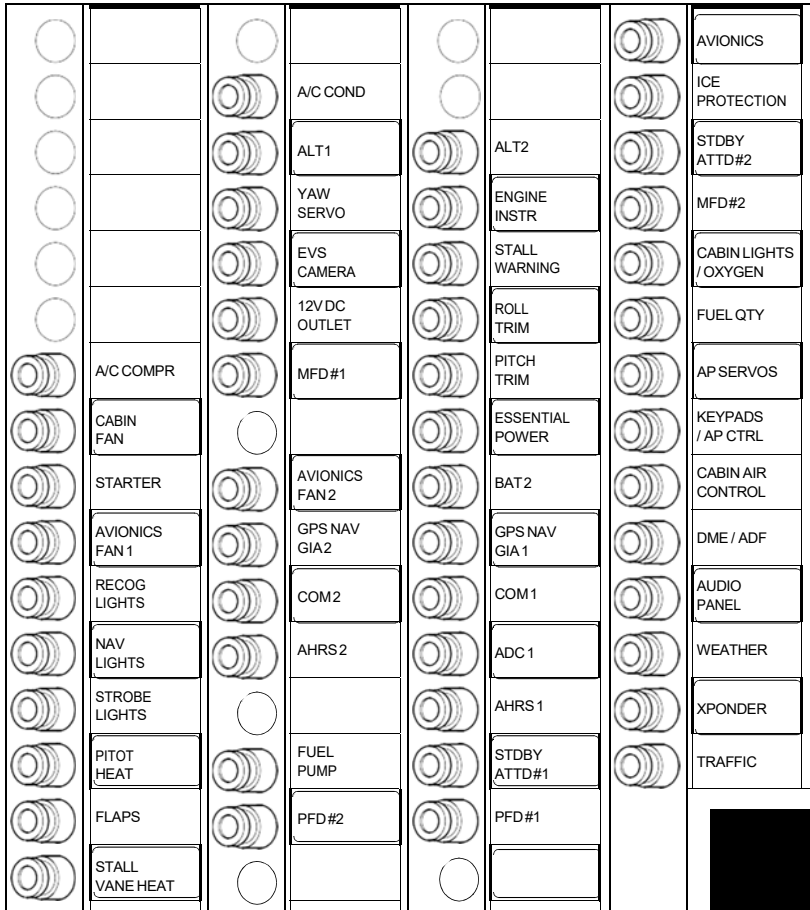

T1_FM03A_2949A

Figure 7-11
Circuit Breaker Panel

Electrical System Control

The rocker type electrical system MASTER switches are 'on' in the up position and 'off' in the down position. The switches, labeled BAT 2, BAT 1, ALT 1, ALT 2 are located in the bolster switch panel immediately below the instrument panel. These switches, along with the AVIONICS power switch, control all electrical power to the airplane.

Battery Switches

The BAT 1 and BAT 2 switches control the respective battery. Setting the BAT 1 switch 'on' energizes a relay connecting BAT 1 to the MCU Distribution Buses (also energizing the circuit breaker panel buses) and the open contacts of the starter relay. Setting the BAT 2 switch 'on' energizes a relay connecting BAT 2 to the circuit breaker panel ESS BUS 1. Normally, for flight operations, all master switches will be 'on'. However, the BAT 1 and BAT 2 switches can be turned 'on' separately to check equipment while on the ground. Setting only the BAT 2 switch 'on' will energize those systems connected to the circuit breaker panel's ESS BUS 1 and ESS BUS 2. If any system on the other buses is energized, a failure of the Distribution Bus interconnect isolation diode is indicated. When the BAT 1 switch is set to 'on,' the remaining systems will be energized. To check or use non-essential avionics equipment or radios while on the ground, the AVIONICS power switch must also be turned on.

Alternator Switches

The ALT 1 and ALT 2 switches control field power to the respective alternator. For ALT 1 to start, the BAT 1 switch must be 'on'. Setting the ALT 1 switch 'on' energizes a relay allowing 28 VDC from the 5 amp ALT 1 circuit breaker on A/C BUS 1 to be applied to a voltage regulator for ALT 1. For ALT 2 to start, either the BAT 1 switch or the BAT 2 switch must be 'on.' Setting the ALT 2 switch 'on' energizes a relay allowing 28 VDC from the 5 amp ALT 2 circuit breaker on ESS BUS 2 to be applied to voltage regulator for ALT 2. Positioning either ALT switch to the OFF position removes the affected alternator from the electrical system.

• Caution •

Continued operation with the alternators switched off will reduce battery power enough to open the battery relay, remove power from the alternator field, and prevent alternator restart.

Avionics Power Switch

A rocker switch, labeled AVIONICS, controls electrical power from the circuit breaker panel (MAIN BUS 1) to the Avionics Bus. The switch is located next to the ALT and BAT Master switches. Typically, the switch is used to energize or de-energize all non-essential avionics on the AVIONICS bus simultaneously. With the switch in the OFF position, no electrical power will be applied to the non-essential avionics equipment, regardless of the position of the MASTER switch or the individual equipment switches. For normal operations, the AVIONICS switch should be placed in the OFF position prior to activating the MASTER switches, starting the engine, or applying an external power source.

Ground Service Receptacle

A ground service receptacle is located just aft of the cowl on the left side of the airplane. This receptacle is installed to permit the use of an external power source for cold weather starting and maintenance procedures requiring reliable power for an extended period. The external power source must be regulated to 28 VDC. The external power control contactor is wired through the BAT 1 MASTER switch so that the BAT 1 switch must be 'on' to apply external power.

Refer to Section 8, Ground Handling, Servicing, and Maintenance, for use of external power and special precautions to be followed.

Electrical Indicating

Electrical system information is displayed as bar graphs and text on the MFD's ENGINE page. When the ENGINE page is not active or in the case of an electronic display failure (backup mode), Battery 1 ampere output and Essential Bus voltage output are displayed along the LH edge of the display. Electrical data is acquired by the Engine Airframe Unit which transmits the data to the Engine Indicating System for display as described in the following pages.

• Note •

A "Red X" through any electronic display field indicates that the display field is not receiving valid data and should be considered inoperative.

Electrical System Annunciations

Electrical system health, caution, and warning messages are displayed in color-coded text in the Crew Alerting System (CAS) window located to the right of the Altimeter and Vertical Speed Indicator. In combination with a CAS alert, the affected electrical parameter displayed on the ENGINE page changes to the corresponding color of CAS alert and the annunciation system issues an audio alert.

• Note •

For specific pilot actions in response to Electrical System Annunciations, refer to the Electrical System procedures contained in Section 3 - Emergency Procedures, and Section 3A - Abnormal Procedures.

For additional information on Engine Instrument Markings and Annunciations, refer to Section 2 - Limitations.

For additional information on the System Annunciations and Alerts, refer to the Integrated Avionics System description in this section.

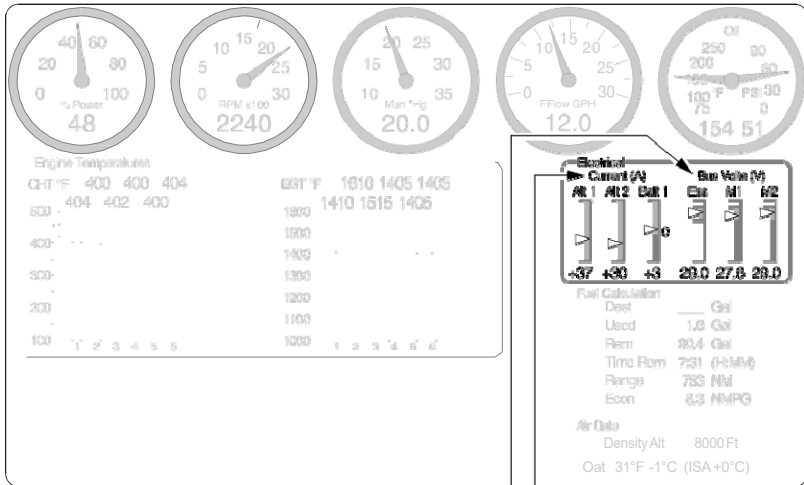

1 2

Electrical System Indication

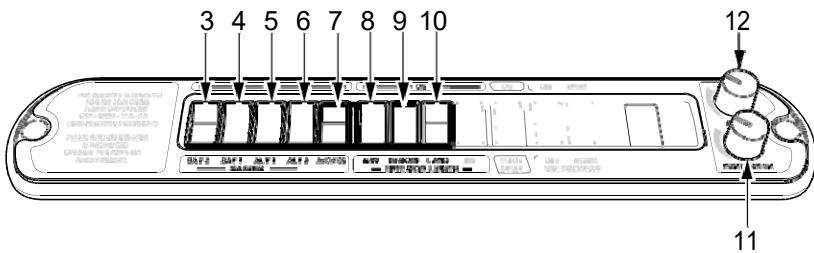

Electrical and Lighting Controls

LEGEND

- | | |
|---------------------------------|-----------------------|
| 1. Essential & Main Bus Voltage | 7. Avionics |
| 2. Alternator & Battery Current | 8. Navigation |
| 3. Battery 2 | 9. Strobe |
| 4. Battery 1 | 10. Landing Light |
| 5. Alternator 1 | 11. Instrument Dimmer |
| 6. Alternator 2 | 12. Panel Dimmer |

T1_FM07_2811A

Figure 7-12
Electrical / Lighting Controls and Indicating

Lighting Systems

Exterior Lighting

The airplane is equipped with wing tip navigation lights with integral anti-collision strobe lights and recognition Lights. The landing light is located in the lower cowl.

Navigation Lights

The airplane is equipped with standard wing tip navigation lights. The lights are controlled through the NAV light switch on the instrument panel bolster.

28 VDC for navigation light operation is supplied through the 5-amp NAV LIGHTS circuit breaker on the NON ESS BUS.

Strobe Light

Anti-collision strobe lights are installed integral with the standard navigation lights. Each strobe is flashed by a separate power supply. The strobe power supplies are controlled through the STROBE light switch on the instrument panel bolster.

28 VDC for strobe light and control circuits is supplied through the 5-amp STROBE LIGHTS circuit breaker on the NON ESS BUS.

Landing Light

A High Intensity Discharge (HID) landing light is mounted in the lower engine cowl. The landing light is controlled through the LAND light switch on the instrument panel bolster.

Setting the LAND light switch 'on' energizes the landing light control relay in the Master Control Unit (MCU) completing a 28 VDC circuit from the airplane Main Distribution Bus 1 to the light's ballast located on the firewall. The ballast provides boosted voltage to illuminate the HID lamp.

A 7.5-amp fuse on the Main Distribution Bus 1 in the MCU protects the circuit.

Recognition Lights

The airplane is equipped with recognition lights on the leading edge of the wing tips. The lights are controlled through the landing light switch on the instrument panel bolster.

28 VDC for recognition light operation is supplied through the 5-amp RECOG LIGHTS circuit breaker on the NON ESS BUS.

Interior Lighting

Interior lighting for the airplane consists of separately controlled incandescent overhead lights for general cabin lighting, individual lights for the pilots and passengers, and dimmable panel floodlights. The flight instrumentation and avionics equipment lights are dimmable.

Instrument Lights

Instrument lighting for the airplane includes: Primary Flight and Multifunction Display backlighting and bezel, bolster switch panel, audio panel keys, FMS keyboard, and optionally installed GMC 705 AFCS Control Unit, incandescent lights in the standby instrument bezels, key backlighting and status lighting for the flap and Environmental Control System (ECS) control panels. Associated lighting is adjustable through the INSTRUMENT dimmer control on the instrument panel bolster. The dimmer is OFF when rotated fully counterclockwise, all systems revert to daytime lighting in this position (not full DIM).

In daytime lighting (knob OFF/full counterclockwise):

- Standby instruments, all Avionics system keypads and the bolster switch panel are unlit
- MFD and PFD screen illumination is controlled by automatic photocell (providing full brightness in high light conditions, only slightly reduced by darkness)
- ECS and control panels are backlight and their status lights at maximum intensity

With active dimming (knob moved clockwise), the full bright position (full clockwise) applies maximum illumination to keys and switches, to standby instruments and to status lights, but the PFD/MFD screen illumination is at a substantially reduced level (levels still appropriate for night flight). Maximum screen illumination (appropriate for daytime use) is with the dimmer OFF/full counterclockwise.

The instrument light circuits operate on 28 VDC supplied through the 5-amp CABIN LIGHTS circuit breaker on MAIN BUS.

Airplane and Systems Description***Panel Flood Lights***

A string of red LEDs mounted under the instrument panel glare-shield provide flood lighting for the instrument panel. The lights are controlled through the PANEL dimmer control on the instrument panel bolster.

The panel lights operate on 28 VDC supplied through the 5-amp CABIN LIGHTS circuit breaker on MAIN BUS 1.

Reading Lights

Individual eyeball-type reading lights are installed in the headliner above each passenger position. Each light is aimed by positioning the lens in the socket and is controlled by a push-button switch located next to the light. The pilot and copilot reading lights are also dimmable through the PANEL lights control on the instrument panel bolster. The reading lights are powered by 28 VDC supplied through the 5-amp CABIN LIGHTS circuit breaker on MAIN BUS 1.

Overhead Dome Light

General cabin lighting is provided by a dome light located in the headliner at the approximate center of the cabin. The dome light is controlled through the OVERHEAD light control on the instrument panel bolster or by the switch next to the light assembly on the ceiling of the airplane. On airplane with OVERHEAD light control on the instrument panel bolster, rotating the knob clockwise from the off position will illuminate the light and control its intensity. The dome light is powered by 28 VDC supplied through the 5-amp CABIN LIGHTS circuit breaker on MAIN BUS 1.

Environmental System

• Note •

To facilitate faster cabin cooling, prior to engine start leave the cabin doors open for a short time to allow hot air to escape.

Standard cabin heating and ventilation is accomplished by supplying conditioned air from the heat exchanger for heating and windshield defrost and fresh outside air for ventilation. The environmental system consists of a fresh air inlet in the lower RH cowl, a heat exchanger around the RH engine exhaust muffler, an air mixing chamber, air ducting for distribution, a distribution manifold, a windshield diffuser, crew and passenger air vents, and associated plumbing, controls, actuators, wiring for system flow-selection and temperature control.

An optional 3-speed blower fan is available to supplement airflow when ram air may be inadequate such as during ground operation.

28 VDC for Environmental System Control Panel operation is supplied through the 2-amp CABIN AIR CONTROL breaker on MAIN BUS 1.

The optional Blower Fan is powered by 28 VDC supplied through a 15-amp CABIN FAN breaker on A/C BUS 2.

Serials with Optional Air Condition System;

The Air Conditioning System is designed to cool the cabin to desired temperature settings and maintain comfortable humidity levels. The system consists of an engine driven compressor, condenser assembly, and evaporator assembly.

28 VDC for Air Conditioner Condenser operation is supplied through the 15-amp A/C COND breaker on A/C BUS 1.

28 VDC for Air Conditioner Compressor operation is supplied through the 5-amp A/C COMPR breaker on A/C BUS 2.

The airplane engine must be running for the air conditioner to operate.

Distribution

Ventilation and cooling is provided by ducting fresh air from a NACA inlet on the RH lower cowl to the mixing chamber located on the lower RH portion of the firewall. Depending on operating mode and temperature selection, the air in the mixing chamber is ducted directly into the distribution system or, if in optional air conditioning mode, is further cooled as it passes through the evaporator assembly located under the front passenger seat.

Heating is accomplished by mixing ventilation air from the fresh air inlet with heated air provided by the heat exchanger in the mixing chamber on the firewall. From the mixing chamber - which also controls airflow into the cabin compartment - the conditioned air is forced by ram air pressure or by blower fan into a distribution manifold mounted to the center, aft side of the firewall. The distribution manifold uses butterfly valves to control airflow to the floor and defrost vents. Airflow is ducted directly to all panel air vents.

Crew panel air vents are located inboard on the RH and LH bolster panels and on the outboard section of the instrument panel. The crew floor air vents are mounted to the bottom of each kick plate. The passenger panel air vents are chest high outlets mounted in the armrests integral to the LH and RH cabin wall trim panels. The passenger floor air vents are mounted to the bottom portion of the LH and RH cabin wall trim panels. The windshield diffuser, located in the glare-shield assembly, directs conditioned air to the base of the windshield.

Heating

Ram air from the NACA inlet flows through the upper cowl and is ducted to the heat exchanger. The heated air is then routed to the hot air valve, mounted to the forward side of the firewall, which controls entry of hot air into the cabin distribution system. When the valve is open, the air flows into the cabin mixing chamber. When the valve is closed, the heated air exits into the engine compartment and is exhausted overboard with the engine cooling airflow. Cabin heat is regulated by controlling the volume of hot air admitted into the distribution system's air mixing chamber. The proportion of heated air to fresh air is accomplished using the temperature selector mounted on the RH instrument panel.

Cooling

Standard cabin cooling is provided by ram air admitted through the NACA inlet on the RH cowl to the fresh air valve, mounted to the forward side of the firewall. When the fresh air valve is open, the air flows into the cabin mixing chamber. When the fresh air valve is closed, the cooled air exits into the engine compartment and is exhausted overboard with the engine cooling airflow.

In Air Conditioning mode (optional), R134A refrigerant enters the engine mounted compressor as a vapor and is pressurized until the heat-laden vapor reaches a point much hotter than the outside air. The compressor then pumps the vapor to the condenser where it cools, changes to a liquid, and passes to the receiver-drier. The receiver-drier's function is to filter, remove moisture, and ensure a steady flow of liquid refrigerant into the evaporator through the expansion valve - a temperature-controlled metering valve which regulates the flow of liquid refrigerant to the evaporator. Inside the evaporator, the liquid refrigerant changes state to a gas and in doing so, absorbs heat. The evaporator then absorbs the heat from the air passing over the coils and the moisture from the air condenses and is drained overboard through the belly of the airplane. From the evaporator, the refrigerant vapor returns to the compressor where the cycle is repeated. During normal air conditioning operation, ram air from the fresh air intake flows into the evaporator assembly, is cooled as it passes through the evaporator coils, and is then ducted forward to the distribution manifold.

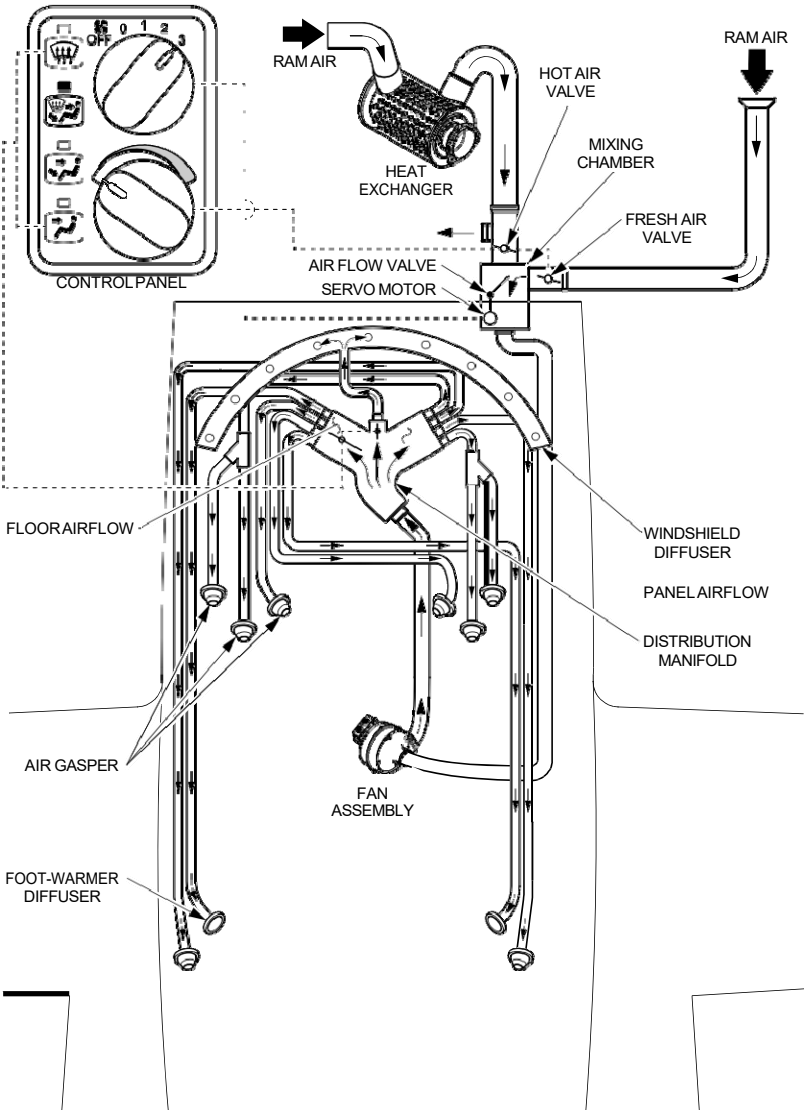

NOTE: Illustration depicts maximum cabin cooling airflows and selector settings with optional Fan installation.

T1_FM07_2782

Figure 7-13
Standard Environmental System

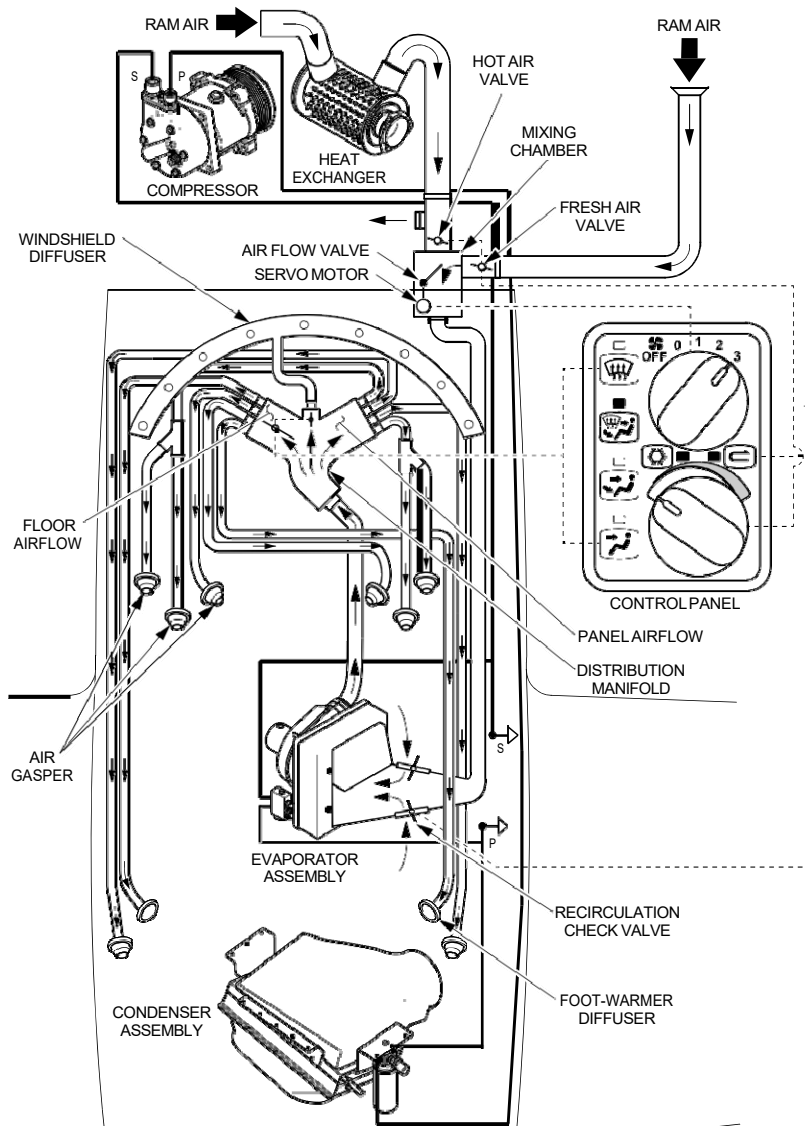

NOTE: Illustration depicts maximum cabin cooling airflows and selector settings while on ground or warm outside air temperatures.

T1_FM07_2783

Figure 7-14
Optional Air Conditioning System

Airflow Selection

The airflow selector on the system control panel regulates the volume of airflow allowed into the cabin distribution system. When the airflow selector is moved past the OFF position an electro-mechanical linkage actuates a valve in the mixing chamber on the forward firewall to the full open position. The air is then distributed by either ram air or blower fan to the distribution manifold mounted to the center, aft side of the firewall. The airflow system modes are as follows: OFF (ram air), 1 (low fan), 2 (medium fan), and 3 (high fan).

Vent Selection

Air from the distribution manifold is proportioned and directed to passengers and/or the windshield by pressing the cabin vent selector buttons which electrically actuate butterfly valves at the entrances to the windshield diffuser and the cabin floor ducting.

When the Temperature Selector is in the blue “cool” zone, there is continuous airflow to the panel and armrest eyeball outlets. Each occupant can control the flow rate from 'off' to maximum by rotating the nozzle.

When the Panel selector button is pushed, both butterfly valves are closed providing maximum airflow to the instrument panel and armrest eyeball outlets.

Pressing the Panel-Foot selector button opens the cabin floor butterfly valve allowing airflow to the rear seat foot warmer diffusers and the front seat outlets mounted to the underside of each kickplate.

Selecting Panel-Foot-Windshield button opens the windshield diffuser butterfly valve which permits shared airflow to the defrosting mechanism and cabin floor outlets.

When the Windshield selector button is pushed the cabin floor butterfly valve is closed providing maximum airflow to the windshield diffuser.

Temperature Selection

The temperature selector is electrically linked to the hot and cold air valves. Rotating the selector simultaneously opens and closes the two valves, permitting hot and cold air to mix and enter the distribution system. Rotating the selector clockwise, permits warmer air to enter the system - counterclockwise, cooler air.

On airplane with the optional Air Conditioning System installed, when the air conditioning button (snowflake) is pushed, the valve on the firewall completely closes and the air-conditioner is activated. When recirculation button is pushed, the fresh air valve completely closes and cabin air is recirculated to provide for maximum air conditioning operation. When the air conditioning system is on and the temperature selector is rotated to the full cool position, recirculating mode can be activated to provide maximum cabin cooling. Air conditioning or recirculating mode is not available when the airflow fan selector is in the "0" position. Recirculating mode is not available unless the air conditioning system is operating.

Rotating the selector controls the volume of airflow allowed into the cabin distribution system through use of an electro-mechanical linkage to a butterfly (hot air) valve in the mixing chamber on the forward firewall. When the airflow selector fan speed is moved to the 1, 2, or 3 position the electro-mechanical linkage actuates the hot air valve to the full open position and the 3-speed blower fan is turned on.

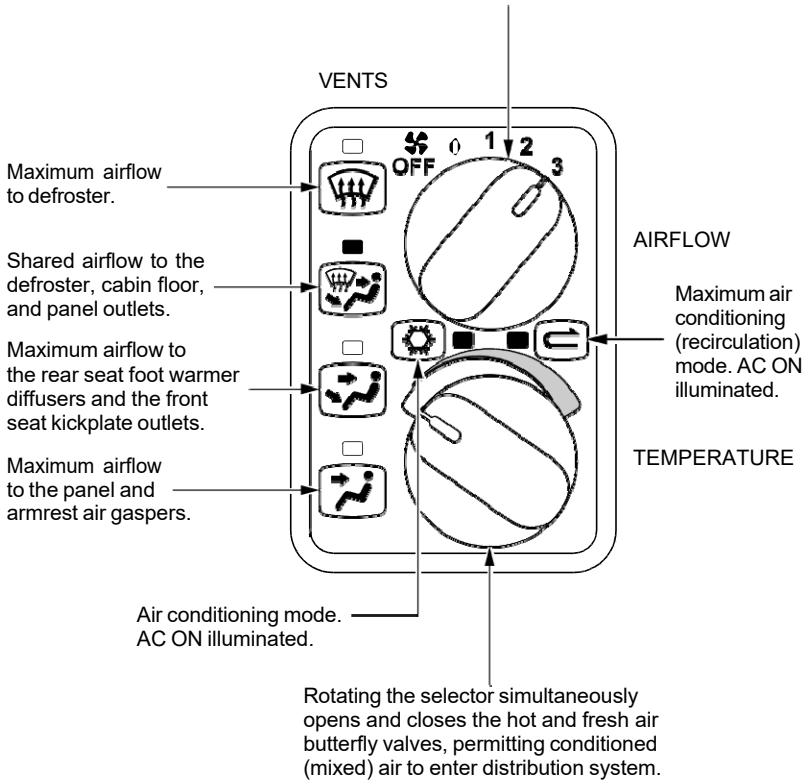

NOTE: Illustration depicts settings for Emergency Procedures Smoke and Fume Elimination.
If source of smoke and fume is firewall forward, turn Airflow Selector OFF.

SR20_FM09_3362

Figure 7-15
Environmental System Operation

Stall Warning System

The airplane is equipped with an electro-pneumatic stall warning system to provide audible warning of an approach to aerodynamic stall. The system consists of an inlet in the leading edge of the right wing, a pressure switch and associated plumbing, a piezo-ceramic horn behind the instrument panel or, the avionics system aural warning system.

As the airplane approaches a stall, the low pressure on the upper surface of the wings moves forward around the leading edge of the wings. As the low-pressure area passes over the stall warning inlet, a slight negative pressure is sensed by the pressure switch. The pressure switch then provides a signal to cause the warning horn to sound, the red STALL warning CAS annunciation to illuminate, and, if engaged, the autopilot system to disconnect.

The warning sounds at approximately 5 knots above stall with full flaps and power off in wings level flight and at slightly greater margins in turning and accelerated flight.

The system operates on 28 VDC supplied though the 2-amp STALL WARNING circuit breaker on the ESS BUS 2.

Preflight Check

With battery power on, the stall warning system preflight check is accomplished as follows:

Stall warning system preflight check:

1. Use small suction cup and apply suction. A sound from the warning horn will confirm that the system is operative.

Pitot-Static System

The Pitot-Static system consists of a single heated Pitot tube mounted on the left wing and dual static ports mounted in the fuselage. The Pitot heat is pilot controlled through a panel-mounted switch. An internally mounted alternate static pressure source provides backup static pressure should that the primary static source becomes blocked. Water traps with drains, under the floor in the cabin, are installed at each Pitot and static line low point to collect any moisture that enters the system. The traps should be drained at the annual inspection and when water in the system is known or suspected.

Pitot Heat Switch

The heated Pitot system consists of a heating element in the Pitot tube, a rocker switch labeled PITOT HEAT, and associated wiring. The switch and circuit breaker are located on the left side of the switch and control panel. When the Pitot heat switch is turned on, the element in the Pitot tube is heated electrically to maintain proper operation in possible icing conditions. The Pitot heat system operates on 28 VDC supplied through the 7.5-amp PITOT HEAT circuit breaker on the NON-ESSENTIAL BUS.

Pitot Heat Annunciation

Illumination of the PITOT HEAT FAIL Caution indicates that the Pitot Heat switch is ON and the Pitot heater is not receiving electrical current. Illumination of PITOT HEAT REQD Caution indicates the system detects OAT is less than 41°F (5°C) and Pitot Heat Switch is OFF. A current sensor on the Pitot heater power supply wire provides current sensing.

Alternate Static Source

An alternate static pressure source valve is installed on the switch and control panel to the right of the pilot's leg. This valve supplies static pressure from inside the cabin instead of the external static port. If erroneous instrument readings are suspected due to water or ice in the pressure line going to the standard external static pressure source, the alternate static source valve should be turned on. Pressures within the cabin will vary with open heater/vents. Whenever the alternate static pressure source is selected, refer to Section 5 for airspeed calibration and altitude corrections to be applied.

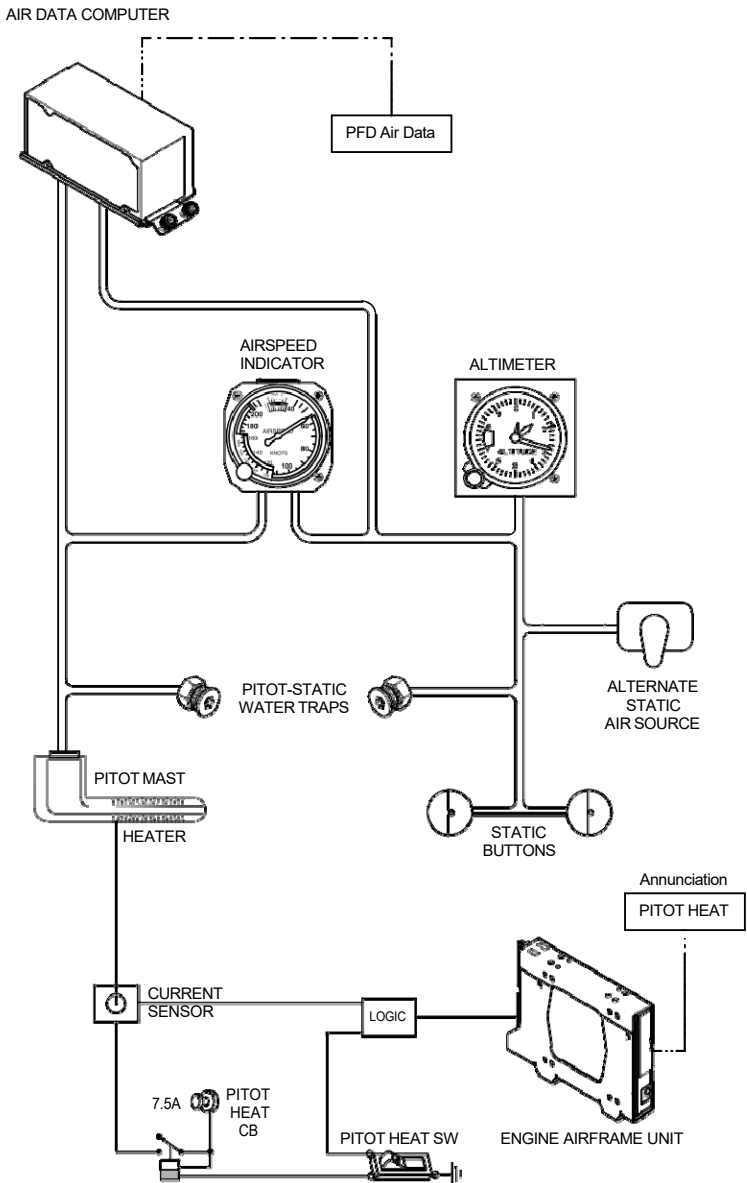

T1_FM07_2794A

Figure 7-16
Pitot-Static System

Avionics

Integrated Avionics System

The Integrated Avionics System provides advanced cockpit functionality and improved situational awareness through the use of fully integrated flight, engine, communication, navigation and monitoring equipment. The system consists of the following components:

- GDU Primary Flight Display (PFD)
- GDU Multifunction Display (MFD)
- GCU 478 Flight Management System Keyboard
- GRS 77 Attitude and Heading Reference System
- GDC 74H Air Data Computer
- GIA 63W Integrated Avionics Units
- GEA 71 Engine Airframe Unit
- GTX 33D Mode A, C Transponder
- GMA 347 Audio Panel with Integrated Marker Beacon Receiver
- GFC 700 3-Axis Autopilot and GMC 705 Controller (Optional)
- GTX 33ES Mode S Transponder (Optional)
- GDL 69/69A XM Satellite Weather/Radio Receiver (Optional)
 - GRT 10 XM Radio Remote Transceiver (Optional)
 - GRC 10 XM Radio Remote Control (Optional)
- S-Tec System 55X Autopilot with Optional Flight Director
- S-Tec System 55SR (Optional)
- Traffic Advisory System (Optional)
- Weather Information System (Optional)
- Bendix/King KR 87 Automatic Direction Finder (Optional)
- Bendix/King KN 63 Distance Measuring Equipment (Optional)
- Synthetic Vision System (Optional)
- Max Viz Enhanced Vision System (Optional)

Refer to the Integrated Avionics System Pilot's Guide for a detailed description of the system and its operating modes.

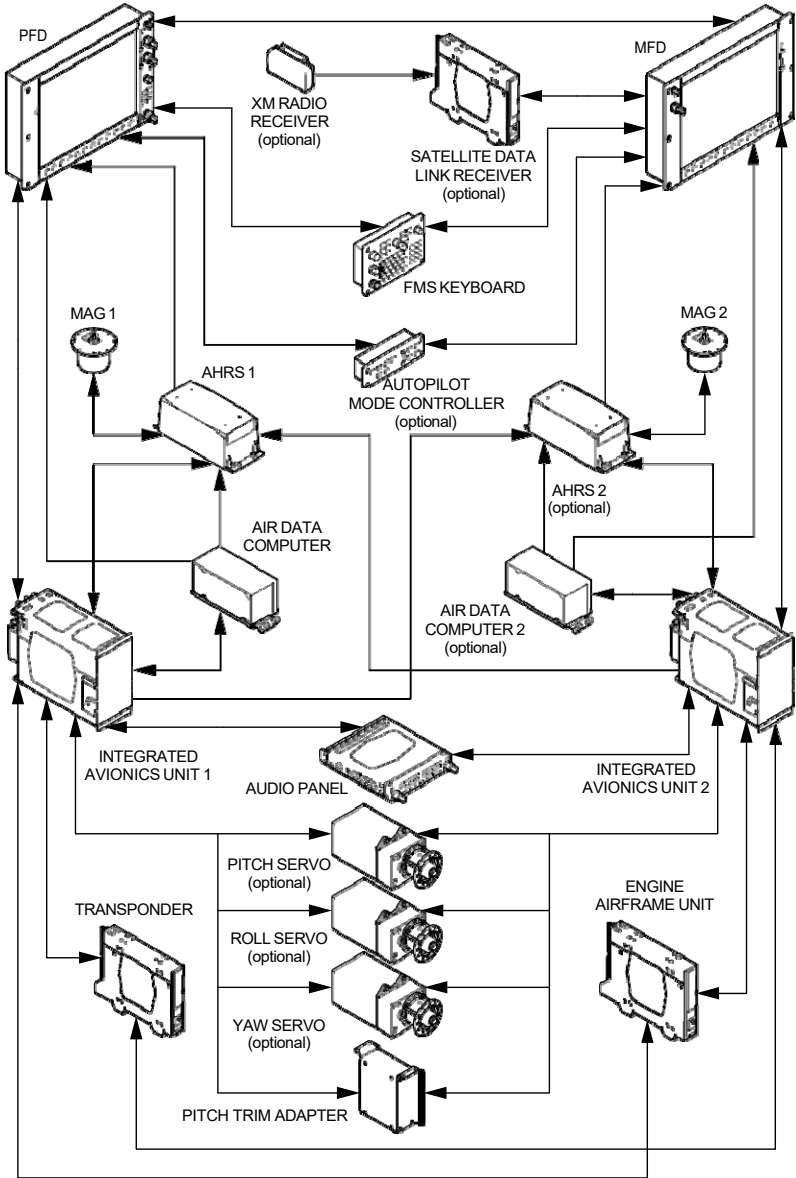

T1_FM07_2915A

Figure 7-17
Integrated Avionics System Schematic

Airplane and Systems Description***GDU Primary Flight Display***

The Primary Flight Display, located directly in front of the pilot, is intended to be the primary display of flight parameter information (attitude, airspeed, heading, and altitude) during normal operations. The PFD accepts data from a variety of sources, including the MFD and the Integrated Avionics Units through a high-speed data bus connection. In conjunction with Flight Management System Keyboard, the PFD also controls and displays all communication and navigation frequencies as well as displaying warning/status annunciations on airplane systems. During engine start, reversionary operation (MFD failure), or when the DISPLAY BACKUP switch is selected, engine system information is displayed on the PFD.

Redundant power sources provide 28 VDC for PFD operation. Power is supplied through the 5-amp PFD 1 circuit breaker on the ESS BUS 1 and the 5-amp PFD 2 circuit breaker on MAIN BUS 2. Either circuit is capable of powering the PFD. System start-up is automatic once power is applied. Power-on default brightness is determined by ambient lighting and is user adjustable. Typical alignment time is 60 seconds from battery turn on.

Display Backup Mode

In the event of a detected display failure, the Integrated Avionics System automatically switches to Display Backup Mode. In Display Backup Mode, all essential flight information from the PFD is presented on the remaining display in the same format as in normal operating mode with the addition of the Engine Indicating System. The change to backup is completely automated and no pilot action is required. However, if the system fails to detect a display problem, Display Backup Mode may be manually activated by pressing the red DISPLAY BACKUP Button. Pressing this button again deactivates Display Backup Mode.

GDU Multifunction Display

The Multifunction Display, located above the center console, depicts navigation, terrain, lightning, traffic data, NAV/COM frequencies, and annunciation information. All engine data is displayed on a dedicated ENGINE page. When the ENGINE page is not shown, all essential engine information is shown on an engine strip at the edge of the display.

Redundant power sources provide 28 VDC for MFD operation. Power is supplied through the 5-amp MFD 1 circuit breaker on the MAIN BUS

3 and the 5-amp MFD 2 circuit breaker on MAIN BUS 1. Either circuit is capable of powering the MFD. System start-up is automatic once power is applied. Power-on default brightness is determined by ambient lighting and is user adjustable.

GCU 478 Flight Management System Keyboard

The Flight Management System Keyboard is found on the upper section of the center console and is the primary interface for avionics system data entry, PFD/MFD operation, NAV/COM tuning, and heading, course and altitude selection.

28 VDC for Flight Management System Keyboard operation is supplied through the 5-amp KEYPADS / AP CTRL circuit breaker on MAIN BUS 1.

GRS 77 Attitude and Heading Reference System (AHRS)

The Attitude and Heading Reference System (AHRS) unit(s), mounted behind the PFD, provide airplane attitude and heading information to both the PFD and the primary Air Data Computer. The AHRS units(s) contain advanced sensors (including accelerometers and rate sensors) and interfaces with the; primary Magnetometer to obtain magnetic field information, the Air Data Computer to obtain air data, and both Integrated Avionics Units to obtain GPS information.

28 VDC for AHRS 1 operation is supplied through the 5-amp AHRS 1 circuit breaker on the ESS BUS 1. If option installed, 28 VDC for AHRS 2 operation is supplied through the 5-amp AHRS 2 / ADC 2 circuit breaker on the MAIN BUS 2.

GDC 74H Air Data Computer (ADC)

The Air Data Computer(s), mounted behind the instrument panel to the right of the MFD, process data from the Pitot/Static system and outside air temperature (OAT) sensor(s). This unit(s) provide pressure altitude, airspeed, vertical speed and OAT information to the Integrated Avionics System, and communicate with the primary PFD, Integrated Avionics Unit, and AHRS units. The Air Data Computer(s) is also connected directly to the Outside Air Temperature probe(s) and Pitot-Static System.

28 VDC for ADC 1 operation is supplied through the 5-amp ADC 1 circuit breaker on the ESS BUS 1. If option installed, 28VDC for ADC 2 operation is supplied through a 5-amp AHRS 2 / ADC 2 circuit breaker on the MAIN BUS 2.

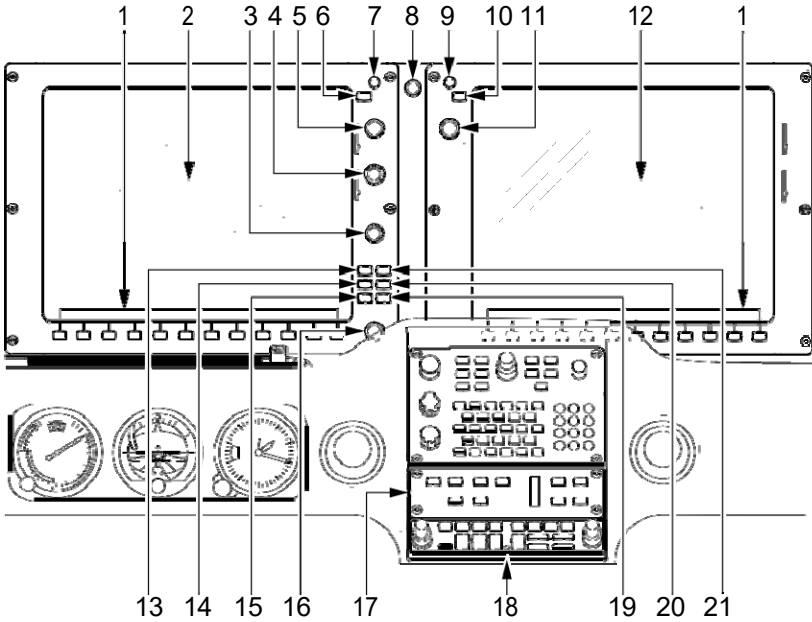

Legend

- | | |
|--|--------------------------------------|
| 1. Soft Keys | 11. NAV Transceiver Selection & Tune |
| 2. PFD | 12. MFD |
| 3. PFD Range/Pan Joystick | 13. PFD Direct-to-Course |
| 4. Barometric Pressure | 14. PFD Flight Plan Page |
| 5. COM Transceiver Selection & Tune | 15. PFD Clear/Cancel Information |
| 6. COM Frequency Transfer
(& 121.5 Emer Tune) | 16. PFD Flight Management System |
| 7. COM Volume and Squelch | 17. GFC 705 Mode Controller (opt) |
| 8. Display Backup Selection | 18. Audio Panel |
| 9. NAV and ID Audio Volume | 19. PFD Enter Key |
| 10. NAV Frequency Transfer | 20. PFD Procedures |
| | 21. PFD Menu Key |

T1_FM07_2808A

Figure 7-18
Integrated Integrated Avionics System (Sheet 1 of 2)

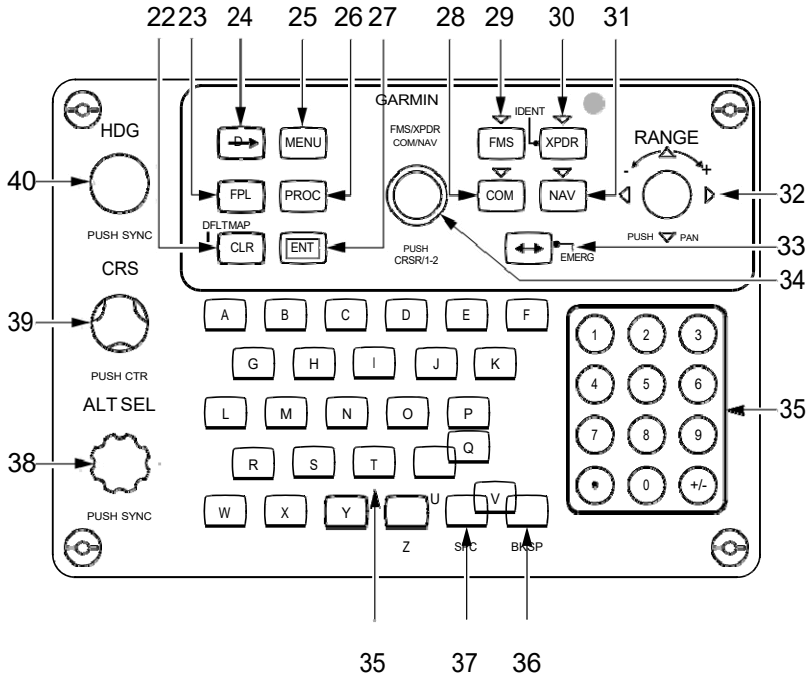

Flight Management System Keyboard

Legend

- | | |
|--|-------------------------------------|
| 22. MFD Clear/Cancel Information (Default Map) | 31. NAV Tuning Mode |
| 23. MFD Flight Plan Page | 32. MFD Range/Pan Joystick |
| 24. MFD Direct-to-Course | 33. Frequency Transfer (121.5 Tune) |
| 25. MFD Menu | 34. MFD FMS XPDR/NAV/COM Control |
| 26. MFD Procedures | 35. Alphanumeric Keys |
| 27. MFD Enter Key | 36. Backspace Key |
| 28. COM Tuning Mode | 37. Space Key |
| 29. FMS Mode | 38. Altitude Selection (PFD) |
| 30. Transponder Mode (Ident) | 39. Course Selection (HSI) |
| | 40. Heading Selection (PFD HSI) |

T1_FM07_2821

Figure 7-18

GIA 63W Integrated Avionics Units

The Integrated Avionics Units, located behind the MFD and instrument panel, function as the main communication hub, linking all Integrated Avionics System components with the PFD. Each Integrated Avionics Unit contains a GPS WAAS receiver, VHF COM/NAV/GS receivers, system integration microprocessors, and flight director if the optional AFCS is installed. The Integrated Avionics Units are not paired together and do not communicate with each other directly.

28 VDC for Integrated Avionics Unit 1 operation is supplied through the 7.5-amp COM 1 and 5-amp GPS NAV GIA 1 circuit breakers on the ESS BUS 1. 28 VDC for Integrated Avionics Unit 2 operation is supplied through the 7.5-amp COM 2 and 5-amp GPS NAV GIA 2 circuit breakers on the MAIN BUS 2.

GEA 71 Engine Airframe Unit

The Engine Airframe Unit, mounted behind the MFD, receives and processes analog signals from the fuel gaging system, CHT, EGT, MAP, RPM and other sensors and transmits this data to the Integrated Avionics Unit.

28 VDC for Engine Airframe Unit operation is supplied through the 3-amp ENGINE INSTR circuit breaker on the ESS BUS 2.

GTX 32 Transponder

The GTX 32 solid-state transponder communicates with the primary Integrated Avionics Unit and provides Modes A and C interrogation/reply capabilities. The transponder is controlled via the PFD or Flight Management System Keyboard and is located in the empennage avionics compartment.

28 VDC for Transponder operation is supplied through the 2-amp XPONDER circuit breaker on AVIONICS BUS. Refer to the Integrated Integrated Avionics System Pilot's Guide for a complete description of the system, its operating modes, and additional detailed operating procedures.

Airplane and Systems Description***GMA 347 Audio Panel with Integrated Marker Beacon Receiver***

The Audio Panel, installed on the center console below the Flight Management System Keyboard, integrates NAV/COM digital audio, intercom and marker beacon controls. The VHF communications portion of the unit interfaces with both Integrated Avionics Units to provide external radio communication, receive and demodulate VOR, Localizer, and Glide Slope signals.

28 VDC for Audio Panel operation is supplied through the 5-amp AUDIO PANEL circuit breaker on the AVIONICS bus.

• Note •

COM swap mode is not available in this installation.

For a detailed operating instructions, refer to the GMA 347 Audio Panel Pilot's Guide.

Annunciation and Alert System

Aircraft annunciations and alerts are displayed in the Crew Alerting System (CAS) window located to the right of the altimeter and VSI. Aircraft annunciations are grouped by criticality and sorted by order of appearance with the most recent message on top. The color of the message text is based on its urgency and required action:

- Warning (red) – Immediate crew awareness and action required.
- Caution (yellow) – Immediate crew awareness and future corrective action required.
- Advisory (white) – Crew awareness required and subsequent action may be required.

In combination with the CAS Window, the system issues an audio alert when specific system conditions are met and an expanded description of the condition is displayed in the Alerts Window located in the lower RH corner of the PFD.

• Note •

For specific pilot actions in response to System Annunciations, refer to Section 3 - Emergency Procedures and Section 3A - Abnormal Procedures.

For additional information on Engine Instrument Markings and Annunciations, refer to Section 2 - Limitations.

Optional Avionics

GFC 700 3-Axis Autopilot and GMC 705 Autopilot Controller

Refer to Section 9, Supplements for GFC 700 3-Axis Autopilot operating information.

GTX 33 Mode S Transponder

The GTX 33 Mode S solid-state transponder communicates with the primary Integrated Avionics Unit and provides Modes A, C, and S interrogation/reply capabilities. The transponder is controlled via the PFD or Flight Management System Keyboard and is located in the empennage avionics compartment.

28 VDC for Mode S Transponder operation is supplied through the 2-amp XPONDER circuit breaker on AVIONICS BUS. Refer to the Integrated Avionics System Pilot's Guide for a complete description of the system, its operating modes, and additional detailed operating procedures.

GDL 69/69A XM Satellite Weather and Radio

The Data Link Satellite Receiver, mounted in the empennage avionics compartment, receives and transmits real-time weather information to the MFD and PFD. If GDL 69A option is installed, this unit also provides digital XM audio entertainment to the cabin audio system via the GRT 10 XM Radio Remote Transceiver, mounted in the empennage avionics compartment and controlled by the GRC 10 Remote Control.

28 VDC for Satellite Data Link Receiver operation is supplied through the 3-amp WEATHER circuit breaker on AVIONICS BUS. Refer to the Integrated Avionics System Pilot's Guide for a complete description of the system, its operating modes, and additional detailed operating procedures.

S-Tec System 55X Autopilot with optional Flight Director System

Refer to Section 9, Supplements for S-Tec System 55X Autopilot operating information.

S-Tec System 55SR Autopilot

Refer to Section 9, Supplements for S-Tec System 55SR Autopilot operating information.

Airplane and Systems Description***Traffic Advisory System***

The Traffic Advisory System (TAS) advises the pilot of transponder-equipped airplane that may pose a collision threat. TAS information is displayed on the MFD and indicates the relative range, bearing, and altitude of intruder airplane. The Traffic Advisory System consists of a Transmitter Receiver Computer under the LH cockpit seat, and two directional antennas installed on the airplane exterior. The system utilizes inputs from the secondary Integrated Avionics Units via the primary Air Data Computer and is controlled via the MFD or Flight Management System Keyboard.

28 VDC for Traffic Advisory System operation is supplied through the 5-amp TRAFFIC circuit breaker on AVIONICS BUS. Refer to the Integrated Avionics System Pilot's Guide for a general description of the system and its operating modes. If applicable, refer to the L-3 Skywatch Pilot's Guide for a detailed discussion of the Traffic Advisory System.

Weather Information System

The Weather Information System detects electrical discharges associated with thunderstorms and displays the activity on the MFD. The system consists of an antenna located on top of the fuselage and a processor unit mounted under the aft baggage floor. The antenna detects the electrical and magnetic fields generated by intra-cloud, inter-cloud, or cloud to ground electrical discharges occurring within 200 nm of the airplane and sends the "discharge" data to the processor. The processor digitizes, analyzes, and converts the "discharge" signals into range and bearing data and communicates the data to the MFD every two seconds via the secondary Integrated Avionics Unit.

28 VDC for Weather System operation is supplied through the 3-amp WEATHER circuit breaker on AVIONICS BUS. Refer to the Integrated Avionics System Pilot's Guide for a general description of the system and its operating modes. If applicable, refer to the L-3 Stormscope WX-500 Weather Mapping Sensor Pilot's Guide for a detailed discussion of the system.

Bendix/King KR 87 Automatic Direction Finder (ADF)

The KR 87 ADF System is used as a means of identifying positions, receiving low and medium frequency voice communications, homing, tracking, and for navigation on instrument approach procedures. The system consists of an antenna installed on the airplane exterior and

the KR 87 receiver which communicates with the Integrated Avionics System via the secondary Integrated Avionics Unit. The HSI Bearing Needle may be configured to indicate ADF tracking and homing information. 28 VDC for ADF System operation is supplied through the 3-amp DME/ADF circuit breaker on AVIONICS BUS. Refer to the Integrated Avionics System Pilot's Guide for a general description of the system and its operating modes. Refer to the Bendix/King ADF System Pilot's Guide for a detailed discussion of the system.

Bendix/King KN 63 Distance Measuring Equipment (DME)

The KN 63 DME determines airplane distance to a land-based transponder by sending and receiving pulse pairs - two pulses of fixed duration and separation. The ground stations are typically collocated with VORs. The system consists of an antenna installed on the airplane exterior and the KN 63 receiver which communicates with the Integrated Avionics System via the secondary Integrated Avionics Unit. 28 VDC for ADF System operation is supplied through the 3-amp DME/ADF circuit breaker on AVIONICS BUS. Refer to the Integrated Avionics System Pilot's Guide for a general description of the system and its operating modes. Refer to the Bendix/King DME System Pilot's Guide for a detailed discussion of the system.

Synthetic Vision System

The Synthetic Vision System (SVS) is intended to provide the pilot with enhanced situational awareness by placing a three-dimensional depiction of terrain, obstacles, traffic and the desired flight path on the PFD so that proximity and location is more easily understood during instrument scanning. The SVS database is created from a digital elevation model with a 9 arc-sec (approx. 885 ft (270m)) horizontal resolution.

The synthetic vision system is not intended to be used independently of traditional attitude instrumentation. Consequently, SVS is disabled when traditional attitude instrumentation is not available. Otherwise, the traditional attitude instrumentation will always be visible in the foreground with SVS features in the background. The PFD with SVS installed includes:

- Integrated depiction of surrounding terrain,
- Zero pitch line,
- Integrated depiction of runways,
- Integrated depiction of large bodies of water,

Airplane and Systems Description

- Integrated depiction of obstacles,
- Flight path marker,
- Terrain warning system,
- Field of view depiction on the MFD Navigation Page.

Refer to the Integrated Avionics System Pilot's Guide for a complete description of the system, its operating modes, and additional detailed operating procedures.

Max Viz Enhanced Vision System

The Enhanced Vision System is an electro-optical system that uses a Long-Wave Infrared (IR) camera. Infrared is particularly effective at night, smoke, haze, and smog in addition to a broad spectrum of rain, snow, and radiation-type fog. However, penetration is limited during certain environmental conditions associated with heavy rain, heavy snow, coastal fog and most cloud formations. Therefore, the EVS is not intended for all atmospheric conditions and may only be used for acquisition of objects normally viewed through the cockpit windows. EVS is an aid to visual acquisitions of:

- Ground vehicles and other ground-based equipment/obstacles,
- Aircraft on taxi-ways and runways,
- Other traffic during takeoff, approach, and landing,
- Runway and taxi lights,
- Runway and terrain features during climb, descent, and low altitude maneuvering.

The EVS sensor, located on the underside of the LH wing, contains a long-wave infrared camera that produces a infrared image and a low-light CMOS camera that produces a visible image. The two images are then combined to produce a single fused image and transmitted directly to the MFD. Upon power-up the Sensor requires approximately 90 seconds to produce a usable image. The image generated is a monochrome image. The hotter an object is the whiter it appears on the display.

28 VDC Enhanced Vision System operation is supplied through the 5-amp EVS CAMERA circuit breaker on MAIN BUS 3. Refer to the Max Viz Enhanced Vision System Pilot's Guide for a detailed discussion of the system. For maintenance information and special precautions to be followed, refer to Section 8, Ground Handling, Servicing, and Maintenance.

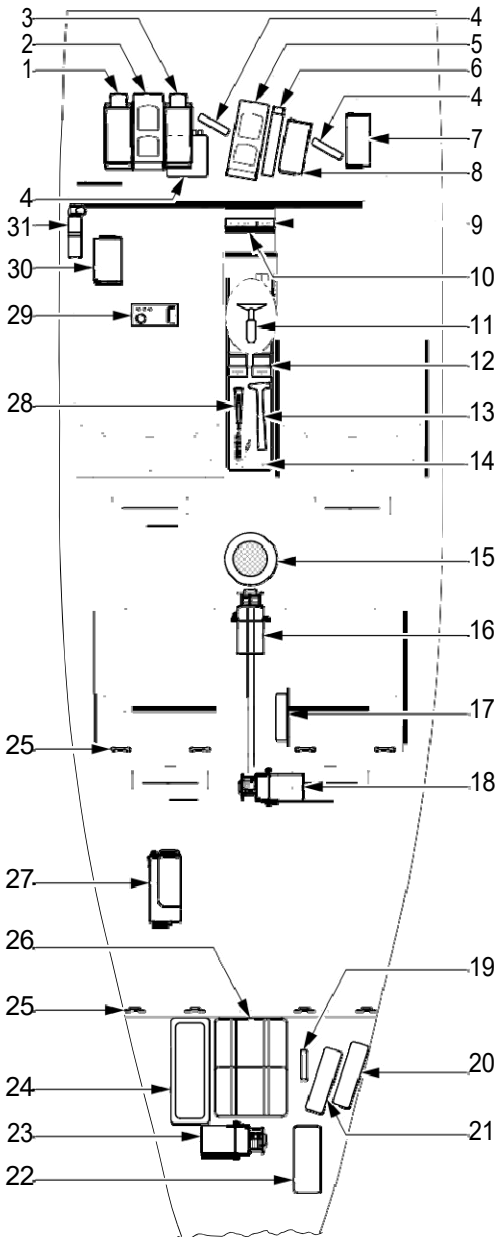

LEGEND

1. AHRS 1
2. Integrated Avionics Unit 1
3. AHRS 2
4. Avionics Cooling Fan
5. Integrated Avionics Unit 2
6. Engine Airframe Unit
7. Air Data Computer 2 (opt)
8. Air Data Computer 1
9. GFC 705 Mode Controller (opt)
10. ADF (Opt)
11. APS Activation Handle (Cabin Ceiling)
12. Hour Meters
13. Egress Hammer
14. Telephone and Audio Jacks
15. Cabin Speaker
16. Roll Servo (opt)
17. Pitch Trim Adapter (opt)
18. Pitch Servo (opt)
19. XM Radio Transceiver (Opt)
20. Transponder
21. Satellite Data Link Receiver (Opt)
22. ELT
23. Yaw Servo (opt)
24. Battery 2
25. Tiedown Loops
26. APS Parachute
27. WX Information Receiver (Opt)
28. Microphone
29. TAS Receiver (Opt)
30. DME (Opt)
31. Fire Extinguisher

T1_FM07_2786C

**Figure 7-19
Equipment Locations**

Avionics Support Equipment

Antennas

Two rod-type COM antennas are mounted to the airplane's exterior; COM 1 is mounted directly above the passenger compartment, COM 2 is mounted directly below the baggage compartment. These antennas are connected to the two VHF communication transceivers contained in the Integrated Avionics Units.

The optional blade-type DME antenna is mounted on the airplane underside just aft, right of the firewall.

The optional combined loop/sense ADF antenna is mounted to the underside of the airplane just aft of the main wing spar. The antenna combines antenna signals into a single signal input to the ADF receiver.

A sled-type marker beacon antenna is mounted to the underside of the airplane below the baggage compartment and provides a signal to the marker beacon receiver located in the GMA 347 audio panel. If the optional air conditioning system is installed this antenna is located below the baggage floor inside of the airplane.

The transponder antenna is located on the bottom side of the airplane, just aft of the baggage compartment bulkhead on the RH side of the airplane.

GPS 1 antenna is mounted directly above the passenger compartment. If the optional XM system is installed, a combination GPS1/XM antenna is installed in this location. GPS 2 antenna is mounted just forward of the baggage compartment window. These antennas are connected to the two GPS receivers contained in the Integrated Avionics Units.

The optional Traffic System antenna is mounted just above the pilot/copilot compartment.

If the Garmin GTS 800 Series Traffic Advisory System is installed, a second blade-type antenna is located on the bottom RH side of the airplane just forward of the baggage compartment.

The optional The Weather System antenna is mounted directly above the passenger compartment.

The Navigation antenna is mounted to the top of the vertical fin. This antenna provides VOR and glide-scope signals to the VHF navigation receivers contained in the Integrated Avionics Units.

Headset and Microphone Installation

The airplane is equipped with provisions for four noise-canceling headsets with integrated microphones. The forward microphone-headsets use remote Push-To-Talk (PTT) switches located on the top of the associated control yoke grip. The rear headsets do not have COM transmit capabilities and do not require PTT switches. The microphone (MIC), headset, and automatic noise reduction (ANR) power jacks for the pilot and front seat passenger are located in the map case and similar jacks for the aft passengers are located on the aft portion of the center console. Audio to all four headsets is controlled by the individual audio and volume selectors on the audio control panel.

Audio Input Jack

Two 3.5 mm audio input jacks (AUDIO INPUT) are provided on the aft portion of the center console. One jack is located near the convenience outlet for use by the pilot and forward passenger, and another is located further aft by the rear passenger ANR power jacks. These jacks can be used to plug in personal entertainment devices such as portable radios, cassette players, or CD players. Audio volume through these jacks is controlled by connected individual entertainment device.

Cell Phone Input Jack

One 2.5 mm cell phone jack (CELL PHONE INPUT) is provided on the aft portion of the center console near the convenience outlet. This jack provides full-duplex telephone interface with intercom isolation and disable capability. Cabin audio volume through this jack is controlled by the volume selector on the audio control panel.

Avionics Cooling Fans

Electric fans provide forced ambient-air cooling for the Integrated Avionics System. A fan located forward of the instrument panel provides ambient air cooling directly to the Integrated Avionics Units. Two additional fans blow air directly onto the heat sinks located on the forward sides of the PFD and MFD. *Serials 3026 thru 3369*; Air is ported directly into the transponder by a single fan in the empennage avionics bay. 28 VDC for MFD and Transponder Fan operation is supplied through the 5-amp AVIONICS FAN 1 circuit breaker on NON-ESSENTIAL BUS. 28 VDC for PFD and Integrated Avionics Unit Fan operation is supplied through the 5-amp AVIONICS FAN 2 circuit breaker on MAIN BUS 2.

Cabin Features

Emergency Locator Transmitter

The airplane is equipped with a self-contained emergency locator transmitter (ELT). The transmitter and antenna are installed immediately behind the aft cabin bulkhead, slightly to the right of the airplane centerline. The main transmitter control switch, labeled ON-OFF-ARMED, on the transmitter is in the armed position for normal operations. A remote switch and indicator panel is installed on the left console near the pilot's right knee. If rapid deceleration is detected, the transmitter will repeatedly transmit VHF band audio sweeps at 121.5 MHz and 243.0 MHz approximately 0.5 seconds apart.

The transmitter and antenna are accessible through the avionics bay access panel along the aft portion of the RH fuselage or the lower aft center access panel of baggage compartment. The ELT can be removed from the airplane and used as a personal locating device if it is necessary to leave the airplane after an accident. Eight dated "D" cell alkaline batteries contained within the transmitter unit power the ELT transmitter. The batteries must be replaced at specified intervals based upon the date appearing on the battery (Refer to Airplane Maintenance Manual).

ELT Remote Switch and Indicator Panel

The ELT remote switch and indicator panel, located on the left console near the pilot's right knee, provides test and monitoring functions for the ELT. The panel contains a button labeled ON, a button labeled RESET, and a red LED (light). The red-light flashes when the ELT is transmitting. The ON button is used to test the unit in accordance with the maintenance manual procedures. The RESET button can be used to cancel an inadvertent transmission. A 6-volt Lithium battery mounted in the panel powers the LED. The battery must be replaced at regular intervals (Refer to Airplane Maintenance Manual).

In the event of an accident:

1. Verify ELT operation by noting that the ELT indicator light on the remote panel is flashing.
2. If possible, access the unit as described below and set the ELT main transmitter control switch ON.

Portable use of ELT:

- a. Remove access at lower aft center of baggage compartment.

- b. Disconnect fixed antenna lead from front of unit.
- c. Disconnect lead from remote switch and indicator unit.
- d. Loosen attach straps and remove transmitter unit and portable antenna.
- e. Attach portable antenna to antenna jack on front of unit.
- f. Set main control switch to ON.
- g. Hold antenna upright as much as possible.

Fire Extinguisher

A liquefied-gas-type fire extinguisher, containing Halon 1211/1301 extinguishing agent, is mounted on the forward outboard side of the pilot-side footwell. The extinguisher is approved for use on class B (liquid, grease) and class C (electrical equipment) fires. The Halon 1211/1301 blend provides the best fire extinguishing capability with low toxicity. A pin is installed through the discharge mechanism to prevent inadvertent discharge of extinguishing agent. The fire extinguisher must be replaced after each use.

To operate the extinguisher:

1. Loosen retaining clamp and remove the extinguisher from its mounting bracket.
2. Hold the extinguisher upright and pull the pin.
3. Get back from the fire and aim nozzle at base of fire at the nearest edge.
4. Press red lever and sweep side to side.

The extinguisher must be visually inspected before each flight to assure that it is available, charged, and operable. The preflight inspection consists of ensuring that the nozzle is unobstructed, the pin has not been pulled, and the canister has not been damaged. Additionally, the unit should weigh approximately 1.5 lb. (0.7 kg). For preflight, charge can be determined by 'hefting' the unit.

Airplane and Systems Description**Hour Meters**

The airplane is equipped with two-hour meters located inside the armrest storage compartment between the pilot and copilot seats. The #1hour meter, labeled HOBBS begins recording when the BAT 1 switch is ON and either the ALT 1 or ALT 2 switch is ON. The #2hour meter records flight time and is labeled FLIGHT. Recording begins when the airplane reaches a speed of approximately 35 KIAS and is controlled by the Engine Airframe Unit.

28 VDC for hour meter operation is supplied through the 5-amp FUEL QTY circuit breaker on MAIN BUS 1.

Emergency Egress Hammer

An eight-ounce ball-peen type hammer is located in the center armrest accessible to either front seat occupant. In the event of a mishap where the cabin doors are jammed or inoperable, the hammer may be used to break through the acrylic windows to provide an escape path for the cabin occupants.

Convenience Outlet

A 12-volt convenience outlet is installed in the center console. The receptacle accepts a standard cigarette-lighter plug. The outlet may be used to power portable entertainment equipment such as CD players, cassette players, and portable radios. Amperage draw through the outlet must not exceed 3.5 amps. Power for the convenience outlet is supplied through the 5-amp 12V DC OUTLET circuit breaker on the MAIN BUS 3.

ATPI Airplane Parachute System

The airplane is equipped with a ATPI Airplane Parachute System (APS) designed to bring the airplane and its occupants to the ground in the event of a life-threatening emergency. The system is intended to save the lives of the occupants but will most likely destroy the airplane and may, in adverse circumstances, cause serious injury or death to the occupants. Because of this it is important to carefully read the APS descriptions in this section, section 3 Emergency Procedures and Section 10, Safety and consider when and how you would use the system.

• WARNING •

The parachute system does not require electrical power for activation and can be activated at any time. The solid-propellant rocket flight path is upward from the parachute cover. Stay clear of parachute canister area when airplane is occupied. Do not allow children in the airplane unattended.

System Description

The APS consists of a parachute, a solid-propellant rocket to deploy the parachute, a rocket activation handle, and a harness imbedded within the fuselage structure.

A composite box containing the parachute and solid-propellant rocket is mounted to the airplane structure immediately aft of the baggage compartment bulkhead. The box is covered and protected from the elements by a thin composite cover.

The parachute is enclosed within a deployment bag that stages the deployment and inflation sequence. The deployment bag creates an orderly deployment process by allowing the canopy to inflate only after the rocket motor has pulled the parachute lines taut.

The parachute itself is a 2400-square-foot round canopy equipped with a slider, an annular-shaped fabric panel with a diameter significantly less than the open diameter of the canopy. The slider has grommets spaced around its perimeter. The canopy suspension lines are routed through these grommets so that the slider is free to move along the suspension lines. Since the slider is positioned at the top of the suspension lines near the canopy, at the beginning of the deployment sequence the slider limits the initial diameter of the parachute and the

Airplane and Systems Description

rate at which the parachute inflates. As the slider moves down the suspension lines the canopy inflates.

A three-point harness connects the airplane fuselage structure to the parachute. The aft harness strap is stowed in the parachute canister and attached to the structure at the aft baggage compartment bulkhead. The forward harness straps are routed from the canister to firewall attach points just under the surface of the fuselage skin. When the parachute deploys, the forward harness straps pull through the fuselage skin covering from the canister to the forward attach points.

Activation Handle

APS is initiated by pulling the APS Activation T-handle installed in the cabin ceiling on the airplane centerline just above the pilot's right shoulder. A placarded cover, held in place with hook and loop fasteners, covers the T-handle and prevents tampering with the control. The cover is removed by pulling the black tab at the forward edge of the cover.

Pulling the activation T-handle will activate the rocket and initiate the APS deployment sequence. To activate the rocket, two separate events must occur:

1. Pull the activation T-handle from its receptacle. Pulling the T-handle removes it from the O-ring seal that holds it in place and takes out the slack in the cable (approximately two inches (5 cm) of cable will be exposed). Once the slack is removed, the T-handle motion will stop and greater force will be required to activate the rocket.
2. Clasp both hands around activation T-handle and pull straight downward with a strong, steady, and continuous force until the rocket activates. A chin-up type pull works best. Up to 45.0 pounds (20.4 Kg) force, or greater, may be required to activate the rocket. The greater force required occurs as the cable arms and then releases the rocket igniter firing pin. When the firing pin releases, two primers discharge and ignite the rocket fuel.

• Note •

Jerking or rapidly pulling on the activation T-handle greatly increases the pull forces required to activate the rocket.

Attempting to activate the rocket by pushing the activation T-handle forward and down limits the force that can be applied.

Pulling the activation T-handle straight down generates the greatest force.

A maintenance safety pin is provided to ensure that the activation handle is not pulled during maintenance. However, there may be some circumstances where an operator may wish to safety the APS system; for example, the presence of unattended children in the airplane, the presence of people who are not familiar with the APS activation system in the airplane, or during display of the airplane.

The pin is inserted through the handle retainer and barrel locking the handle in the “safe” position. A “Remove Before Flight” streamer is attached to the pin.

• WARNING •

After maintenance has been performed or any other time the system has been safety tied, operators must verify that the pin has been removed before further flight.

Deployment Characteristics

When the rocket launches, the parachute assembly is extracted outward due to rocket thrust and rearward due to relative wind. In approximately two seconds the parachute will begin to inflate.

When air begins to fill the canopy, forward motion of the airplane will dramatically be slowed. This deceleration increases with airspeed but in all cases within the parachute envelope should be less than 3 g's. During this deceleration a slight nose-up may be experienced, particularly at high speed; however, the rear riser is intentionally snubbed short to preclude excessive nose-up pitch. Following any nose-up pitching, the nose will gradually drop until the airplane is hanging nose-low beneath the canopy.

Eight seconds after deployment, the rear riser snub line will be cut and the airplane tail will drop down into its final approximately level attitude. Once stabilized in this attitude, the airplane may yaw slowly back and forth or oscillate slightly as it hangs from the parachute. Descent rate is expected to be less than 1700 feet per minute with a lateral speed equal to the velocity of the surface wind. In addition, surface winds may continue to drag the airplane after ground impact.

• Caution •

Ground impact is expected to be equivalent to touchdown from a height of approximately 13 feet. While the airframe, seats and landing gear are designed to accommodate this stress, occupants must prepare for it in accordance with the APS Deployment procedure in Section 3 - Emergency Procedures.

• Note •

The APS is designed to work in a variety of airplane attitudes, including spins. However, deployment in an attitude other than level flight may yield deployment characteristics other than those described above.

Intentionally Left Blank

Section 8

Handling, Servicing, & Maintenance

Table of Contents

Introduction	3
Operator's Publications.....	3
Service Publications	3
Ordering Publications	4
Airplane Records and Certificates.....	5
Airworthiness Directives	6
Airplane Inspection Periods	6
Annual Inspection	6
100--Hour Inspection.....	7
ATPI Design Progressive Inspection Program.....	7
Pilot Performed Preventative Maintenance.....	8
Ground Handling.....	10
Application of External Power	10
Towing	11
Taxiing	12
Parking.....	13
Tiedown	14
Leveling.....	14
Jacking.....	14
Servicing	16
Landing Gear Servicing	16
Brake Servicing.....	16
Tire Inflation	18
Propeller Servicing	18
Oil Servicing.....	18
Fuel System Servicing.....	21
Fuel Contamination and Sampling	22
Draining Fuel System	23
Battery Service.....	24
Cleaning and Care	25
Cleaning Exterior Surfaces.....	25
Cleaning Interior Surfaces.....	29

Intentionally Left Blank

Introduction

This section provides general guidelines for handling, servicing and maintaining your aircraft. In order to ensure continued safe and efficient operation of your airplane, keep in contact with your Authorized ATPI Service Center to obtain the latest information pertaining to your aircraft.

Operator's Publications

The FAA Approved Airplane Flight Manual and Pilot's Operating Handbook (POH) is provided at delivery. Additional or replacement copies may be obtained from ATPI Design by contacting the Customer Service Department.

Service Publications

The following service publications are available for purchase from ATPI Design:

- Airplane Maintenance Manual (AMM) – Maintenance Manual divided into chapters as specified by GAMA and ATA covering inspection, servicing, maintenance, troubleshooting, and repair of the airplane structure, systems, and wiring. Revision Service for this manual is also available. A current copy of the AMM is provided at delivery.
- Engine Operators and Maintenance Manual – ATPI Design provides a Teledyne Continental Engine Operator's and Maintenance Manual at the time of delivery. Engine and engine accessory overhaul manuals can be obtained from the original equipment manufacturer.
- Avionics Component Operator and Maintenance Manuals — ATPI Design provides all available operator's manuals at the time of delivery. Maintenance manuals, if available, may be obtained from the original equipment manufacturer.

ATPI Design offers a Subscription Service for the Service Bulletins, Service Letters and Options Letters issued from the factory. This service is offered to interested persons such as owners, pilots and mechanics at a nominal fee. Interested parties may obtain copies and subscription service for these documents by contacting Customer Service at ATPI Design.

- Service Bulletins – are of special importance. When you receive a Service Bulletin, comply with it promptly.

Handling, Servicing, and Maintenance

- Service Advisory Notices – are used to notify you of optional Service Bulletins, supplier Service Bulletins or Service Letters affecting your airplane, and maintenance data or corrections not requiring a Service Bulletin. Give careful attention to the Service Advisory Notice information.

Ordering Publications

Aircraft publications subscription service may be obtained by contacting Customer Service online as follows:
<http://www.aviationtpi.com>

Make sure to include airplane serial number and owner's name in all correspondence for accurate processing of your documentation needs.

Airplane Records and Certificates

The Federal Aviation Administration (FAA) requires that certain data, certificates, and licenses be displayed or carried aboard the airplane at all times. Additionally, other documents must be made available upon request. The mnemonic acronym “ARROW” is often used to help remember the required documents.

• Note •

Owners of aircraft not registered in the United States should check with the registering authority for additional requirements.

Required Documents		Note
A	Airworthiness Certificate FAA Form 8100-2	Must be displayed at all times.
R	Registration Certificate FAA Form 8050-3	Must be in the aircraft for all operations.
R	Radio Station License FCC Form 556	Required only for flight operations outside the United States.
O	Operating Instructions	FAA Approved Flight Manual and Pilot's Operating Handbook fulfills this requirement.
W	Weight & Balance Data	Included in FAA Approved Airplane Flight Manual and Pilot's Operating Handbook. Data must include current empty weight, CG, and equipment list.

Other Documents	Note
Airplane Logbook	Must be made available upon request.
Engine Logbook	Must be made available upon request.
Pilot's Checklist	Available in cockpit at all times.

Airworthiness Directives

The Federal Aviation Administration (FAA) publishes Airworthiness Directives (AD's) that apply to specific aircraft and aircraft appliances or accessories. AD's are mandatory changes and must be complied with within a time limit set forth in the AD. Operators should periodically check with ATPI Service Centers or A&P mechanic to verify receipt of the latest issued AD for their airplane.

Airplane Inspection Periods

• Note •

FAR 1.1 defines time in service, with respect to maintenance time records, as “the time from the moment an aircraft leaves the surface of the earth until it touches it at the next point of landing.”

The #2 Hour Meter, located in the center console and labeled FLIGHT, begins recording when the airplane reaches approximately 35 KIAS and should be used to track maintenance time intervals as it more accurately records time in service than the #1 Hour Meter.

The inspection items specified in the Annual/100 Inspection have been determined by the average aircraft use rate of the typical owner. Non-commercially operated aircraft that are flown significantly more than 100 hours per year should consider additional inspections commensurate with the hours flown. 100-Hour Inspection or enrollment in a Progressive Inspection Program should be considered in addition to the normally required Annual Inspection. The Annual Inspection interval may also be shortened to accommodate high utilization rate.

Annual Inspection

Unless enrolled in a Progressive Inspection Program, The U.S. Federal Aviation Regulations require all civil aircraft must undergo a thorough Annual Inspection each twelve calendar months. Annual Inspections are due on the last day of the twelfth month following the last Annual Inspection. For example: If an Annual Inspection were performed on 19 November 2010, the next Annual Inspection will be due 30 November 2018. Annual Inspections must be accomplished regardless of the number of hours flown the previous year and can

only be performed by a licensed Airframe and Powerplant (A&P) mechanic holding an Inspection Authorization (IA). All ATPI Authorized Service Centers can perform Annual Inspections. The inspection is listed, in detail, in Chapter 5 of the Aircraft Maintenance Manual.

100-Hour Inspection

If the airplane is used commercially, in addition to the Annual Inspection requirement, the Federal Aviation Regulations requires that the airplane undergo a 100-Hour Inspection each 100 hours of flight operation. The scope of the 100-Hour Inspection is identical to the Annual Inspection except that it can be accomplished by a licensed A&P mechanic. The 100-hour interval may be exceeded by not more than 10 flight hours in order to reach a place where the inspection can be accomplished. Any flight hours used to reach an inspection station must be deducted from the next 100-Hour Inspection interval. The inspection is listed, in detail, in Chapter 5 of the Aircraft Maintenance Manual.

ATPI Design Progressive Inspection Program

In lieu of the above requirements, an airplane may be inspected using a Progressive Inspection Program in accordance with the Federal Aviation Regulation Part 91.409.

The ATPI Design Progressive Inspection Program provides for the complete inspection of the airplane utilizing a five-phase cyclic inspection program. A total of eight inspections are accomplished over the course of 400 flight hours, with an inspection occurring every 50 flight hours. The inspection items to be covered in the Progressive Inspection are very similar to the Annual Inspection items. The Progressive Inspection will accomplish a full Inspection of the airplane at 400 flight hours or at 12 calendar months. The inspection is listed, in detail, in Chapter 5 of the Aircraft Maintenance Manual.

Pilot Performed Preventative Maintenance

The holder of a Pilot Certificate issued under FAR Part 61 may perform certain preventive maintenance described in FAR Part 43, Appendix A. This maintenance may be performed only on an aircraft that the pilot owns or operates and which is not used in air carrier service. The regulation also stipulates that the pilot must also complete the appropriate logbook entries. The following is a list of the maintenance that the pilot may perform:

• Note •

The pilot should have the ability and manual procedures for the work to be accomplished.

The pilot may not accomplish any work involving the removal or disassembly of primary structure or operating system, or interfere with an operating system, or affect the primary structure.

- Remove, install, and repair tires.
- Clean, grease, or replace wheel bearings.
- Replace defective safety wire or cotter pins.
- Lubrication not requiring disassembly other than removal of non-structural items such as access covers, cowlings, or fairings.

• Caution •

Do not use unapproved lubricants. Unapproved lubricants may damage control system components, including but not limited to engine and flight controls. Refer to the AMM for approved lubricants.

- Replenish hydraulic fluid in the hydraulic and brake reservoirs.
- Refinish the airplane interior or exterior (excluding balanced control surfaces) with protective coatings.
- Repair interior upholstery and furnishings.
- Replace side windows.
- Replace bulbs, reflectors and lenses of position and landing lights.
- Replace cowling not requiring removal of the propeller.
- Replace, clean or set spark plug gap clearance.

- Replace any hose connection, except hydraulic connections, with replacement hoses.
- Clean or replace fuel and oil strainers, as well as replace or clean filter elements.
- Replace prefabricated fuel lines.
- Replace the battery and check fluid level and specific gravity.

Logbook Entry

After any of the above work is accomplished, appropriate logbook entries must be made. Logbook entries should contain:

- The date the work was accomplished.
- Description of the work.
- Number of hours on the aircraft.
- The certificate number of pilot performing the work.
- Signature of the individual doing the work.

Logbooks should be complete and up to date. Good records reduce maintenance cost by giving the mechanic information about what has or has not been accomplished.

Ground Handling

Application of External Power

A ground service receptacle, located just aft of the cowl on the left side of the airplane, permits the use of an external power source for cold weather starting and maintenance procedures.

• WARNING •

If external power will be used to start engine, keep yourself, others, and power unit cables well clear of the propeller rotation plane.

To apply external power to the airplane:

• Caution •

Do not use external power to start the airplane with a 'dead' battery or to charge a dead or weak battery in the airplane. The battery must be removed from the airplane and battery maintenance performed in accordance with the appropriate AMM procedures.

1. Ensure that external power source is regulated to 28 VDC.
2. Check BAT and AVIONICS power switches are 'off.'
3. Plug external power source into the receptacle.
4. Set BAT 1 switch to ON. 28 VDC from the external power unit will energize the main distribution and essential distribution buses. The airplane may now be started or electrical equipment operated.
5. If avionics are required, set AVIONICS power switch ON.

• Caution •

If maintenance on avionics systems is to be performed, it is recommended that external power be used. Do not start or crank the engine with the AVIONICS power switch 'on.'

To remove external power from airplane:

1. If battery power is no longer required, set BAT 1 switch 'off.'
2. Pull external power source plug.

Towing

The airplane may be moved on the ground by the use of the nose wheel steering bar that is stowed in the rear baggage compartment or by power equipment that will not damage or excessively strain the nose gear assembly. The steering bar is engaged by inserting it into lugs just forward of the nose wheel axle.

• Caution •

While pushing the aircraft backward, the tow bar must be installed to keep the nose wheel from turning abruptly.

Do not use the vertical or horizontal control surfaces or stabilizers to move the airplane. If a tow bar is not available, use the wing roots as push points.

Do not push or pull on control surfaces or propeller to maneuver the airplane.

Do not tow the airplane when the main gear is obstructed with mud or snow.

If the airplane is to be towed by vehicle, do not turn the nose wheel more than 90 degrees either side of center or structural damage to the nose gear could result.

1. Refer to Section 1, General, Airplane Three View and Turning Radius figures for clearances. Be especially cognizant of hangar door clearances.
2. Insert tow bar into the lugs just forward of the nose wheel axle.
3. Release parking brake and remove chocks
4. Move airplane to desired location.
5. Install chocks
6. Remove tow bar.

To obtain a minimum radius turn during ground handling, the airplane may be rotated around either main landing gear by pressing down on a fuselage just forward of the horizontal stabilizer to raise the nosewheel off the ground.

Taxiing

Before attempting to taxi the airplane, ground personnel should be instructed and authorized by the owner to taxi the airplane. Instruction should include engine starting and shutdown procedures in addition to taxi and steering techniques.

• **Caution** •

Verify that taxi and propeller wash areas are clear before beginning taxi.

Do not operate the engine at high RPM when running up or taxiing over ground containing loose stones, gravel, or any loose material that may cause damage to the propeller blades.

Taxi with minimum power needed for forward movement. Excessive braking may result in overheated or damaged brakes.

1. Remove chocks.
2. Start engine in accordance with Starting Engine procedure.
3. Release parking brake.
4. Advance throttle to initiate taxi. Immediately after initiating taxi, apply the brakes to determine their effectiveness. During taxiing, use differential braking to make slight turns to ascertain steering effectiveness.

• **Caution** •

Observe wing clearance when taxiing near buildings or other stationary objects. If possible, station an observer outside the airplane.

Avoid holes and ruts when taxiing over uneven ground.

5. Taxi airplane to desired location.
6. Shut down airplane and install chocks and tie-downs in accordance with Shutdown procedure.

Parking

The airplane should be parked to protect the airplane from weather and to prevent it from becoming a hazard to other aircraft. The parking brake may release or exert excessive pressure because of heat buildup after heavy braking or during wide temperature swings. Therefore, if the airplane is to be left unattended or is to be left overnight, chock and tie down the airplane.

1. For parking, head airplane into the wind if possible.
2. Retract flaps.
3. Set parking brake by first applying brake pressure using the toe brakes and then pulling the PARK BRAKE knob aft.

• Caution •

Care should be taken when setting overheated brakes or during cold weather when accumulated moisture may freeze a brake.

4. Chock both main gear wheels.
5. Tie down airplane in accordance with tiedown procedure in this section.
6. Install a Pitot head cover. Be sure to remove the Pitot head cover before flight.
7. Cabin and baggage doors should be locked when the airplane is unattended.

Tiedown

The airplane should be moored for immovability, security and protection. FAA Advisory Circular AC 20-35C, Tiedown Sense, contains additional information regarding preparation for severe weather, tiedown, and related information. The following procedures should be used for the proper mooring of the airplane:

1. Head the airplane into the wind if possible.
2. Retract the flaps.
3. Chock the wheels.
4. Secure tie-down ropes to the wing tie-down rings and to the tail ring at approximately 45-degree angles to the ground. When using rope or non-synthetic material, leave sufficient slack to avoid damage to the airplane should the ropes contract.

• Caution •

Anchor points for wing tiedowns should not be more than 18 feet apart to prevent eyebolt damage in heavy winds.

Use bowline knots, square knots, or locked slipknots. Do not use plain slipknots.

Leveling

The airplane is leveled longitudinally by means of a spirit level placed on the pilot door sill and laterally by means of a spirit level placed across the door sills. Alternately, sight the forward and aft tool holes along waterline 95.9 to level airplane. Refer to AMM Section 6, Airplane Weighing Procedures for illustration.

Jacking

Three jacking points, located at each wing tiedown and tail tiedown, are provided to perform maintenance operations. Tie-down rings must be removed and replaced with jack points prior to lifting. Jack points are stowed in the baggage compartment. The airplane may be jacked using two standard aircraft hydraulic jacks at the wing jacking points and a weighted tail-stand attached to the aft tail tiedown. Refer to AMM Section 7, Airplane Lifting Procedures for list of required tools and for illustration.

Raise Airplane**• Caution •**

Do not jack the aircraft outside or in open hangar with winds in excess of 10 mph.

The empty CG is forward of the wing jacking points. To prevent airplane from tipping forward during maintenance or jacking, use a weighted tail-stand (300-lb minimum) attached to the tail tiedown.

Jacks must be used in pairs. Do not attempt to jack only one side of aircraft. Keep the airplane as level as possible when jacking.

1. Position airplane on a hard, flat, level surface.
2. Remove main gear fairings. (Refer to AMM 32-10)
3. Remove and stow tie-down rings from wings.
4. Attach a weighted tail-stand to tail tiedown ring.
5. Position jacks and jack points for jacking. Insert jack point into wing tiedown receptacle. Holding the jack point in place, position the jack under the point and raise the jack to firmly contact the jack point. Repeat for opposite jacking point.
6. Raise airplane no more than required for maintenance being performed.
7. Raise the airplane keeping the airplane as level as possible.
8. Secure jack locks.

Lower Airplane

1. Release pressure on all jacks simultaneously to keep airplane as level as possible.
2. Remove jacks, jack points, and tail-stand. Stow points in baggage compartment.
3. Install tiedown rings.
4. Install main gear fairings. (Refer to AMM 32-10)

Servicing

Landing Gear Servicing

The main landing gear wheel assemblies use 15 x 6.00 x 6, six-ply rating tires and tubes. The nose wheel assembly uses a 5.00 x 5 four-ply rating, type III tire and tube. Always keep tires inflated to the rated pressure to obtain optimum performance and maximum service. The landing gear struts do not require servicing. With the exception of replenishing brake fluid, wheel and brake servicing must be accomplished in accordance with AMM procedures.

Brake Servicing

Brake Replenishing

The brake system is filled with MIL-H-5606 hydraulic brake fluid. The fluid level should be checked at every oil change and at the annual/100-hour inspection, replenishing the system when necessary. The brake reservoir is located on the right side of the battery support frame. If the entire system must be refilled, refer to the AMM.

To replenish brake fluid:

1. Chock tires and release parking brake.
2. Remove top engine cowling to gain access to hydraulic fluid reservoir.
3. Clean reservoir cap and area around cap before opening reservoir cap.
4. Remove cap and add MIL-H-5606 hydraulic fluid as necessary to fill reservoir.
5. Install cap, inspect area for leaks, and then install and secure engine cowling.

Brake Inspection

The brake assemblies and linings should be checked at every oil change (50 hours) for general condition, evidence of overheating, and deterioration. At every annual/100-hour inspection the brakes should be disassembled, the brake linings should be checked and the O-rings replaced.

The aircraft should not be operated with overheated, damaged, or leaking brakes. Conditions include, but are not limited to:

- Leaking brake fluid at the caliper. This can be observed by checking for evidence of fluid on the ground or deposited on the underside of the wheel fairing. Wipe the underside of the fairing with a clean, white cloth and inspect for red colored fluid residue.
- Overheated components, indicated by discoloration or warping of the disk rotor. Excessive heat can cause the caliper components to discolor or cause yellowing of the part identification label.

To inspect the brake assemblies:

1. Remove main gear fairing. (Refer to AMM 32-10)
2. Wipe off any debris from brake caliper assembly that may obstruct inspection.
3. Check brake linings for deterioration and maximum permissible wear. Replace lining when worn to 0.100 inch (2.54 mm).
4. Inspect temperature indicator(s):
 - a. Clean and inspect temperature indicators installed to brake caliper assembly.
 - b. Verify temperature indicators are firmly adhered to piston housing.
 - c. If either temperature indicator is black, the brake assembly has overheated. The brake linings must be inspected and the O-rings replaced.
5. Check brake assemblies for evidence of overheating and/or deterioration.
6. Install main gear fairing. (Refer to AMM 32-10)

Tire Inflation

For maximum service from the tires, keep them inflated to the proper pressure. When checking tire pressure, examine the tires for wear, cuts, nicks, bruises and excessive wear.

To inflate tires:

1. Remove inspection buttons on wheel pants to gain access to valve stems. It may be necessary to move airplane to get valve stem aligned with the access hole.
2. Remove valve stem cap and verify tire pressure with a dial-type tire pressure gage.
3. Inflate nose tire to 30 psi (207 kPa) and main wheel tires to 62 psi (427kPa).
4. Replace valve stem cap and inspection buttons.

All wheels and tires are balanced before original installation and the relationship of tire, tube, and wheel should be maintained upon reinstallation. In the installation of new components, it may be necessary to rebalance the wheels with the tires mounted. Unbalanced wheels can cause extreme vibration in the landing gear.

Propeller Servicing

The spinner and backing plate should be cleaned and inspected for cracks frequently. Before each flight the propeller should be inspected for nicks, scratches, and corrosion. If found, they should be repaired as soon as possible by a rated mechanic, since a nick or scratch causes an area of increased stress which can lead to serious cracks or the loss of a propeller tip. The back face of the blades should be painted when necessary with flat black paint to retard glare. To prevent corrosion, the surface should be cleaned and waxed periodically.

Oil Servicing

• Caution •

The engine should not be operated with less than six quarts of oil. Seven quarts (dipstick indication) is recommended for extended flights.

The oil capacity of the Teledyne Continental IO-550-N engine is 8 quarts. It is recommended that the oil be changed every 50 hours and

sooner under unfavorable operating conditions. The following grades are recommended for the specified temperatures at sea level (SL):

Ambient Air Temperature (SL)	Single Viscosity	Multi-Viscosity
All Temperatures	—	20W-60 20W-50 15W-50
Below 40°F	SAE 30	10W-30 20W-60 20W-50 15W-50
Above 40°F	SAE 50	20W-60 20W-50 15W-50

An oil filler cap and dipstick are located at the left rear of the engine and are accessible through an access door on the top left side of the engine cowling. The engine should not be operated with less than six quarts of oil. Seven quarts (dipstick indication) is recommended for extended flights.

To check and add oil:

1. Open access door on upper left-hand side of cowl. Pull dipstick and verify oil level.
2. If oil level is below 6 quarts (5.7 liters), remove filler cap and add oil through filler as required to reach 6-8 quarts (5.7-7.6 liters).
3. Verify oil level and install dipstick and filler cap.
4. Close and secure access panel.

Approved Oils

For the first 25 hours of operation (on a new or rebuilt engine) or until oil consumption stabilizes, use only straight mineral oil conforming to Mil-L-6082. If engine oil must be added to the factory installed oil, add only MIL-L-6082 straight mineral oil.

After 25 hours of operation and after oil consumption has stabilized, use only aviation lubricating oils conforming to Lycoming Specifications.

Product	Supplier
Aeroshell (R) W	Shell Australia
Aeroshell Oil W Aeroshell Oil W 15W-50 Anti-Wear Formulation Aeroshell 15W50	Shell Canada Ltd.
Aeroshell Oil W Aeroshell Oil W 15W-50 Anti-Wear Formulation Aeroshell 15W50	Shell Oil Company
Aviation Oil Type A	Phillips 66 Company
BP Aero Oil	BP Oil Corporation
Castrolaero AD Oil	Castrol Ltd. (Australia)
Chevron Aero Oil	Chevron U.S.A. Inc.
Conoco Aero S	Continental Oil
Delta Avoil	Delta Petroleum Co.
Exxon Aviation Oil EE	Exxon Company, U.S.A.
Mobil Aero Oil	Mobil Oil Company
Pennzoil Aircraft Engine Oil	Pennzoil Company
Quaker State AD Aviation Engine Oil	Quaker State Oil & Refining Co.
Red Ram Aviation Oil 20W-50	Red Ram Ltd. (Canada)
Sinclair Avoil	Sinclair Oil Company
Texaco Aircraft Engine Oil – Premium AD	Texaco Inc.
Total Aero DW 15W50	Total France
Turbonycoil 3570	NYCO S.A.
Union Aircraft Engine Oil HD	Union Oil Company of California

Figure 8-1
Approved Oils

Fuel System Servicing

Fuel Filtration Screen/Element

Airplane Serials 3026 thru 3420 before SB 2X-28-08 R1; After the first 25 hours of operation, then every 100-hours or as conditions dictate, the fuel filter element in the gas-collator must be replaced. At every oil change, Verify red pop-up tab on gas-collator is not visible. If tab is visible, the fuel filter element must be replaced and the pop-up tab manually reset.

Airplane Serials 3026 thru 3420 after SB 2X-28-08 R1, 3421 and subsequent; After the first 25 hours of operation, then every 50-hours or as conditions dictate, the fuel filtration screen in the gas-collator must be cleaned. After cleaning, a small amount of grease applied to the gas-collator bowl gasket will facilitate reassembly.

Refer to the Airplane Maintenance Manual for Fuel Screen/Element servicing information.

Fuel Requirements

Aviation grade 100 LL (blue) or 100 (green) fuel is the minimum octane approved for use in this airplane.

Filling Fuel Tanks

Observe all safety precautions required when handling gasoline. Fuel fillers are located on the forward slope of the wing. Each wing holds a maximum of 46.0 U.S. gallons. When using less than the standard 92.1 U.S. gallon capacity, fuel should be distributed equally between each side.

• WARNING •

Have a fire extinguisher available.

Ground fuel nozzle and fuel truck to airplane exhaust pipe and ground fuel truck or cart to suitable earth ground.

Do not fill tank within 100 feet (30.5 meters) of any energized electrical equipment capable of producing a spark.

Permit no smoking or open flame within 100 feet (30.5 meters) of airplane or refuel vehicle.

Do not operate radios or electrical equipment during refuel operations. Do not operate any electrical switches.

To refuel airplane:

1. Place fire extinguisher near fuel tank being filled.
2. Connect ground wire from refuel nozzle to airplane exhaust, from airplane exhaust to fuel truck or cart, and from fuel truck or cart to a suitable earth ground.
3. Place rubber protective cover over wing around fuel filler.

• Note •

Do not permit fuel nozzle to come in contact with bottom of fuel tanks. Keep fuel tanks at least half full at all times to minimize condensation and moisture accumulation in tanks. In extremely humid areas, the fuel supply should be checked frequently and drained of condensation to prevent possible distribution problems.

4. Remove fuel filler cap and fuel airplane to desired level.

• Note •

If fuel is going to be added to only one tank, the tank being serviced should be filled to the same level as the opposite tank. This will aid in keeping fuel loads balanced.

5. Remove nozzle, install filler cap, and remove protective cover.
6. Repeat refuel procedure for opposite wing.
7. Remove ground wires.
8. Remove fire extinguisher.

Fuel Contamination and Sampling

Typically, fuel contamination results from foreign material such as water, dirt, rust, and fungal or bacterial growth. Additionally, chemicals and additives that are incompatible with fuel or fuel system components are also a source of fuel contamination. To assure that the proper grade of fuel is used and that contamination is not present, the fuel must be sampled prior to each flight.

Each fuel system drain must be sampled by draining a cupful of fuel into a clear sample cup. Fuel drains are provided for the fuel gas-collator, wing tanks, and collector tank drains. The gas-collator drain exits the lower engine cowl just forward of the firewall near the airplane centerline. Fuel tank and collector tank drains are located at the low spot in the respective tank.

If sampling reveals contamination, the gas-collator and tank drains must be sampled again repeatedly until all contamination is removed. It is helpful to gently rock the wings and lower the tail slightly to move contaminants to the drain points for sampling. If after repeated samplings (three or more), evidence of significant contamination remains, do not fly the airplane until a mechanic is consulted, the fuel system is drained and purged, and the source of contamination is determined and corrected.

The gas-collator incorporates a filter bypass that activates a red, pop-up tab when pressure drop across the gas-collator reaches 0.8 ± 0.2 PSI. The filter is bypassed when the pressure drop reaches 1.20 ± 0.2 PSI. Once the pop-up tab is activated, the fuel filter element must be replaced and the pop-up tab manually reset. Do not attempt to clean the filter element.

If sampling reveals the airplane has been serviced with an improper fuel grade, do not fly the airplane until the fuel system is drained and refueled with an approved fuel grade.

To help reduce the occurrence of contaminated fuel coming from the supplier or fixed based operator, pilots should assure that the fuel supply has been checked for contamination and that the fuel is properly filtered. Also, between flights, the fuel tanks should be kept as full as operational conditions permit to reduce condensation on the inside of fuel tanks.

Draining Fuel System

The bulk of the fuel may be drained from the wing fuel tanks by the use of a siphon hose placed in the cell or tank through the filler neck. The remainder of the fuel may be drained by opening the drain valves. Use the same precautions as when refueling airplane. Refer to the AMM for specific procedures.

Battery Service

The aircraft is delivered with a maintenance free, rechargeable, sealed, lead acid primary battery. Battery #1 is mounted to the forward right side of the firewall and access is gained by removing the upper cowl. The battery vent is connected to an acid resistant plastic tube that vents gases and electrolyte overflow overboard

A capacity check must be performed at initial 24 months or 1200 hours in service and then every 12 months or 200 hours thereafter. Refer to the AMM for additional information on Battery #1 Overhaul and Replacement Schedule and Scheduled Maintenance Checks.

• Note •

For aircraft equipped with conventional lead acid battery requiring periodic electrolyte level check: Refer to the AMM for information on Battery Overhaul and Replacement Schedule and Scheduled Maintenance Checks

Battery #2 is a maintenance free, rechargeable, sealed, lead acid batter. Mounted in the empennage just aft of bulkhead 222, there is no need to check the specific gravity of the electrolyte or add water to these batteries during their service life. Refer to the AMM for Overhaul and Replacement Schedule.

The external power receptacle is located on the left side of the fuselage just aft of the firewall. Refer to the AMM for battery servicing procedures.

Cleaning and Care

Cleaning Exterior Surfaces

• Caution •

Airplane serials with Ice Protection System; Do not wax leading edge porous panels. Refer to Section 9, Supplements for specific servicing information on the Ice Protection System.

• Note •

Prior to cleaning, place the airplane in a shaded area to allow the surfaces to cool.

The airplane should be washed with a mild soap and water. Harsh abrasives or alkaline soaps or detergents could make scratches on painted or plastic surfaces or could cause corrosion of metal. Cover static ports and other areas where cleaning solution could cause damage. Be sure to remove the static port covers before flight. To wash the airplane, use the following procedure:

1. Flush away loose dirt with water.
2. Apply cleaning solution with a soft cloth, a sponge or a soft bristle brush.
3. To remove exhaust stains, allow the solution to remain on the surface longer.
4. To remove stubborn oil and grease, use a cloth dampened with naphtha.
5. Rinse all surfaces thoroughly.

Any good silicone free automotive wax may be used to preserve painted surfaces. Soft cleaning cloths or a chamois should be used to prevent scratches when cleaning or polishing. A heavier coating of wax on the leading surfaces will reduce the abrasion problems in these areas.

Cleaning Product	Cleaning Application	Supplier
Pure Carnauba Wax	Fuselage Exterior	Any Source
Mothers California Gold Pure Carnauba Wax	Fuselage Exterior	Wal-Mart Stores
RejeX	Fuselage Exterior	Corrosion Technologies
WX/Block System	Fuselage Exterior	Wings and Wheels
AeroShell Flight Jacket Plexicoat	Fuselage Exterior	ShellStore Online
XL-100 Heavy-Duty Cleaner/Degreaser	Fuselage Exterior and Landing Gear	Buckeye International
Stoddard Solvent PD-680 Type II	Engine Compartment	Any Source
Kerosene	Exterior Windscreen and Windows	Any Source
Klear-To-Land	Exterior Windscreen and Windows	D.W. Davies & Co
Prist	Exterior Windscreen and Windows	Prist Aerospace
LP Aero Plastics Acrylic Polish & Sealant	Exterior Windscreen and Windows	Aircraft Spruce & Specialty

Figure 8-2
Recommended Exterior Cleaning Products

Windscreen and Windows

Before cleaning an acrylic window, rinse away all dirt particles before applying cloth or chamois. Never rub dry acrylic. Dull or scratched window coverings may be polished using a special acrylic polishing paste.

• Caution •

Clean acrylic windows with a solvent free, none abrasive, antistatic acrylic cleaner. Do not use gasoline, alcohol, benzene, carbon tetrachloride, thinner, acetone, or glass window cleaning sprays.

Use only a nonabrasive cotton cloth or genuine chamois to clean acrylic windows. Paper towel or newspaper are highly abrasive and will cause hairline scratches.

1. Remove grease or oil using a soft cloth saturated with kerosene then rinse with clean, fresh water.

• Note •

Wiping with a circular motion can cause glare rings. Use an up and down wiping motion to prevent this.

To prevent scratching from dirt that has accumulated on the cloth, fold cloth to expose a clean area after each pass.

2. Using a moist cloth or chamois, gently wipe the windows clean of all contaminants.
3. Apply acrylic cleaner to one area at a time, then wipe away with a soft, cotton cloth.
4. Dry the windows using a dry nonabrasive cotton cloth or chamois.

Enhanced Vision System Sensor Windows (Optional)

The Enhanced Vision System Sensor is located on the underside of the LH wing. The three sensor windows are made of Germanium. In contrast to visible light energy, infrared energy typically passes through dirt on the window. As such, the Sensor windows requires only occasional cleaning with mild liquid soap and water or isopropyl alcohol, and a soft cloth.

• Caution •

If a EVS Sensor Window breaks, use gloves and masks when handling broken germanium window material.

Do not use abrasive cleansers or cleaning pads on the germanium window. Abrasive cleaning can damage the sensor window coating.

Do not use any cleansers containing ammonia. Ammonia will remove the sensor window coating.

Engine Compartment

Before cleaning the engine compartment, place a strip of tape on the magneto vents to prevent any solvent from entering these units.

1. Place a large pan under the engine to catch waste.
2. Remove induction air filter and seal off induction system inlet.
3. With the engine cowling removed, spray or brush the engine with solvent or a mixture of solvent and degreaser. In order to remove especially heavy dirt and grease deposits, it may be necessary to brush areas that were sprayed.

• Caution •

Do not spray solvent into the alternator, vacuum pump, starter, or induction air intakes.

4. Allow the solvent to remain on the engine from 5 to 10 minutes. Then rinse engine clean with additional solvent and allow it to dry.

• Caution •

Do not operate the engine until excess solvent has evaporated or otherwise been removed.

5. Remove the protective tape from the magnetos.
6. Open induction system air inlet and install filter.
7. Lubricate in accordance with the Lubrication Chart.

Landing Gear

Before cleaning the landing gear, place a plastic cover or similar material over the wheel and brake assembly.

1. Place a pan under the gear to catch waste.
2. Spray or brush the gear area with solvent or a mixture of solvent and degreaser, as desired. Where heavy grease and dirt deposits have collected, it may be necessary to brush areas that were sprayed, in order to clean them.

3. Allow the solvent to remain on the gear from five to ten minutes. Then rinse the gear with additional solvent and allow to dry.
4. Remove the cover from the wheel and remove the catch pan.
5. Lubricate the gear in accordance with the Lubrication Chart.

Cleaning Interior Surfaces

Seats, carpet, upholstery panels, and headliners should be vacuumed at regular intervals to remove surface dirt and dust. While vacuuming, use a fine bristle nylon brush to help loosen particles.

• Caution •

Remove any sharp objects from pockets or clothing to avoid damaging interior panels or upholstery.

Windshield and Windows

Never rub dry acrylic. Dull or scratched window coverings may be polished using a special acrylic polishing paste.

• Caution •

Clean acrylic windows with a solvent free, none abrasive, antistatic acrylic cleaner. Do not use gasoline, alcohol, benzene, carbon tetrachloride, thinner, acetone, or glass window cleaning sprays.

Use only a nonabrasive cotton cloth or genuine chamois to clean acrylic windows. Paper towel or newspaper are highly abrasive and will cause hairline scratches.

• Note •

Wiping with a circular motion can cause glare rings. Use an up and down wiping motion to prevent this.

To prevent scratching from dirt that has accumulated on the cloth, fold cloth to expose a clean area after each pass.

1. Using a moist cloth or chamois, gently wipe the windows clean of all contaminants.
2. Apply acrylic cleaner to one area at a time, then wipe away with a soft, cotton cloth.
3. Dry the windows using a dry nonabrasive cotton cloth or chamois.

Cleaning Product	Cleaning Application	Supplier
Prist	Interior Windscreen and Windows	Prist Aerospace
Optimax	Display Screens	PhotoDon
Mild Dishwasher Soap (abrasive free)	Cabin Interior	Any Source
Leather Care Kit 50689-001	Leather Upholstery	ATPI Design
Leather Cleaner 50684-001	Leather Upholstery	ATPI Design
Ink Remover 50685-001	Leather Upholstery	ATPI Design
Leather Conditioner 50686-001	Leather Upholstery	ATPI Design
Spot and Stain Remover 50687-001	Leather Upholstery	ATPI Design
Vinyl Finish Cleaner 50688-001	Vinyl Panels	ATPI Design
Vinyl & Leather Cleaner 51479-001	Vinyl and Leather Upholstery	ATPI Design

Figure 8-3
Recommended Interior Cleaning Products

Instrument Panel and Electronic Display Screens

The instrument panel, control knobs, and plastic trim need only to be wiped clean with a soft damp cloth. The multifunction display, primary flight display, and other electronic display screens should be cleaned with Optimax - LCD Screen Cleaning Solution as follows:

• Caution •

To avoid solution dripping onto display and possibly migrating into component, apply the cleaning solution to cloth first, not directly to the display screen.

Use only a lens cloth or nonabrasive cotton cloth to clean display screens. Paper towels, tissue, or camera lens paper may scratch the display screen.

Clean display screen with power OFF.

1. Gently wipe the display with a clean, dry, cotton cloth.
2. Moisten clean, cotton cloth with cleaning solution.
3. Wipe the soft cotton cloth across the display in one direction, moving from the top of the display to the bottom. Do not rub harshly.
4. Gently wipe the display with a clean, dry, cotton cloth.

Headliner and Trim Panels

The airplane interior can be cleaned with a mild detergent or soap and water. Harsh abrasives or alkaline soaps or detergents should be avoided. Solvents and alcohols may damage or discolor vinyl or urethane parts. Cover areas where cleaning solution could cause damage. Use the following procedure:

• Caution •

Solvent cleaners and alcohol should not be used on interior parts. If cleaning solvents are used on cloth, cover areas where cleaning solvents could cause damage.

1. Clean headliner, and side panels, with a stiff bristle brush, and vacuum where necessary.
2. Soiled upholstery, may be cleaned with a good upholstery cleaner suitable for the material. Carefully follow the manufacturer's instructions. Avoid soaking or harsh rubbing.

Leather Upholstery and Seats

For routine maintenance, occasionally wipe leather upholstery with a soft, damp cloth. For deeper cleaning, start with mix of mild detergent and water then, if necessary, work your way up to the products available from ATPI for more stubborn marks and stains. Do not use soaps as they contain alkaline which will alter the leather's pH balance and cause the leather to age prematurely. Cover areas where cleaning solution could cause damage. Use the following procedure:

• Caution •

Solvent cleaners and alcohol should not be used on leather upholstery.

1. Clean leather upholstery with a soft bristle brush, and vacuum where necessary.
2. Wipe leather upholstery with a soft, damp cloth.
3. Soiled upholstery, may be cleaned with the approved products available from ATPI Design. Avoid soaking or harsh rubbing.

Carpets

To clean carpets, first remove loose dirt with a whiskbroom or vacuum. For soiled spots and stubborn stains use a non-flammable, dry cleaning fluid. Floor carpets may be cleaned like any household carpet.

Section 9 Supplements

This section of the handbook contains FAA Approved Supplements necessary to safely and to efficiently operate the aircraft when equipped with optional systems or equipment not provided with the standard airplane or for special operations or not included in the handbook. Basically, supplements are mini-handbooks and will contain data corresponding to most sections of the handbook. Data in a supplement adds to, supersedes, or replaces similar data in the basic handbook.

A Log of Supplements page immediately follows this page and precedes all ATPI Design Supplements produced for this airplane. The Log of Supplements page can be utilized as a "Table of Contents" for this section. In the event the airplane is modified at a non ATPI Design facility through an STC or other approval method, it is the owner's responsibility to assure that the proper supplement, if applicable, is installed in the handbook and the supplement is properly recorded on the Log of Supplements page.

FAA Approved POH Supplements must be in the airplane for flight operations when the subject optional equipment is installed or the special operations are to be performed.

• Note •

This Log of Supplements shows all ATPI Design Supplements available for the aircraft at the corresponding date of the revision level shown in the lower left corner. A mark (x) in the Part Number column indicates that the supplement is installed in the POH.

Intentionally Left Blank

Section 9

Log of Supplements

Part Number	Title	Date
___ 13772-109 R2	Approved Oxygen Systems	01-06-10
___ 13772-115 R9	Basic Ice Protection System	12-17-10
___ 13772-114 R1 T1 / T1T	Airplanes Registered in Canada	07-07-10
___ 13772-119 T1	Airplanes Registered in Israel	12-03-03
___ 13772-122 R1 T1 / T1T	Airplanes Registered in European Union	07-07-10
___ 13772-129 R2	Hartzell Compact Series Propeller w/ Composite Blades	08-26-09
___ 13772-131 R2	Artex ME406 406 MHz ELT System	01-06-10
___ 13772-134 R4	TKS Anti-Ice System	12-17-10
___ 13772-135 R3	GFC 700 Automatic Flight Control System	12-14-10
___ 13772-136 R1	Garmin Terrain Awareness/Warning System	01-06-10
___ 13772-140 R1	S-Tec Fifty Five X Autopilot w/ Optional Flight Director	01-06-10
___ 13772-141 R1	S-Tec Fifty Five SR Autopilot	01-06-10
___ 13772-142 T1	Airplanes Registered in Russia	10/14/09
___ 13772-143 R2	Part 135 Electrical Loading Shedding Procedure	01-06-10
___ 13772-145 T1	Airplanes Registered in Argentina	09-30-09
___ 13772-147 T1 / T1T	Airplanes Registered in Colombia	10-07-10

FAA Approved POH Supplements must be in the airplane for flight operations when the subject optional equipment is installed or the special operations are to be performed.

This Log of Supplements shows all ATPI Design Supplements available for the aircraft at the corresponding date of the revision level shown in the lower left corner. A mark (x) in the Part Number column indicates that the supplement is installed in the POH.

**Pilot's Operating Handbook and
FAA Approved Airplane Flight Manual
Supplement
for the**

Basic Ice Protection System

When the Basic Ice Protection System is installed on the aircraft, this POH Supplement is applicable and must be inserted in the Supplements Section of the Pilot's Operating Handbook. This document must be carried in the airplane at all times. Information in this supplement adds to, supersedes, or deletes information in the basic Pilot's Operating Handbook.

• Note •

Noted effectivity "*Serials with G3 Wing*" indicates Serials 22-2334, 22-2420, 22-2438 and subsequent, 22T-0001 and subsequent.

Noted effectivity "*Serials before G3 Wing*" indicates Serials 22-0334 thru 22-2333, 22-2335 thru 22-2419, 22-2421 thru 22-2437 unless otherwise noted.

This POH Supplement Change, dated Revision 09: 12-17-10, supersedes and replaces revision 08 of this POH Supplement dated 01-06-10.

FAA Approved

Joseph C. Miss

Dec 17 2010
Date _____

for Charles Smalley, Manager
Chicago Aircraft Certification Office, ACE-115C
Federal Aviation Administration

Section 1 - General

The airplane is equipped with an Ice Protection System. This system allows a pilot who inadvertently enters icing conditions, to initiate de-icing fluid flow along the wing, horizontal stabilizer, and propeller blades.

Section 2 - Limitations

The Ice Protection System is certified only as “No Hazard” to normal operations, therefore, no determination has been made as to the capability of this system to remove or prevent ice accumulation

1. Flight into known icing is prohibited.
2. Deicing Fluid must meet British Specification DTD 406B.

Placards

*Serials 22-0334 thru 22-2333, 22-2335 thru 22-2419, 22-2421 thru 22-2437;
LH Fuselage, above de-icing fluid filler cap:
Serials 22-2334, 22-2420, 22-2438 & subs, 22T-0001 & subs;
Left wing, above de-icing fluid filler cap:*

**DE-ICING FLUID
REFER TO AFM FOR APPROVED
DE-ICING FLUIDS**

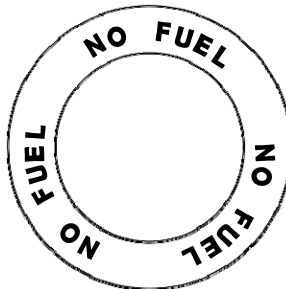

T1_FM09_2592A

**Figure - 1
Required Placards**

Section 3 - Emergency Procedures

Inadvertent Icing Encounter

• **WARNING** •

The Ice Protection System may not remove significant accumulations of ice if accretions are permitted to form with the system off. Ensure system start time and system mode is noted while exiting icing conditions to aid in estimating ice protection fluid quantity.

Flight into known icing conditions is prohibited. However, if icing is inadvertently encountered determine the most appropriate operating mode:

NORMAL mode is selected when icing conditions are encountered prior to ice accretion. The maximum system operating time while in NORMAL mode is approximately;

Serials before G3 Wing; 60 minutes.

Serials with G3 Wing; 80 minutes.

MAXIMUM mode is selected if ice has accreted to flight surfaces. The maximum system operating time while in MAXIMUM mode is approximately;

Serials before G3 Wing; 30 minutes.

Serials with G3 Wing; 40 minutes.

1. Ice Protection System As required
2. PITOT HEAT ON
3. Airspeed 95-139 KIAS (175 KTAS)
4. Time NOTED
5. Exit icing conditions. Turn back and/or change altitude.
6. Cabin Heat MAXIMUM
7. Windshield Defrost FULL OPEN
8. Alternate Induction Air ON
9. When Icing Conditions Cleared, Ice Protection System OFF
10. Airspeed As flight conditions dictate

Section 3A - Abnormal Procedures

The following Crew Alerting System (CAS) annunciations are available only on *aircraft equipped with the ATPI Integrated Avionics System*.

Ice Protection System CAS Annunciation

Low Fluid Quantity Warning, Caution, and Advisory

ANTI ICE QTY

PFD Alerts Window: "Fluid quantity is low (TKS)"

ANTI ICE QTY Warning: System in ON and Fluid Quantity is less than 0.5 gallon. (1.9 L).

ANTI ICE QTY Caution: System in ON and Fluid Quantity is between 0.5 - 1.0 gallon (1.9 - 3.8 L).

ANTI ICE QTY Advisory: System in OFF and Fluid Quantity is less than or equal to 1.0 gallon (3.8 L).

1. Ice Protection System..... MONITOR
2. Fluid Quantity.....MONITOR, SERVICE AS REQUIRED

Section 4 - Normal Procedures

• Caution •

Prolonged operation of the system in clear air, at very high altitudes, and very cold temperatures can result in “flash” evaporation of water and alcohol from the de-icing fluid. This evaporation results in a glycol rich fluid that could become “gel” like on the wing surface until the aircraft enters cloud or descends to warmer temperatures.

• Note •

The Ice Protection System is approved for operation with ice protection fluid that has a very temperature-dependent viscosity characteristic. As the temperature of the fluid rises above freezing (32F / 0C), the fluid becomes much less viscous (thins) and pass through the porous membrane of the panels with less resistance (pressure drop). This decrease in pressure drop reduces the pressure in the panel reservoir which may not be adequate to wet-out the entire panel if the Pre-Flight Inspection is performed at warmer temperatures.

Pre-Flight Inspection

1. Cabin
 - a. Circuit Breakers SET
 - b. Battery 1 Master Switch ON
 - c. Ice Protection System Mode.....HIGH/MAXIMUM
2. Empennage
 - a. *Serials before G3 Wing;*
Fluid Tank VERIFY DESIRED QUANTITY
 - b. Stabilizer Porous Panels.....CONDITION / SECURITY
 - (1) Verify Evidence of Deicing Fluid Along Length of Panels.
3. Right Wing Forward and Main Gear
 - a. Wing Porous PanelsCONDITION / SECURITY
 - (1) Verify Evidence of Deicing Fluid Along Length of Panels.
4. Nose Gear, Propeller, Spinner

- a. Slinger Ring..... EVIDENCE OF DEICING FLUID
- 5. Left Wing Forward and Main Gear
 - a. *Serials with G3 Wing;*
 - (1) Fluid Tank..... VERIFY DESIRED QUANTITY
 - (a) Filler CapCONDITION / SECURITY
 - (b) Vent (underside of wing) UNOBSTRUCTED
 - b. Wing Porous PanelsCONDITION / SECURITY
 - (1) Verify Evidence of Deicing Fluid Along Length of Panels.
- 6. Cabin
 - a. *Serials w/ Integrated Avionics:*
 - (1) Fluid Quantity..... CHECK
- 7. Ice Protection System..... OFF
- 8. BAT 1 Switch..... OFF

Section 5 - Performance

Cruise speed is lower by approximately three knots and range is reduced by a maximum of 2%.

Experience with your airplane's power settings may result in more accurate performance numbers than those given above.

1. Reduce KTAS shown on the Cruise Performance tables and the Range/Endurance Profile tables by 3 knots.
2. Reduce range shown on the Range/Endurance Profiles by 2%.

• Caution •

During certain flight conditions, such as at higher operating altitudes and/or higher airspeeds, the stagnation point on the leading edge of the wing (the point where the airflow splits) will move up and aft enough to hinder the deicing fluid from flowing adequately along the top surface of the wing. Airspeed for optimum system performance is 95-139 KIAS. Do not exceed 175 KTAS above 14000 ft.

Section 6 - Weight & Balance

Refer to Section 6 - Weight and Balance of the basic POH for current weight and balance data. Use the following table to determine the Moment/1000 for deicing fluid to complete the Loading Form in the Weight and Balance Section of the basic POH.

Serials before G3 Wing; Total fluid tank capacity is 2.9 gal. (10.9 L).

Serials with G3 Wing; Total fluid tank capacity is 3.5 gallons (13.2 L).

Deicing fluid weight is 9.2 pounds per gallon.

Loading Data - *Serials before G3 Wing*

Gallons	Weight LB	Mom/ 1000@ Fluid Tank (FS181.0)	Gallons	Weight LB	Mom/ 1000@ Fluid Tank (FS181.0)
0.1	0.9	0.17	2.1	19.3	3.50
0.2	1.8	0.33	2.2	20.2	3.66
0.3	2.8	0.50	2.3	21.2	3.83
0.4	3.7	0.67	2.4	22.1	4.00
0.5	4.6	0.83	2.5	23.0	4.16
0.6	5.5	1.00	2.6	23.9	4.33
0.7	6.4	1.17	2.7	24.8	4.50
0.8	7.4	1.33	2.8	25.8	4.66
0.9	8.3	1.50	2.9*	26.7	4.83
1.0	9.2	1.67	*2.9 gallon (10.9 L) Capacity.		
1.1	10.1	1.83			
1.2	11.0	2.00			
1.3	12.0	2.16			
1.4	12.9	2.33			
1.5	13.8	2.50			
1.6	14.7	2.66			
1.7	15.6	2.83			
1.8	16.6	3.00			
1.9	17.5	3.16			
2.0	18.4	3.33			

Loading Data - Serials with G3 Wing

Gallons	Weight LB	Mom/ 1000@ Fluid Tank (FS148.0)	Gallons	Weight LB	Mom/ 1000@ Fluid Tank (FS148.0)
0.1	0.9	0.14	3.0	27.6	4.08
0.2	1.8	0.27	3.1	28.5	4.22
0.3	2.8	0.41	3.2	29.4	4.36
0.4	3.7	0.54	3.3	30.4	4.49
0.5	4.6	0.68	3.4	31.3	4.63
0.6	5.5	0.82	3.5*	32.2	4.77
0.7	6.4	0.95	*3.5 gallon (13.2 L) Capacity.		
0.8	7.4	1.09			
0.9	8.3	1.23			
1.0	9.2	1.36			
1.1	10.1	1.50			
1.2	11.0	1.63			
1.3	12.0	1.77			
1.4	12.9	1.91			
1.5	13.8	2.04			
1.6	14.7	2.18			
1.7	15.6	2.31			
1.8	16.6	2.45			
1.9	17.5	2.59			
2.0	18.4	2.72			
2.1	19.3	2.86			
2.2	20.2	3.00			
2.3	21.2	3.13			
2.4	22.1	3.27			
2.5	23.0	3.40			
2.6	23.9	3.54			
2.7	24.8	3.68			
2.8	25.8	3.81			
2.9	26.7	3.95			

Section 7 - System Description

The Ice Protection System can prevent, and in certain conditions, remove ice accumulation on the flight surfaces by distributing a thin film of glycol-based fluid on the wing, horizontal stabilizer, and propeller. The presence of this fluid lowers the freezing temperature on the flight surface below that of the ambient precipitation preventing the formation and adhesion of ice.

Ice Protection System - *Serials before G3 Wing*

The system consists of six porous panels, propeller slinger ring, four proportioning units, metering pump, filter, outlet strainer, fluid tank, filler cap, electrical switching, and system plumbing. The system operates on 28 VDC supplied through the 5-amp ICE PROTECTION circuit breaker on Main Bus 1.

Storage and Distribution

The deicing fluid tank is serviced through a filler located on the LH side of the fuselage, just forward of the baggage door. The fluid tank, located behind the LH rear cabin trim panel, has a total capacity of 2.96 gallons (11.2L). A fine-mesh outlet strainer mounted internal to the tank protects the metering pump from damage by contaminants.

Upon activation, a two-speed metering pump, mounted below the LH passenger seat, draws fluid from the tank and provides fluid pressure to the system at a constant-volume flow rate. Low pump speed provides the required flow during NORMAL operation and high pump speed during MAXIMUM operation. The manifold of the Metering Pump is primed by actuating the gravity-fed Drain Valve located on the lower fuselage skin.

From the metering pump, deicing fluid is pushed through a filter, mounted adjacent to the pump, and then carried to the proportioning units located in the wing, empennage, and cabin floor-forward through nylon tubing.

- The LH and RH Wing proportioning units distributes fluid to the Inboard and Outboard wing panels.
- The empennage proportioning unit distributes fluid to the LH and RH horizontal panels.

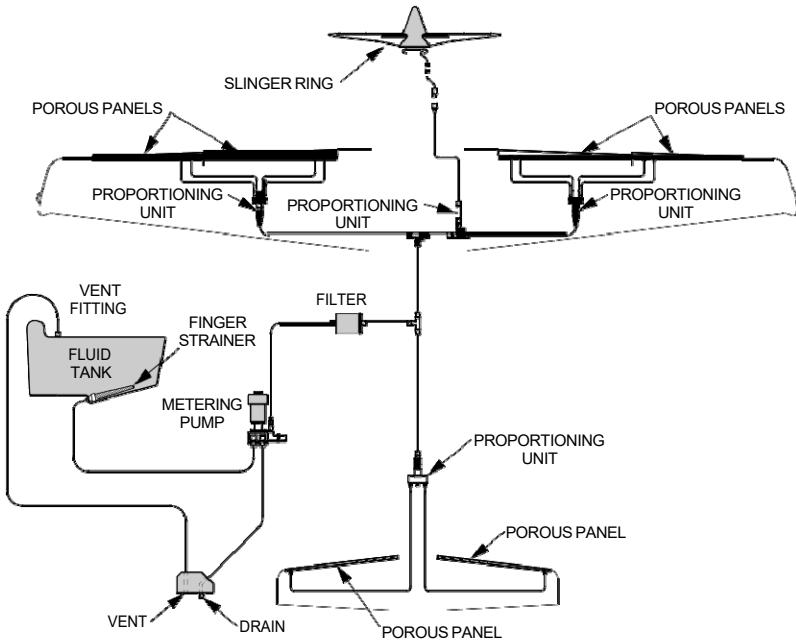

T1_FM09_1527

Figure - 2
System Schematic - Serials before G3 Wing

- A cabin floor-forward proportioning unit distributes fluid to the propeller slinger ring assembly.

In addition to distributing fluid to the porous panels and propeller slinger ring, the proportioning units provide an additional, distinct pressure drop to the supply lines such that a specific flow rate is provided to each protected surface. Small, flap-type check valves positioned on the outlet of each proportioning unit port prevent the back-flow of fluid from the associated panel

Porous Panels

The proportioned fluid enters the leading edge panels through the inlet fitting(s) on the inboard end of the wing panels, and outboard end of the horizontal panels. The outer surface of the panels is perforated with very small openings to distribute the deicing fluid along their entire length. The panels contain a porous membrane whose pores are nearly 100 times smaller than the openings of the outer surface. The leading edge panel serves as a reservoir as fluid entering the panel fills the cavity behind the porous membrane then overcomes this resistance to be distributed by the openings in the external surface. Each panel incorporates a vent opposite the inlet which provides a relatively large opening to release air from within the panel. A check valve prevents air from entering the panel through the vent which slows the "leak-down" of the panel during periods of inactivity.

Propeller Slinger Ring

Deicing fluid protects the propeller by a slinger ring mounted to the spinner backing plate where the fluid is distributed by centrifugal action onto grooved rubber boots fitted to the root end of the propeller blades.

System Control

System operation is controlled by, *Serials 22-0334 thru 22-0434*; a three-position switch mounted on the center console panel which allows the user to select OFF, NORMAL, or MAXIMUM positions. *Serials 22-0435 & subs*; two switches located on the bolster panel. The first switch controls system operation through ON and OFF positions, the second switch controls the system mode (flow rate) through NORMAL and HIGH positions.

Ice Protection System - *Serials with G3 Wing*

The system consists of six porous panels, propeller slinger ring, two proportioning units, metering pump, priming pump, filter, in-line strainer, fluid tank, filler cap and neck, test port assembly, electrical switching, system plumbing, and (Serials w/ Integrated Avionics) deicing fluid level sensor. The system operates on 28 VDC supplied through 5-amp ICE PROTECTION circuit breaker on Main Bus 1.

Storage and Distribution

The 3.5 gallons (13.2L) deicing fluid tank is serviced through a filler located on the upper LH wing skin. The tank is a sealed wet bay, integral to the wing structure, bounded by the upper and lower wing skins, main spar web, and the inboard, outboard, and lateral tank ribs. The tank is vented from the outboard rib to a NACA style duct attached to an access panel on the lower wing skin, just outboard of the tank. A course-mesh outlet strainer mounted internal to the tank prevents large objects from obstructing the tank outlet, while a fine-mesh in-line strainer protects the metering pump and priming pump from damage by contaminants.

Upon activation, a two-speed metering pump, mounted below the LH passenger seat, draws fluid from the tank and provides fluid pressure to the system at a constant-volume flow rate. Low pump speed provides the required flow during NORMAL operation and high pump speed during HIGH/MAXIMUM operation. The manifold of the metering pump is primed by an integral priming pump which draws fluid through the manifold and returns it to the tank. A check valve between the priming pump and the tank prevents back-flow of fluid to the metering pump. The priming pump operates for the first 10 seconds of system operation. In the event of the loss of prime, the priming pump can be activated to draw fluid from the tank to prime the metering pump manifold.

From the metering pump, deicing fluid is pushed through a filter, mounted adjacent to the pump, and then carried through nylon tubing to the proportioning units located in the cabin floor-forward and empennage.

- The cabin floor-forward proportioning unit distributes fluid to the LH and RH Wing Inboard and Outboard panels and propeller slinger ring assembly.

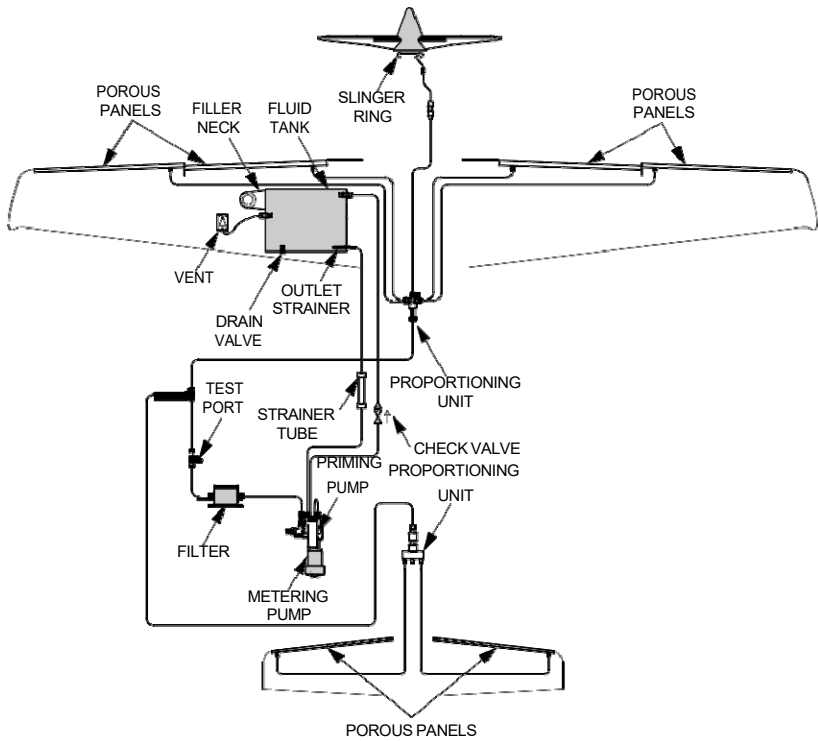

T1_FM09_2591

Figure - 3
System Schematic - Serials with G3 Wing

- The empennage proportioning unit distributes fluid to the LH and RH horizontal panels.

In addition to distributing fluid to the porous panels and propeller slinger ring, the proportioning units provide an additional, distinct pressure drop to the supply lines such that a specific flow rate is provided to each protected surface. Small, flap-type check valves positioned on the outlet of each proportioning unit port prevent the back-flow of fluid from the associated panel.

Porous Panels

The proportioned fluid enters the leading edge panels through the inlet fitting(s) on the inboard end of the wing panels, and outboard end of the horizontal panels. The outer surface of the panels is perforated with very small openings to distribute the deicing fluid along their entire length. The panels contain a porous membrane whose pores are nearly 100 times smaller than the openings of the outer surface. The leading edge panel serves as a reservoir as fluid entering the panel fills the cavity behind the porous membrane then overcomes this resistance to be distributed by the openings in the external surface. The inlet fitting of the Inboard wing porous panel also supplies fluid to the porous stall strip through an additional capillary tube which further proportions the fluid to provide a specific flow rate to the stall strip. Each panel incorporates a vent opposite the inlet which provides a relatively large opening to release air from within the panel. A check valve prevents air from entering the panel through the vent which slows the "leak-down" of the panel during periods of inactivity.

Propeller Slinger Ring

Deicing fluid protects the propeller by a slinger ring mounted to the spinner backing plate where the fluid is distributed by centrifugal action onto grooved rubber boots fitted to the root end of the propeller blades.

System Control

System operation is controlled by two switches located on the bolster panel. The first switch controls system operation through ON and OFF positions, the second switch controls the system mode (flow rate) through NORMAL and HIGH positions.

Fluid Quantity Sensing

Serials w/ Integrated Avionics: Fluid quantity is measured by a float type quantity sensor installed in the deicing fluid tank.

System Indicating

Serials w/ Integrated Avionics: System Indicating is displayed as a dial gauge and text in the lower left corner of the MFD ENGINE page. A dial gage marked from 0 to 3.5 U.S. gallons, in 0.5 gallon increments indicates the tank fluid quantity. Fluid quantity is also displayed numerically below the dial gauge in 0.1 gallon increments.

Section 8 – Handling, Service, & Maintenance

• Caution •

During long periods of non-use, the porous panel membranes may dry out which could cause uneven fluid flow during subsequent operation. Perform the Pre-Flight Inspection every 30 days to keep porous panel membranes wetted.

Use only approved deicing fluid. See Section 2, Limitations. To prevent fluid contamination, maintain a clean, dedicated measuring container and ensure mouth of fluid container is clean before dispensing. Secure the filler cap immediately after filling

Certain solvents may damage the panel membrane. Use only soap and water, isopropyl alcohol, or ethyl alcohol to clean panels. Do not wax leading edge porous panels.

Storage

To prepare the Ice Protection System for flyable storage, fill the deicing fluid tanks and perform the Pre-Flight Inspection to verify evidence of ice protection fluid along the length of all porous panels. The tanks may then be drained until the next service interval (30 days minimum) or operation of the system is desired.

Servicing

De-Icing Fluid Tank

Serials before G3 Wing: The ice protection fluid tank is serviced through a filler cap located on the LH side of the fuselage, just forward of the baggage door. The tank is drained by actuating the Drain Valve on the lower LH side of fuselage skin, just forward of fluid tank.

Serials w/ G3 Wing: The ice protection fluid tank is serviced through a filler cap located on the upper LH wing skin. The tank is drained by a lock-open/lock-close drain valve, located on an access panel in the lower LH wing skin.

Porous Panels

Periodically clean porous panels with soap and water using a clean, lint-free cloth. Isopropyl alcohol may be used to remove oil or grease.

Metering Pump Priming - Serials before G3 Wing

If air enters the system due to the fluid tank running dry during system operation, the metering pump may not be capable of priming itself. To draw fluid from the tank to prime the metering pump manifold and remove any entrapped air between the metering pump and the fluid tank:

1. Locate de-icing fluid drain on LH side of fuselage belly just forward of fluid tank.
2. Sample de-icing fluid until fluid stream shows no evidence of air bubbles for at least three seconds.
3. Set ICE PROTECT Mode Switch to MAXIMUM and verify evidence of fluid at each of the protected locations.
4. If necessary, repeat steps 2 and 3

Metering Pump Priming - Serials with G3 Wing

If air entered the system due to the fluid tank running dry during system operation, it may require several cycles of the priming pump to prime the metering pumps.

In the event that the metering pump cannot prime itself, the priming pump may be activated by cycling the ICE PROTECT System Switch, 10s ON, 10s OFF, to draw fluid from the tank to prime the metering pump manifold and remove any entrapped air between the metering pump and the fluid tank.

System Priming

For optimal performance, the system should be primed on the ground by performing the preflight inspection to verify all protected surfaces wet-out fully.

Section 10 – Safety Information

The Ice Protection System is not intended to remove ice from the aircraft on the ground. Do not attempt to take off with frost, ice, or snow on flying surfaces.

Flight into known icing is prohibited. The Ice Protection System has not been evaluated in known icing conditions. Therefore, the effects of known icing on the system is unknown. Its purpose is to provide some protection from the effects of ice, should an unexpected encounter with icing conditions occur. At the first indication of icing, the most expeditious and safest course of exiting the icing conditions should be taken. The decision should be based on weather briefings, recent pilot reports, ATC observations, and may include course changes or altitude changes.

During simulated icing encounters, stall speed increases of approximately 12 knots in the clean configuration and 3 knots in the landing configuration were observed. In addition, cruise speed was reduced by at least 20 KCAS and the airplanes rate of climb diminished by at least 20%.

Even with the protected flight surfaces totally clear of ice, performance degradation will occur due to ice on unprotected regions. The amount of the degradation cannot be accurately predicted and it is therefore, depending on circumstances, advisable to increase approach and landing speeds while using the Ice Protection System. Use extreme caution during approach and landing, being alert to the first signs of pre-stall buffet and an impending stall.

Pilot's Operating Handbook and
FAA Approved Airplane Flight Manual
Supplement
for

Artex ME406 406 MHz ELT System

When Artex ME406 406 MHz ELT System is installed on the aircraft, this POH Supplement is applicable and must be inserted in the Supplements Section of the Pilot's Operating Handbook. This document must be carried in the airplane at all times. Information in this supplement adds to, supersedes, or deletes information in the basic Pilot's Operating Handbook.

This POH Supplement Change, dated Revision 02: 01-06-10, supersedes and replaces the Revision 01 release of this POH Supplement dated 05-13-08.

FAA Approved

Handwritten signature of Joseph C. Miss in black ink.Date Jan 06 2010

for Charles Smalley, Manager
Chicago Aircraft Certification Office, ACE-115C
Federal Aviation Administration

Section 1 - General

The 406 MHz emergency locator transmitter (ELT) is a radio-frequency transmitter that generates a signal to assist in search and rescue for missing aircraft. The ELT automatically transmits the standard sweep tone on 121.5 MHz if rapid deceleration is detected. In addition, for the first 24 hours of operation, a 406 MHz signal containing aircraft specific information is transmitted at 50 seconds for 440 milliseconds.

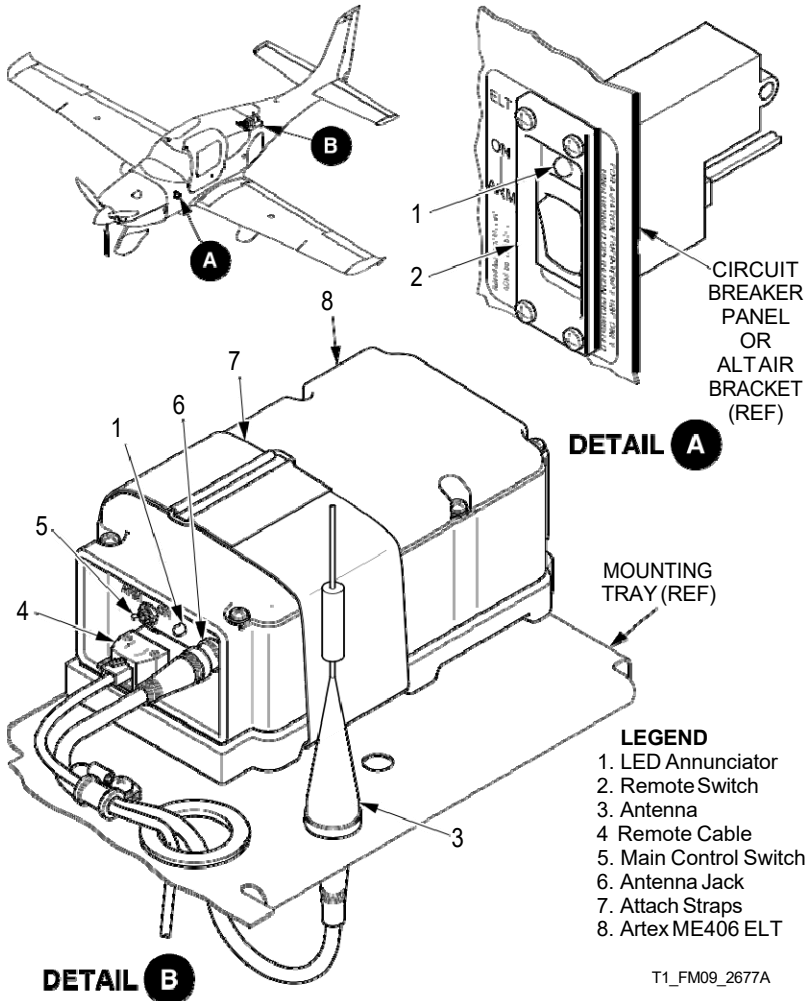

Figure - 1
Artex ME406 ELT System

Section 2 - Limitations

No Change.

Section 3 - Emergency Procedures

Forced Landing

Before performing a forced landing activate the ELT transmitter manually by turning the ELT remote switch to the 'ON'-position. Immediately after a forced landing, perform the following procedure:

• Note •

The ELT Remote Switch and Control Panel Indicator could be inoperative in the event of a forced landing. If inoperative, the inertia "G" switch will activate automatically. However, to turn the ELT OFF and ON will require manual switching of the main control switch located on the ELT unit.

1. ELT Remote SwitchVerify ON
 - Switch the ELT Remote Switch ON even if the red LED annunciator is flashing.
 - If airplane radio operable and can be safely used (no threat of fire or explosion), turn radio ON and select 121.5 MHz. If the ELT can be heard transmitting, it is working properly.
2. Battery PowerConserve
 - Do not use radio transceiver until rescue aircraft is sighted.

After sighting rescue aircraft:

3. ELT Remote Switch "ARM" position
to prevent radio interference.
 - Attempt contact with rescue aircraft with the radio transceiver set to a frequency of 121.5 MHz. If no contact is established, switch the panel mounted switch to the 'ON'-position immediately.

(Continued on following page)

Portable Use of ELT

The ELT transmitter can be removed from the airplane and used as a personal locating device if it is necessary to leave the airplane after an accident. Access the unit as described below and set the ELT transmitter control switch to the 'ON'-position.

1. Remove avionics bay access panel along the aft portion of the RH fuselage or the lower aft center access panel of baggage compartment.
2. Disconnect fixed antenna lead from front of unit.
3. Disconnect lead from remote switch and indicator unit.
4. Disconnect antenna from mounting tray.
5. Loosen attach straps and remove transmitter unit.
6. Attach antenna to antenna jack on front of unit.
7. Set main control switch to ON.
8. Hold antenna upright as much as possible.

Section 4 - Normal Procedures

No Change.

Section 5 - Performance

No Change.

Section 6 - Weight & Balance

Installation of the subject propeller adds the following optional (Sym = O) equipment at the weight and arm shown in the following table.

ATA / Item	Description	Sym	Qty	Part Number	Unit Wt	Arm
25-01	Artex ME406 ELT and Batteries	O	1	17190-100	3.4	229.5

Section 7 - Systems Description

This airplane is equipped with a self-contained Artex ME406 406 MHz ELT System. The transmitter unit is automatically activated upon sensing a change of velocity along its longitudinal axis exceeding 4 to 5 feet per second. Once activated, the transmitter transmits VHF band audio sweeps at 121.5 Mhz until battery power is gone. In addition, for the first 24 hours of operation, a 406 MHz signal is transmitted at 50-second intervals. This transmission lasts 440 ms and contains identification data received by Cospas-Sarsat satellites. The transmitted data is referenced in a database maintained by the national authority responsible for ELT registration to identify the beacon and owner. The ELT transmitter is installed immediately behind the aft cabin bulkhead, slightly to the right of the airplane centerline. The transmitter and antenna are accessible through the avionics bay access panel along the aft portion of the RH fuselage or the lower aft center access panel of baggage compartment. The main transmitter control switch is labeled "ON" - "ARM". The transmitter is in the armed position for normal operations. A red LED annunciator flashes when the ELT is transmitting. A battery pack consisting of two "D" cell lithium batteries mounts to a cover assembly within the transmitter to provide power to the transmitter. The expiration date of the batteries are indicated on the outside of the ELT battery case and recorded in the aircraft logs. A warning buzzer is mounted to the transmitter mounting tray. When the ELT is activated, the buzzer "beeps" periodically. This buzzer operates in tandem with the ELT panel indicator and serves as a redundant annunciation. Power to the buzzer is supplied by the ELT batteries. *Serials 22-0002 thru 22-2978, 22-2980 thru 22-2991, and 22-2993 thru 22-3001*; The ELT Remote Switch and Control Panel Indicator (RCPI) is located below the circuit breakers on the circuit breaker panel or *Serials 22-2979, 22-2992, and 22-3002 and subsequent, 22T-0001 and subsequent*, below the Alternate Induction Air Control knob near the pilot's right knee. The RCPI provides test and monitoring functions for the transmitter. The panel contains a switch labeled "ON" - "ARM", and a red LED annunciator. The red LED annunciator flashes when the ELT is transmitting. Power to the LED is supplied by either the clock bus on the MCU (*Serials 22-1863 thru 22-2083*) or by a 6V lithium battery in the RCPI (*Serials 22-2084 and subsequent, 22T-0001 and subsequent*).

Section 8 - Handling, Servicing & Maintenance

ELT and RCPI batteries must be inspected in accordance with the Airplane Maintenance Manual, 5-20 - Scheduled Maintenance Checks.

The ELT and RCPI batteries must be replaced upon reaching the date stamped on the batteries, after an inadvertent activation of unknown duration, or whenever the batteries have been in use for one cumulative hour.

Inspection / Test

After setting transmitter switch to ARM position, the ELT automatically enters a self-test mode. The self-test transmits a 406 MHz test coded pulse that monitors certain system functions before shutting off. The test pulse is ignored by any satellite that receives the signal, but the ELT uses this pulse to check output power and frequency. Other parameters of the ELT are checked and a set of error codes is generated if a problem is found. The error codes are indicated by a series of pulses on the transmitter LED, remote control panel indicator LED, and alert buzzer.

• Note •

FAA regulations require that transmitter tests only be done during the first 5 minutes of each hour and must not last for more than 3 audio sweeps (1.5 seconds). If you are at a location where there is an FAA control tower or other monitoring facility, notify the facility before beginning the tests. Never activate the ELT while airborne for any reason.

Operators may wish to use a low quality AM broadcast receiver to determine if energy is being transmitted from the antenna. When the antenna of the radio (tuning dial on any setting) is held about 6 inches from the activated ELT antenna, the ELT aural tone will be heard on the AM broadcast receiver. This is not a measured check, but it does provide confidence that the antenna is radiating sufficient power to aid search and rescue. The aircraft's VHF receiver, tuned to 121.5 MHz, may also be used. This receiver, however, is more sensitive and could pick up a weak signal even if the radiating ELT's antenna is disconnected. Thus it does not check the integrity of the ELT

system or provide the same level of confidence as does an AM radio.

1. Tune aircraft receiver to 121.5 MHz.
2. Turn the ELT aircraft panel switch "ON" for about 1 second, then back to the "ARM" position. The receiver should transmit about 3 audio sweeps.
3. At turn-off (back to 'ARM' state) the panel LED and buzzer should present 1 pulse. If more are displayed, determine the problem from the list below.
4. Codes displayed with the associated conditions are as follows:
 - a. 1-Flash: Indicates that the system is operational and that no error conditions were found.
 - b. 2-Flashes: Not used. If displayed, correct condition before further flight.
 - c. 3-Flashes: Open or short circuit condition on the antenna output or cable. If displayed, correct condition before further flight.
 - d. 4-Flashes: Low power detected. If displayed, correct condition before further flight.
 - e. 5-Flashes: Indicates that the ELT has not been programmed. Does not indicate erroneous or corrupted programmed data. If displayed, correct condition before further flight.
 - f. 6-Flashes: Indicates that G-switch loop is not installed. If displayed, correct condition before further flight.
 - g. 7-Flashes: Indicates that the ELT battery has too much accumulated operation time (> 1hr). If displayed, correct condition before further flight.

Section 10 - Safety Information

No Change.

Intentionally Left Blank

**Pilot's Operating Handbook and
FAA Approved Airplane Flight Manual
Supplement
for the**

TKS Anti-Ice System

- Approved for Flight Into Known Icing (FIKI)
- 8.0 gallon usable capacity.
- 4.0 gallon tank in each wing.

When the TKS Anti-Ice System is installed on the aircraft, this POH Supplement is applicable and must be inserted in the Supplements Section of the Pilot's Operating Handbook. This document must be carried in the airplane at all times. Information in this supplement adds to, supersedes, or deletes information in the basic Pilot's Operating Handbook

• Note •

This POH Supplement Change, dated Revision 04: 12-17-10, supersedes and replaces the Revision 03 Issue of this POH Supplement dated 01-06-10.

FAA Approved

Joseph C. Miss

Dec 17 2010
Date _____

for Charles Smalley, Manager
Chicago Aircraft Certification Office, ACE-115C
Federal Aviation Administration

Section 1 - General

This system, when compliant with the Kinds of Operation Equipment List and Minimum Dispatch Fluid Quantity, allows flight in icing conditions as defined by Title 14 of the Code of Federal Regulations (CFR) Part 25, Appendix C - Envelopes for Continuous Maximum and Intermittent Maximum Icing.

Section 2 - Limitations

In icing conditions the airplane must be operated as described in the operating procedures section of this manual. Where specific operational speeds and performance information have been established for such conditions, this information must be used.

At the first sign of Anti-Ice System malfunction, the aircraft must immediately exit icing conditions.

Environmental Conditions

Flight into freezing rain or freezing drizzle is prohibited.

Known icing conditions are defined by FAR Part 25, Appendix C. These conditions do not include, nor were tests conducted in all icing conditions that may be encountered such as freezing rain, freezing drizzle, mixed conditions or conditions defined as severe. Flight in these conditions must be avoided. Some icing conditions not defined in FAR Part 25 have the potential of producing hazardous ice accumulations, which exceed the capabilities of the airplane's Anti-Ice System, and/or create unacceptable airplane performance including loss of control.

Inadvertent operation in freezing rain, freezing drizzle, mixed conditions, or conditions defined as severe may be detected by:

- Visible rain at temperatures below 41°F (5°C) OAT.
- Droplets that splash or splatter on impact at temperatures below 41°F (5°C) OAT.
- Ice on or behind the wing or horizontal tail panels that cannot be removed with Anti-Ice System HIGH flow.
- Unusually extensive ice accreted on the airframe in areas not normally observed to collect ice.

- Accumulation of ice on the upper surface or lower surface of the wing aft of the protected area.
- Accumulation of ice on the propeller spinner farther back than normally observed.

If the airplane encounters conditions that are determined to contain freezing rain, freezing drizzle, or severe icing, immediately exit condition by changing altitude, turning back, or if clear air is known to be immediately ahead, continue on course. Once clear of these weather conditions, report encountered weather to air traffic control

• Note •

The National Weather Service's Automated Surface Observing Systems (ASOS) program does not report freezing drizzle. It is the pilot's responsibility to evaluate and understand weather along the intended route and identify any potential weather hazards thru evaluation of, but not limited to, Current Observations, Pilot Reports, Area Forecasts, AIRMETS, SIGMETS, and NOTAMS.

Airspeed Limitations

Minimum airspeed for flight into known icing conditions..... 95 KIAS*

*Includes all phases of flight, including approach, except as required for takeoff and landing.

Max airspeed Anti-Ice System operation..... 177 KIAS and 204 KTAS

Recommended holding airspeed..... 120 KIAS

Weight Limits

Maximum weight for flight into known icing conditions 3400 lb

Takeoff Limits

Takeoff is prohibited with any ice, snow, frost or slush adhering to the wing, stabilizers, control surfaces, propeller blades, or engine inlet.

Performance Limits

Refer to Section 5 - Performance for limitations that reflect effects on lift, drag, thrust and operating speeds related to operating in icing conditions.

Minimum Operating Temperature

Minimum Operating Temperature for Anti-Ice System..... -30°F (-34°C)

Kinds of Operation

This system allows flight into known icing as defined by Title 14 of the Code of Federal Regulations (CFR) Part 25, Appendix C - Envelopes for Continuous Maximum and Intermittent Maximum Icing.

This airplane is approved for flight into known icing conditions only if the following ATPI and FAA approved equipment is installed and fully functional.

System, Instrument, and/or Equipment	Kinds of Operation	
	IFR Day	IFR Nt.
Placards and Markings		
Airplane Flight Manual Supplement	1	1
Ice and Rain Protection		
Windshield Spray Nozzles	1	1
Wing LH and RH Inboard Panel	1	1
Wing LH and RH Outboard Panel	1	1
Horizontal Stabilizer LH and RH Panel	1	1
Vertical Stabilizer Panel	1	1
Elevator Tip LH and RH Panel	1	1
Propeller Slinger Ring	1	1
Deicing Fluid (Must meet British Specification DTD 406B.)	As Req'd	As Req'd
Lights		
Ice-Inspection Lights		1
System Control and Annunciation	1	1
Environmental System		
Cabin Heat and Defroster System	1	1
Flight Controls		
Heated Stall Warning System and Annunciation	1	1
Navigation and Pitot Static		
Pitot Heat	1	1

Minimum Dispatch Fluid Quantity

Dispatch into known icing conditions with less than 5 gallons (19 liters) of deicing fluid is prohibited. The pilot must ensure adequate fluid quantity before each flight. If dispatching without the minimum 5 gallons and icing conditions are encountered, exit icing conditions as soon as possible.

Duration Times for 5 Gallon Minimum Dispatch Fluid Quantity:

NORM.....	90 Minutes
HIGH.....	45 Minutes
MAX.....	22.5 Minutes

Deicing Fluid Limits

Usable Tank Capacity.....	8 gal (30L)
Tank Capacity.....	8.5 gal (32L)

Maximum Operating Time

Continuous operation of the aircraft in conditions that promote ice accretion is prohibited. Use of the windshield de-ice system will reduce the maximum available operating time of the system.

Normal Flow Duration.....	150 Minutes (3.2 gph)
High Flow Duration.....	75 Minutes (6.4 gph)
Maximum Flow Duration.....	37.5 Minutes (12.8 gph)

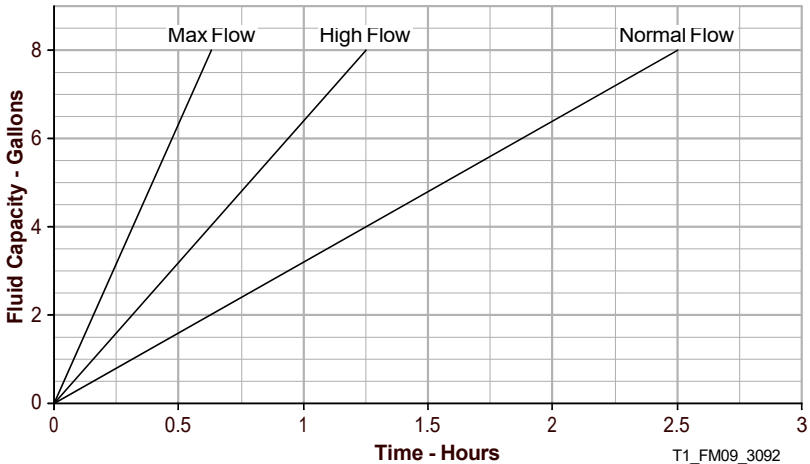

Systems and Equipment Limits

Lift Transducer Heat System

Limit ground operations of Lift Transducer Heat (PITOT HEAT) to 45 seconds.

Autopilot System

Autopilot operation is prohibited when operating in icing conditions which are outside of the CFR defined conditions as stated in the preceding Environmental Conditions paragraph.

Flap System

Unless required for Emergency operations (i.e. Forced Landing), Flaps are limited to a maximum deflection of 50% when the aircraft has encountered icing conditions and/or has accumulated ice on the airframe

When holding in icing conditions the flaps must be UP (0%).

Pilot Qualification and Training

• Note •

The Pilot Qualification and Training Limitation does not apply to airplanes registered in the European Union.

The pilot-in-command must successfully complete the ATPI Icing Awareness Course or a ATPI Design approved equivalent training course, within the preceding 24 months prior to Flight Into Forecast or Known Icing Conditions.

Contact ATPI Design at (218) 529-7292 for additional information.

Placards

Lower wing, above anti-ice fluid drain:

TKS FLUID DRAIN

Upper wing, above anti-ice fluid filler cap:

TKS ICE PROTECTION FLUID
USE ONLY AL-5 (DTD-406B) FLUID
4.0 US GALLONS (15.1 LITERS)
TOTAL USABLE CAPACITY



Bolster Switch Panel, left edge:

**THIS AIRCRAFT IS CERTIFIED FOR
THE FOLLOWING FLIGHT OPERATIONS
DAY - NIGHT - VFR - IFR
FLIGHT INTO KNOWN ICING WITH
REQUIRED EQUIPMENT**

**OPERATE PER AIRPLANE
FLIGHT MANUAL**

**MAXIMUM FLAP POSITION 50% IF
ICING CONDITIONS HAVE BEEN
ENCOUNTERED**

T1_FM09_2964

**Figure - 1
Required Placards**

Section 3 - Emergency Procedures

A failure of the Anti-Ice System is any condition, observed or suspected, in which the system fails to remove ice from protected surfaces including the propeller, in addition to any Anti-Ice System CAS failure annunciations. An unobserved failure may be indicated by a decrease in airspeed, anomalous handling characteristics, or airframe vibrations.

• Note •

Significant loss in cruise or climb performance may be an indication of propeller ice accretions that are not visible to the naked eye. Operation of the engine at 2700 RPM will help shed ice in severe icing conditions.

• Caution •

Continuous ice accumulations on protected areas are abnormal.

• **WARNING** •

With ice accumulations on the horizontal stabilizer leading edge, flaps should remain retracted for landing and the landing speed increased accordingly.

With asymmetrical ice accumulations on large portions of the wing or horizontal stabilizer, avoid flight at speeds less than 95 KIAS.

Anti-Ice System Failure / Excessive Ice Accumulation

1. ICE PROTECT A and B Circuit Breakers..... SET
2. Fluid Quantity..... SWITCH TO FULLEST TANK
3. WIND SHLD Push-Button..... PRESS
 - a. Repeat operation of windshield pump to verify metering pumps are primed properly as evidenced by deicing fluid exiting windshield nozzles.
4. ICE PROTECT Mode Switch VERIFY HIGH
5. PUMP BKUP SwitchON

If determined windshield pump is not priming:
6. Exit Icing Conditions Immediately.
7. Airspeed.....95 KIAS OR GREATER

Maintain a minimum airspeed of 95 KIAS or higher to stay above pre-stall buffet. If unable to maintain this airspeed, allow altitude to decrease in order to maintain 95 KIAS.
8. Minimum Approach Speed w/ Residual Ice (Flaps 50%)...88 KIAS

In severe icing conditions, it may not be possible to maintain altitude or proper glide path on approach; in this case, it is imperative that a safe airspeed be maintained, the stall warning system may not function and there may be little or no pre-stall buffet with heavy ice loads on the wing.
9. FLAPS MINIMUM REQUIRED

When landing is assured, select the minimum flap setting required, not to exceed 50%, and maintain extra airspeed consistent with available field length. Do not retract the flaps once they have been extended unless required for go-around.

Maximum Glide with Ice Accumulation

Conditions

Example:

Power	OFF	Altitude	10,000 ft. AGL
Propeller	Windmilling	Airspeed	88 KIAS
Flaps	0% (UP)	Glide Distance	12.7 NM
Wind	Zero		

Best Glide Speed

88 KIAS at 3400 lb

Maximum Glide Ratio ~ 7.7: 1

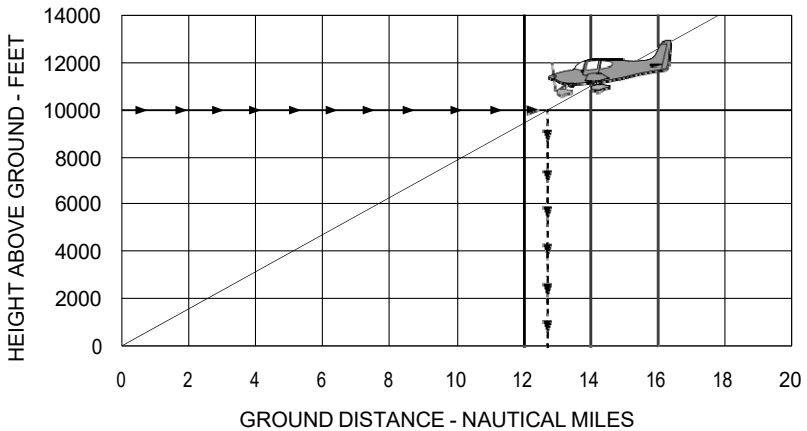

Section 3A - Abnormal Procedures

Windshield De-Ice System Malfunction

1. ICE PROTECT A Circuit Breaker CYCLE
2. Fluid Quantity SWITCH TO FULLEST TANK
3. WIND SHLD Push-Button PRESS AS REQUIRED

If the forward field of view is overly restricted during landing approach and taxiing:

- a. Cabin HeatHOT
- b. Windshield DefrostON
- c. Execute a forward slip as required for visibility.
- d. Avoid taxiing without adequate forward visibility.

Heated Lift Transducer Malfunction

Airframe buffet before the stall is a good indication of an impending stall.

The stall warning horn typically activates prematurely if there is ice accumulated on the lift transducer vane.

Some ice accumulation on the inboard/outboard edges of the lift transducer faceplate is considered normal.

If ice forms on lift transducer vane:

1. STALL VANE HEAT Circuit Breaker CYCLE
2. PITOT HEAT Switch CYCLE OFF, ON

If ice remains on lift transducer vane:

1. Stall Warning System EXPECT NO RELIABLE INDICATION
This includes:
 - *Impending stall warning.*
 - *Stall speed indication.*
2. Airspeed MONITOR, DO NOT STALL
3. Fly published V_{REF} speeds Minimum 88 KIAS with 50% Flap

Static System Malfunction

If erroneous readings on the pilot's flight instruments are suspected the static button(s) on side of fuselage may be obstructed. Refer to Section 3A - Abnormal Procedures, Static Source Blocked in the basic handbook.

Anti-Ice System CAS Annunciations

• Note •

During Anti-Ice System activation, system mode changes, operation at temperatures above freezing or with warm deicing fluid, occasional ANTI ICE annunciations are normal.

Low Fluid Quantity Caution and Warning

ANTI ICE QTY

PFD Alerts Window: "Fluid quantity is low (TKS)"

ANTI ICE QTY Warning: Fluid quantity is less than 0.5 gallon. (1.9 L)

ANTI ICE QTY Caution: Fluid quantity is less than 1.0 gallon. (3.8 L)

• Note •

Depending on the selected flow rate, ANTI ICE QTY annunciation may occur at lower fluid quantities

1. Icing Conditions AVOID / EXIT

Low Flow Rate Warning

ANTI ICE FLO

PFD Alerts Window: "Flow rate is low (TKS)"

1. ICE PROTECT A and B Circuit Breakers..... SET
2. Fluid Quantity SWITCH TO FULLEST TANK
3. WIND SHLD Push-ButtonPRESS
 - a. Repeat operation of windshield pump to verify metering pumps are primed properly as evidenced by deicing fluid exiting windshield nozzles.

4. ICE PROTECT Mode Switch HIGH

If warning annunciation extinguishes:

a. Anti-Ice System MONITOR

If warning annunciation does not extinguishes or intermittent:

a. PUMP BKUP Switch.....ON

b. Icing Conditions..... AVOID / EXIT

Lift Transducer Overheat Warning

AOA OVERHEAT

PFD Alerts Window: "AOA probe is overheated"

• Note •

Operation of Pitot Heat on hot days may annunciate the AOA OVERHEAT Warning when flying at slow speeds. When air temperatures are greater than 41°F (5°C), operation of Pitot Heat is at discretion of the pilot. If overheat warning is annunciated, Pitot Heat should remain OFF.

1. PITOT HEAT Switch..... OFF

2. Icing Conditions AVOID/EXIT

Tank Control Failure Warning

ANTI ICE CTL

PFD Alerts Window: "Tank valves cannot be controlled (closed) (TKS)"

Tank selection is inoperative and both left and right are open, typical with GIA failure.

1. Icing Conditions AVOID / EXIT

Unreliable Fluid Quantity Warning

ANTI ICE QTY

PFD Alerts Window: "Left and right fluid quantities unknown (TKS)"

Both fluid quantities are unknown and both tanks are closed.

- 1. ICE PROTECT System Switch.....OFF
- 2. Icing Conditions AVOID / EXIT

Low Pressure Caution.

ANTI ICE PSI

PFD Alerts Window: "Tail pressure is low (TKS)"

• Caution •

A persistent Low Pressure Caution indicates a condition in the tail section of Anti-Ice System and warrants increased caution because the tail section's smaller leading edge radius will typically collect ice more quickly and ice accretion is more difficult to monitor.

- 1. ICE PROTECT A and B Circuit Breakers..... SET
- 2. Fluid Quantity SWITCH TO FULLEST TANK
- 3. WIND SHLD Push-ButtonPRESS
 - a. Repeat operation of windshield pump to verify metering pumps are primed properly as evidenced by deicing fluid exiting windshield nozzles.
- 4. ICE PROTECT Mode Switch..... HIGH

If caution annunciation extinguishes:

- a. Anti-Ice System MONITOR

If caution annunciation does not extinguishes or intermittent:

- a. PUMP BKUP Switch..... ON
- b. Icing Conditions AVOID / EXIT

High Pressure Caution

ANTI ICE PSI

PFD Alerts Window: "Pressure is high (TKS)"

Typically indicates clogged filter.

- 1. Evidence of Anti-Ice Flow MONITOR / VERIFY
- 2. Icing Conditions AVOID / EXIT

Airspeed Caution

ANTI ICE SPD

PFD Alerts Window: "Airspeed is too low/high for ice protection (TKS)"

ANTI ICE SPD Low: Airspeed is less than 95 KIAS

ANTI ICE SPD High: Airspeed is greater than 177 KIAS or 204 KTAS

- 1. Airspeed..... MAINTAIN 95-177 KIAS
or less than 204 KTAS

Lift Transducer Heater Failure Caution

ANTI ICE HTR

PFD Alerts Window: "Stall warning/AoA heater has failed"

- 1. STALL VANE HEAT Circuit Breaker CYCLE
- 2. PITOT HEAT Circuit Breaker..... CYCLE
- 3. Icing Conditions AVOID / EXIT
- 4. Fly aircraft normally using airframe buffet as the stall warning. Ice accumulations on the lift transducer vane may result in unreliable stall warning system operation.

Fluid Quantity Imbalance Caution

ANTI ICE QTY

PFD Alerts Window: "Fluid quantity imbalance has been detected"

Imbalance between left and right sensed fluid quantity is greater than 1.0 gallon.

1. Revert to AUTO control of the fluid source to control the fluid quantity.

If ANTI ICE FLO or ANTI ICE PSI annunciates:

- a. Revert to manual control of the fluid source to control the fluid level quantity

(1) Fluid QuantitySWITCH TO FULLEST TANK

- b. WIND SHLD Push-Button.....PRESS

(1) Repeat operation of windshield pump to verify metering pumps are primed properly as evidenced by deicing fluid exiting windshield nozzles.

If Caution Annunciation extinguishes:

- a. Anti-Ice System MONITOR

If Caution Annunciation does not extinguish or intermittent:

- a. Fluid Quantity SWITCH TO OPPOSITE TANK

- b. WIND SHLD Push-Button.....PRESS

(1) Repeat operation of windshield pump to verify metering pumps are primed properly as evidenced by deicing fluid exiting windshield nozzles.

- c. Icing ConditionsAVOID / EXIT

Left/Right Fluid Quantity Caution

ANTI ICE LVL

PFD Alerts Window: "Right/Left tank fluid quantity is unreliable (TKS)"

L / R fluid quantities on Anti Ice - TKS block of ENGINE page is "greyed out" and/or fluid quantity is marked with a "Red X". The deicing fluid sensing system has detected conflicting system information regarding the fluid quantity in the tanks.

1. Revert to manual control of the fluid source to control the fluid level quantity.

If ANTI ICE FLO or ANTI ICE PSI annunciates:

- a. Fluid Quantity SWITCH TO OPPOSITE TANK
- b. WIND SHLD Push-ButtonPRESS
 - (1) Repeat operation of windshield pump to verify metering pumps are primed properly as evidenced by deicing fluid exiting windshield nozzles.

Dynamic Stall Speed Band Unavailable Advisory

AOA FAIL

PFD Alerts Window: "Dynamic stall speed band is unavailable."

Angle of Attack signal has failed. This signal is used to calculate and display a dynamic stall speed awareness band (red band) on airspeed tape. With a failed AOA signal, the low speed red band extends to a fixed value of 61 knots.

Section 4 - Normal Procedures

• WARNING •

Holding in icing conditions for longer than 45 minutes may reduce margins and could result in inadequate handling and control characteristics.

Flight into known icing conditions is prohibited if porous panels do not fully "wet-out" prior to entering icing conditions, or if ANTI ICE CAS messages persist.

• Caution •

Prolonged operation of the system in clear air, above 15,000 feet MSL and temperatures less than -4 F (-20 C) can result in "flash" evaporation of water and alcohol from the anti-ice fluid. This evaporation results in a glycol rich fluid that could become "gel" like on the wing surface until aircraft enters precipitation or warmer temperatures

Limit ground operations of Lift Transducer Heat (PITOT HEAT) to 45 seconds. Operation of Lift Transducer Heat in excess of 45 seconds while on the ground may cause excessive temperature on the lift transducer faceplate and surrounding wing skin.

• Note •

This system is most effective when operated as an anti-ice system to prevent ice accretions on protected surfaces. For optimal performance, the system should be primed on the ground to verify all protected surfaces wet-out fully. The system should then be activated prior to entering icing conditions to confirm the protected surfaces wet-out fully before ice accretion begins.

The Anti-Ice System is approved for operation with ice protection fluid that has a very temperature-dependent viscosity characteristic. As the temperature of the fluid rises above freezing (32F / 0C), the fluid becomes much less viscous (thins) and pass through the porous membrane of the panels with less resistance (pressure drop). This decrease in pressure drop reduces the pressure in the panel reservoir

which may not be adequate to wet-out the entire panel if the Pre-Flight Inspection is performed at warmer temperatures.

Increasing the system flow rate (MAX vs. HIGH or HIGH w/ PUMP BKUP vs. HIGH) will increase the arterial pressure of the system which promotes the complete wet-out of the porous panels.

Pre-Flight Inspection

1. Cabin
 - a. Circuit Breakers SET
 - b. Battery 1 Master Switch ON
 - c. Flaps 100%
 - d. Avionics Master Switch ON
 - e. Cabin Speaker ON
 - f. Cabin Doors CLOSE
 - g. WIND SHLD Push-Button PRESS
 - (1) Verify evidence of deicing fluid from spray nozzles.
 - h. PUMP BKUP Switch ON
 - (1) Metering Pump Duty Cycle Verify Continuously ON
 - (2) Deicing Fluid and Endurance Indications CHECK
 - i. PUMP BKUP Switch OFF
 - j. ICE PROTECT System Switch ON
 - k. ICE PROTECT Mode Switch NORM
 - (1) Metering Pump Duty Cycle Verify 30s ON, 90s OFF
 - (2) Deicing Fluid and Endurance Indications CHECK
 - l. ICE PROTECT Mode Switch HIGH
 - (1) Metering Pump Duty Cycle Verify Continuously ON
 - (2) Deicing Fluid and Endurance Indications CHECK
 - m. ICE Inspection Lights Switch ON
 - (1) Verify LH and RH Operation.

Continued on following page.

- n. PITOT HEAT Switch..... ON 45 seconds, then OFF
- 2. Empennage
 - a. Stabilizers Porous PanelsCONDITION / SECURITY
 - (1) Verify Evidence of Deicing Fluid Along Length of Panels and Elevator Horns.
- 3. Right Wing Forward and Main Gear
 - a. Fluid Tank VERIFY DESIRED QUANTITY
 - (1) Filler Cap..... CONDITION AND SECURITY.
 - (2) Fluid Vent (underside wing)..... UNOBSTRUCTED
 - b. Porous Panels..... CONDITION AND SECURITY
 - (1) Verify Evidence of Deicing Fluid Along Length of Panels.

• WARNING •

Lift Transducer Faceplate and Vane may be HOT.

- c. Lift Transducer Faceplate PERCEPTIBLY HOT
- d. Lift Transducer Vane VERY HOT
 - (1) Verify Stall Warning audio alert after lifting stall vane with wooden tooth pick or tongue depressor.
- 4. Nose, Right Side
 - a. Ice-Inspection LightCONDITION / SECURITY
- 5. Nose Gear, Propeller, Spinner
 - a. Slinger Ring EVIDENCE OF DEICING FLUID
- 6. Nose, Left Side
 - a. Ice-Inspection LightCONDITION / SECURITY
 - b. Windshield Spray NozzlesCONDITION / SECURITY
- 7. Left Wing Forward and Main Gear
 - a. Fluid Tank VERIFY DESIRED QUANTITY
 - (1) Filler Cap..... CONDITION AND SECURITY.
 - (2) Fluid Vent (underside wing)..... UNOBSTRUCTED
 - b. Porous Panels..... CONDITION / SECURITY
 - (1) Verify Evidence of Deicing Fluid Along Length of Panels.

8. Left Wing Tip

• WARNING •

Pitot Probe may be HOT.

- a. Pitot Probe (underside) UNOBSTRUCTED
 - b. Pitot Probe..... VERY HOT
9. Cabin
- a. Fluid Quantity VERIFY 5 GALLON MINIMUM
 - b. ICE PROTECT System Switch OFF
 - c. Flaps..... 0%
 - d. Battery 1 Master Switch OFF
 - e. Avionics Master Switch..... OFF
 - f. Cabin Speaker..... OFF

Ice Formation Determination

Typically, a leading edge with a small radius will collect ice more quickly than a leading edges with a large radius. To help monitor possible ice accumulation, a thin metal tab is attached to the outboard end of the RH and LH stall strips. In some icing conditions this tab may be the first place that airframe ice accretion is noticeable. Additionally, refer to other areas of the aircraft, such as the horizontal tail and lower windscreen, to aid in determining if ice is accreting to the aircraft.

Before Takeoff

If icing conditions are anticipated immediately after take-off:

1. ICE PROTECT System Switch..... ON
2. ICE PROTECT Mode Switch..... NORM / HIGH
3. PITOT HEAT Switch ON
4. Cabin Heat HOT
5. Windshield Defrost..... ON
6. Ice-Inspection Lights AS REQUIRED
7. Verify airframe is free of contamination immediately before takeoff.
8. Flaps RETRACT as soon as practical

In Flight

If Inadvertent Icing Encounter OR Icing Conditions Exist:

1. PITOT HEAT SwitchVerify ON
2. ICE PROTECT System Switch..... ON
3. ICE PROTECT Mode Switch..... NORM
4. WIND SHLD Push-Button PRESS AS REQUIRED
5. Monitor ice accumulation.

If ice accretions persist on protected surfaces following each cycle:

- a. ICE PROTECT Mode..... HIGH

If ice continues accumulating on protected surfaces:

- b. ICE PROTECT Mode Push-Button..... MAX

If ice accretions do not shed from protected surfaces:

- c. PUMP BKUP Switch..... ON
- d. Perform Anti-Ice System Failure checklist.
- e. WIND SHLD Push-Button.....PRESS AS REQUIRED
- f. AirspeedMAINTAIN 95-177 KIAS
or less than 204 KTAS

While in Icing Conditions:

- 1. FLAPS UP
- 2. Ice-Inspection Lights AS REQUIRED
- 3. Cabin HeatHOT
- 4. Windshield Defrost.....ON
- 5. Fluid Quantity and Endurance MONITOR
 - a. Ensure adequate quantity to complete flight.

After Leaving Icing Conditions:

- 1. Anti-Ice System..... OFF
- 2. Airspeed.....as flight CONDITIONS DICTATE
- 3. Ice-Inspection Lights AS REQUIRED
- 4. Cabin Heat AS REQUIRED
- 5. Windshield Defrost..... AS REQUIRED
- 6. WIND SHLD Push-Button PRESS AS REQUIRED

Cruise

During icing encounters in cruise, increase engine power to maintain cruise speed as ice accumulates on the unprotected areas and causes the aircraft to slow down.

The autopilot may be used in icing conditions. However, every 30 minutes the autopilot should be disconnected to detect any out-of-trim conditions caused by ice buildup. If significant out-of-trim or other anomalous conditions are detected, the autopilot should remain off for the remainder of the icing encounter.

When disconnecting the autopilot with ice accretions on the airplane, the pilot should be alert for out-of-trim forces.

Approach and Landing

If Icing Conditions Exist:

1. ICE PROTECT System Switch..... ON
2. ICE PROTECT Mode Switch..... HIGH
3. Monitor ice accumulation.

If ice continues accumulating on protected surfaces:

- a. ICE PROTECT Mode Push-Button..... MAX

If ice accretions do not shed from protected surfaces:

- b. PUMP BKUP Switch..... ON
 - c. Perform Anti-Ice System Failure checklist.
4. WIND SHLD Push-Button..... PRESS AS REQUIRED

• Caution •

To prevent an obstructed view due to residual deicing fluid on windshield, do not operate windshield de-ice system within 30 seconds of landing.

5. Ice-Inspection Lights..... AS REQUIRED
6. Flaps.....50%
7. Airspeed..... Minimum of 95 KIAS
8. Airspeed on Short Final.....88 KIAS

After Landing and Shutdown

1. PITOT HEAT Switch OFF
2. ICE PROTECT System Switch OFF
3. PUMP BKUP Switch OFF
4. Ice-Inspection Lights OFF

• Note •

When the Anti-Ice System has been used, avoid touching the airframe structure or windshield as they will be partially covered with deicing fluid. Clean the deicing fluid from the windshield and the porous panels as described in Section 8, Handling, Service, and Maintenance.

Section 5 - Performance

Airplane performance and stall speeds without ice accumulation are essentially unchanged with the installation of the Ice Protection System. *Serials T1T-0001 and subsequent:* Performance of the airplane with the Teledyne Continental TSIO-550-K turbocharged engine installed is equal to or better than the performance described in the following section.

Significant climb and cruise performance degradation, range reduction, as well as buffet and stall speed increase can be expected if ice accumulates on the airframe. Residual ice on the protected areas and ice accumulation on the unprotected areas of the airplane can cause noticeable performance losses and stall speed increases even with the Anti-Ice System operating.

Stall Speeds with Ice Accumulation

Conditions:

- Weight 3400 LB
- CG Noted
- Power Idle
- Bank Angle Noted

• Note •

Altitude loss during wings level stall may be 600 feet or more.

KIAS values may not be accurate at stall.

Weight LB	Bank Angle Deg	STALL SPEEDS					
		Flaps 0% Full Up		Flaps 50%		Flaps 100% Full Down	
		KIAS	KCAS	KIAS	KCAS	KIAS	KCAS
3400 Most FWD CG	0	75	73	70	68	66	64
	15	76	74	72	69	65	65
	30	80	79	75	73	69	69
	45	88	87	81	81	76	76
	60	104	104	97	97	90	90
3400 Most AFT CG	0	73	71	69	67	65	63
	15	74	72	71	68	64	64
	30	77	76	74	72	68	68
	45	85	84	80	80	75	75
	60	100	100	95	95	89	89

Enroute Climb Gradient with Ice Accumulation

Conditions:

- PowerFull Throttle
- MixtureSet Per Placard
- Flaps0% (UP)
- Airspeed.....Best Rate of Climb

• Note •

Climb Gradients shown are the gain in altitude for the horizontal distance traversed expressed as Feet per Nautical Mile.

Fuel flow must be set to top of green arc for all takeoffs and climbs.

Cruise climbs or short duration climbs are permissible at best power as long as altitudes and temperatures remain within those specified in the table.

For operation in air colder than this table provides, use coldest data shown.

Negative climb data shown in heavier table borders.

Weight	Press Altitude	Climb Speed	CLIMB GRADIENT - Feet / Nautical Mile				ISA
			Temperature ~°C				
LB	FT	KIAS	-20	-10	0	5	ISA
3400	SL	101	517	498	480	470	
	2000	100	423	405	387	378	
	4000	98	332	315	298	289	
	6000	97	245	229	213	204	
	8000	96	162	146	131	123	132
	10000	95	82	67	52	45	60
	12000	95	6	-9	-22	-29	-10
	14000	95	-67	-79	-92	-98	-75
	16000	95	-137	-145	-157	-163	-137
2900	SL	101	663	641	619	608	
	2000	100	553	532	510	500	
	4000	98	447	427	407	397	
	6000	97	346	327	308	299	
	8000	96	250	232	213	204	215
	10000	95	158	140	123	114	131
	12000	95	68	52	37	28	50
	14000	95	-15	-29	-45	-52	-25
	16000	95	-92	-107	-120	-127	-97

Enroute Rate of Climb with Ice Accumulation

Conditions:

- Power..... Full Throttle
- Mixture..... As Required
- Flaps.....0% (UP)
- Airspeed Best Rate of Climb

• Note •

Rate-of-Climb values shown are change in altitude in feet per unit time expressed in Feet per Minute.

Fuel flow must be set to top of green arc for all takeoffs and climbs.

Cruise climbs or short duration climbs are permissible at best power as long as altitudes and temperatures remain within those specified in the table.

For operation in air colder than this table provides, use coldest data shown.

Negative climb data shown in heavier table borders.

Weight LB	Press Altitude FT	Climb Speed KIAS	RATE OF CLIMB ~ Feet per Minute				ISA
			Temperature ~°C				
			-20	-10	0	5	
3400	SL	101	817	803	787	779	
	2000	100	686	670	652	643	
	4000	98	553	535	516	506	
	6000	97	420	399	378	367	
	8000	96	285	262	239	227	241
	10000	95	148	124	99	86	111
	12000	95	10	-16	-43	-57	-19
	14000	95	-129	-157	-186	-201	-150
	16000	95	-270	-300	-331	-347	-280
2900	SL	101	1045	1030	1014	1005	
	2000	100	895	878	859	849	
	4000	98	744	725	704	693	
	6000	97	593	571	548	536	
	8000	96	439	415	390	377	392
	10000	95	285	258	231	217	244
	12000	95	129	100	71	56	97
	14000	95	-28	-59	-91	-107	-51
	16000	95	-187	-220	-254	-271	-198

Cruise Performance with Ice Accumulation

Conditions:

- Cruise Weight..... 2900 LB
- Winds..... Zero

• Note •

Aircraft with optional Air Conditioning System - Cruise performance is reduced by 2 knots. For maximum performance, the air-conditioner should be off.

2000 Feet Pressure Altitude										
RPM	MAP	ISA -30°C (-19°C)			ISA (11°C)			ISA + 30°C (41°C)		
		PWR	KTAS	GPH	PWR	KTAS	GPH	PWR	KTAS	GPH
2700	27.4	103%	160	24.6						
2600	27.4	99%	157	23.5						
2500	27.4	93%	153	22.1						
2500	26.4	89%	150	21.1						
2500	25.4	84%	146	20.0						
2500	24.4	80%	142	19.0						
2500	23.4	76%	137	18.0						

4000 Feet Pressure Altitude										
RPM	MAP	ISA -30°C (-23°C)			ISA (7°C)			ISA + 30°C (37°C)		
		PWR	KTAS	GPH	PWR	KTAS	GPH	PWR	KTAS	GPH
2700	25.4	96%	158	22.9						
2600	25.4	92%	155	21.9						
2500	25.4	87%	150	20.6						
2500	24.4	82%	146	19.5						
2500	23.4	78%	141	18.5						
2500	22.4	73%	136	17.4						
2500	21.4	69%	130	16.4						

Cruise Performance (Continued)

6000 Feet Pressure Altitude										
RPM	MAP	ISA -30°C (-27°C)			ISA (3°C)			ISA + 30°C (33°C)		
		PWR	KTAS	GPH	PWR	KTAS	GPH	PWR	KTAS	GPH
2700	23.5	89%	155	21.2	85%	155	20.1			
2600	23.5	85%	151	20.3	81%	151	19.2			
2500	23.5	80%	146	19.1	76%	146	18.1			
2500	22.5	76%	140	18.1	72%	140	17.1			
2500	21.5	72%	134	17.0	68%	134	16.1			
2500	20.5	67%	128	15.9	64%	128	15.1			
2500	19.5	63%	120	14.9	59%	120	14.1			

8000 Feet Pressure Altitude										
RPM	MAP	ISA -30°C (-31°C)			ISA (-1°C)			ISA + 30°C (29°C)		
		PWR	KTAS	GPH	PWR	KTAS	GPH	PWR	KTAS	GPH
2700	21.7	83%	150	19.7	78%	150	18.6			
2600	21.7	79%	146	18.8	75%	146	17.8			
2500	21.7	75%	140	17.7	71%	140	16.8			
2500	20.7	70%	133	16.7	66%	133	15.8			
2500	19.7	66%	126	15.6	62%	126	14.8			
2500	18.7	61%	117	14.5	58%	117	13.8			
2500	17.7	57%	108	13.5	54%	108	12.8			

10,000 Feet Pressure Altitude										
RPM	MAP	ISA -30°C (-35°C)			ISA (-5°C)			ISA + 30°C (25°C)		
		PWR	KTAS	GPH	PWR	KTAS	GPH	PWR	KTAS	GPH
2700	20.0	77%	144	18.2	73%	144	17.3			
2600	20.0	71%	136	17.0	68%	136	16.1			
2500	20.0	67%	129	16.0	64%	129	15.1			
2500	19.0	63%	120	14.9	59%	120	14.1			
2500	18.0	58%	111	13.8	55%	111	13.1			
2500	17.0	54%	100	12.8	51%	100	12.1			

Range / Endurance Profile with Ice Accumulation

Conditions:

- Weight..... 3400 LB
- Temperature..... Standard Day
- Winds..... Zero
- Mixture..... Best Economy
- Total Fuel..... 92 Gallons

• Note •

Range is decreased by a approximately 10% with ice accretion on the aircraft.
 Range is reduced by a maximum of 2% as a result of the Anti-Ice System installation.
 Residual ice on unprotected airplane surfaces can cause a loss in rate of climb of approximately 50%.
 Normally aspirated service ceiling is 10,000 feet density altitude with ice accretion.
 Fuel Remaining For Cruise is equal to 92.0 gallons usable, less climb fuel, less 9.8 gallons for 45 minutes IFR reserve fuel at 47% power (ISA @ 10,000 ft PA), less descent fuel, less fuel used prior to takeoff.
 Range and endurance shown includes descent to final destination at approximately 178 KIAS and 500 fpm.
 Aircraft with optional air-conditioning system - Range is decreased by 1%. For maximum range the air-conditioner should be off.

75% POWER					Mixture: Best Power		
Press Alt	Climb Fuel	Fuel Remaining For Cruise	Airspeed	Fuel Flow	Endurance	Range	Specific Range
FT	Gal	Gal	KTAS	GPH	Hours	NM	Nm/Gal
SL	0.0	81.8	139	17.8	4.6	639	7.8
2000	0.7	81.1	141	17.8	4.6	645	7.9
4000	1.3	80.4	143	17.8	4.5	650	8.1
6000	2.0	79.7	144	17.8	4.5	655	8.2
8000	2.7	79.0	146	17.8	4.4	660	8.3

Range / Endurance Profile (Continued)

65% POWER								Mixture: Best Power
Press Alt	Climb Fuel	Fuel Remaining For Cruise	Airspeed	Fuel Flow	Endurance	Range	Specific Range	
FT	Gal	Gal	KTAS	GPH	Hours	NM	Nm/Gal	
SL	0	81.8	127	15.4	5.3	674	8.2	
2000	0.7	81.1	128	15.4	5.3	677	8.3	
4000	1.3	80.4	129	15.4	5.2	679	8.4	
6000	2.0	79.7	130	15.4	5.2	681	8.5	
8000	2.7	79.0	131	15.4	5.1	681	8.6	
10000	3.5	78.2	131	15.4	5.1	681	8.7	
12000	4.4	77.4	132	15.4	5.0	681	8.8	

55% POWER								Mixture: Best Power
Press Alt	Climb Fuel	Fuel Remaining For Cruise	Airspeed	Fuel Flow	Endurance	Range	Specific Range	
FT	Gal	Gal	KTAS	GPH	Hours	NM	Nm/Gal	
SL	0	81.8	111	13.1	6.3	696	8.5	
2000	0.7	81.1	111	13.1	6.2	693	8.6	
4000	1.3	80.4	111	13.1	6.2	691	8.6	
6000	2.0	79.7	111	13.1	6.1	687	8.6	
8000	2.7	79.0	111	13.1	6.0	682	8.6	
10000	3.5	78.3	110	13.1	6.0	677	8.7	
12000	4.4	77.4	110	13.1	5.9	670	8.7	
14000	5.3	76.5	109	13.1	5.8	663	8.7	

55% POWER								Mixture: Best Economy
Press Alt	Climb Fuel	Fuel Remaining For Cruise	Airspeed	Fuel Flow	Endurance	Range	Specific Range	
FT	Gal	Gal	KTAS	GPH	Hours	NM	Nm/Gal	
SL	0	81.8	111	11.3	7.2	803	9.8	
2000	0.7	81.1	111	11.3	7.2	800	9.9	
4000	1.3	80.4	111	11.3	7.1	796	9.9	
6000	2.0	79.7	111	11.3	7.0	791	9.9	
8000	2.7	79.0	111	11.3	7.0	786	9.9	
10000	3.5	78.2	110	11.3	6.9	779	10.0	
12000	4.4	77.4	110	11.3	6.8	770	10.0	
14000	5.3	76.5	109	11.3	6.7	761	10.0	

Balked Landing Climb Gradient with Ice Accumulation

Conditions:

- Power Full Throttle
- Mixture Set per Placard
- Flaps 50% (DN)
- Climb Airspeed V_{REF}

• Note •

Balked Landing Climb Gradients shown are the gain in altitude for the horizontal distance traversed expressed as Feet per Nautical Mile.

For operation in air colder than this table provides, use coldest data shown.

This chart is required data for certification. However, significantly better performance can be achieved by climbing at Best Rate of Climb speeds shown with flaps down or following the Go-Around / Balked Landing procedure in Section 4.

Weight	Press Alt	Climb Speed, V _{REF}	CLIMB GRADIENT ~ Feet/Nautical Mile				
			Temperature ~°C				
			-20	-10	0	5	ISA
LB	FT	KIAS					
3400	SL	88	536	584	574	569	
	2000	88	449	441	433	428	
	4000	88	366	359	351	346	
	6000	88	288	281	273	268	
	8000	88	214	207	199	195	200
	10000	88	145	138	130	126	134
2900	SL	88	682	658	634	622	
	2000	88	551	529	506	495	
	4000	88	428	407	386	375	
	6000	88	313	293	273	263	
	8000	88	205	186	167	158	169
	10000	88	103	86	68	60	77

Balked Landing Rate of Climb with Ice Accumulation

Conditions:

- Power..... Full Throttle
- Mixture..... Set per Placard
- Flaps..... 50%
- Climb AirspeedV_{REF}

• Note •

Balked Landing Rate of Climb values shown are the full flaps change in altitude for unit time expended expressed in Feet per Minute.

For operation in air colder than this table provides, use coldest data shown.

This chart is required data for certification. However it is recommended that the best rate of climb speed with flaps down be used, or that the balked landing procedures of Section 4 of this POH be used for significantly better climb performance on a go-around.

Weight LB	Press Alt FT	Climb Speed, V _{REF} KIAS	RATE OF CLIMB - Feet per Minute					ISA
			Temperature ~°C					
			-20	-10	0	5		
3400	SL	88	740	745	747	747		
	2000	88	644	646	645	645		
	4000	88	546	545	543	541		
	6000	88	446	443	438	435		
	8000	88	345	340	333	329	333	
	10000	88	242	235	226	220	230	
2900	SL	88	941	926	909	900		
	2000	88	790	773	754	744		
	4000	88	638	618	597	586		
	6000	88	484	462	439	427		
	8000	88	329	305	279	266	282	
	10000	88	173	146	119	104	132	

Landing Distance with Ice Accumulation

Conditions:

- Winds Zero
- Runway Dry, Level, Paved

• Note •

The following factors are to be applied to the computed landing distance for the noted condition:

- Normal landings will be completed with the flaps set to 50%.
- Sloped Runway - Increase table distances by 27% of the ground roll distance for each 1% of downslope. Decrease table distances by 9% of the ground roll distance for each 1% of upslope.

• Note •

The above corrections for runway slope are required to be included herein for certification. They should be used with caution since published runway slope data is usually the net slope from one end of the runway to the other. Many runways will have portions of their length at greater or lesser slopes than the published slope, lengthening (or shortening) landing ground run values estimated from the published slope as described above.

- For operation in outside air temperatures colder than this table provides, use coldest data shown.
- For operation in outside air temperatures warmer than this table provides, use extreme caution.

Landing Distance - Flaps 50%

WEIGHT: 3400 LB
Speed over 50 Ft Obstacle: 88 KIAS
Flaps: 50%
Power: Smooth power reduction from obstacle to idle at touchdown.
Runway: Dry, Paved, Level

Headwind: Subtract 10% for each 13 knots headwind.
Tailwind: Add 10% for each 2 knots tailwind up to 10 knots.
Runway Slope: Reference Notes
Dry Grass: Add 20% to Ground Roll
Wet Grass: Add 60% to Ground Roll

PRESS ALT FT	DISTANCE FT	TEMPERATURE ~°C				ISA
		-20	-10	0	5	
SL	Grnd Roll	1346	1399	1452	1479	
	Total	2788	2861	2934	2972	
1000	Grnd Roll	1396	1451	1506	1533	
	Total	2856	2932	3010	3049	
2000	Grnd Roll	1448	1505	1562	1590	
	Total	2928	3008	3090	3131	
3000	Grnd Roll	1502	1561	1620	1650	
	Total	3004	3089	3174	3217	
4000	Grnd Roll	1558	1620	1682	1712	
	Total	3085	3174	3263	3309	
5000	Grnd Roll	1618	1682	1745	1777	
	Total	3170	3263	3358	3406	
6000	Grnd Roll	1680	1746	1812	1845	
	Total	3261	3359	3458	3508	
7000	Grnd Roll	1744	1813	1882		
	Total	3356	3459	3564		
8000	Grnd Roll	1812	1884	1955		
	Total	3458	3566	3675		
9000	Grnd Roll	1883	1957	2032		
	Total	3565	3679	3794		
10000	Grnd Roll	1957	2034			
	Total	3678	3798			

Section 6 - Weight & Balance

Refer to Section 6 - Weight and Balance of the basic POH for current weight and balance data. Use the following table to determine the Moment/1000 for deicing fluid to complete the Loading Form in the Weight and Balance Section of the basic POH.

- Total fluid tank capacity is 8.5 gallon (32L).
- Deicing fluid weight is 9.2 pounds per gallon.

Gallons	Weight LB	Mom/1000@ Tank (FS148.0)	Gallons	Weight LB	Mom/1000@ Tank (FS148.0)	Gallons	Weight LB	Mom/1000@ Tank (FS148.0)
0.1	0.9	0.14	3.3	30.4	4.49	6.5	59.8	8.85
0.2	1.8	0.27	3.4	31.3	4.63	6.6	60.7	8.99
0.3	2.8	0.41	3.5	32.2	4.77	6.7	61.6	9.12
0.4	3.7	0.54	3.6	33.1	4.90	6.8	62.6	9.26
0.5	4.6	0.68	3.7	34.0	5.04	6.9	63.5	9.40
0.6	5.5	0.82	3.8	35.0	5.17	7.0	64.4	9.53
0.7	6.4	0.95	3.9	35.9	5.31	7.1	65.3	9.67
0.8	7.4	1.09	4.0	36.8	5.45	7.2	66.2	9.80
0.9	8.3	1.23	4.1	37.7	5.58	7.3	67.2	9.94
1.0	9.2	1.36	4.2	38.6	5.72	7.4	68.1	10.08
1.1	10.1	1.50	4.3	39.6	5.85	7.5	69.0	10.21
1.2	11.0	1.63	4.4	40.5	5.99	7.6	69.9	10.35
1.3	12.0	1.77	4.5	41.4	6.13	7.7	70.8	10.48
1.4	12.9	1.91	4.6	42.3	6.26	7.8	71.8	10.62
1.5	13.8	2.04	4.7	43.2	6.40	7.9	72.7	10.76
1.6	14.7	2.18	4.8	44.2	6.54	8.0	73.6**	10.89
1.7	15.6	2.31	4.9	45.1	6.67	8.1	74.5	11.03
1.8	16.6	2.45	5.0	46.0*	6.81	8.2	75.4	11.17
1.9	17.5	2.59	5.1	46.9	6.94	8.3	76.4	11.30
2.0	18.4	2.72	5.2	47.8	7.08	8.4	77.3	11.44
2.1	19.3	2.86	5.3	48.8	7.22	8.5	78.2	11.57
2.2	20.2	3.00	5.4	49.7	7.35	*Minimum Dispatch Fluid Qty		
2.3	21.2	3.13	5.5	50.6	7.49	**Usable Tank Capacity		
2.4	22.1	3.27	5.6	51.5	7.62			
2.5	23.0	3.40	5.7	52.4	7.76			
2.6	23.9	3.54	5.8	53.4	7.90			
2.7	24.8	3.68	5.9	54.3	8.03			
2.8	25.8	3.81	6.0	55.2	8.17			
2.9	26.7	3.95	6.1	56.1	8.31			
3.0	27.6	4.08	6.2	57.0	8.44			
3.1	28.5	4.22	6.3	58.0	8.58			
3.2	29.4	4.36	6.4	58.9	8.71			

Section 7 - System Description

The TKS Anti-Ice System can prevent and remove ice accumulation on the flight surfaces by distributing a thin film of ice protection fluid on the wing, horizontal stabilizer, vertical stabilizer, elevator tips, and propeller. The presence of this fluid lowers the freezing temperature on the flight surface below that of the ambient precipitation preventing the formation and adhesion of ice.

The system consists of nine porous panels, propeller slinger ring, windshield spray nozzles, heated stall warning system, ice inspection lights, two proportioning units, two metering pumps, windshield/priming pump, 3-way control valve, filter assembly, in-line strainer, outlet strainers, two fluid tanks with fluid level sensors and low level switches, filler APS and necks, test port assembly, electrical switching, and system plumbing. The system operates on 28 VDC supplied through the 7.5-amp ICE PROTECT A circuit breaker on Main Bus 1 and 5-amp ICE PROTECT B circuit breaker on Essential Bus 2.

Storage and Distribution

Two separate and symmetrical 4.25 gallon (16.1L) deicing fluid tanks are serviced through filler APS located on the upper LH and RH wings. Each tank provides a capacity of 4.0 gallons (15.1L) usable and 0.25 gallons (1.0L) unusable, which provides a total system capacity of 8.1 gallons (16.1L) usable. The tanks are sealed wet bays, integral to the wing structure, bounded by the upper and lower wing skins, main spar web, and the inboard, outboard, and lateral tank ribs. The tanks are vented from the outboard ribs to a NACA style ducts attached to access panels on the lower wing skin, just outboard of the tanks. Course-mesh outlet strainers mounted internal to the tanks prevent large objects from obstructing the tank outlets, while a fine-mesh in-line strainer protects the metering pump and windshield/priming pump from damage by contaminants.

Upon activation, two single-speed metering pumps, mounted below the LH passenger seat, draw fluid from the tank and provide fluid pressure to the system at a constant-volume flow rate. The pumps operate both singularly and in parallel according to system mode selection.

If the system is ON and PUMP BKUP is selected, #1 pump will operate (if not failed) based on the mode setting (NORM or HIGH) while #2 pump operates continuously (PUMP BKUP), causing the range and endurance to decrease from the published values, e.g. selection of HIGH and PUMP BKUP will reduce range and endurance as if MAX were selected.

The manifolds of both metering pumps are connected in series and primed by an integral windshield/priming pump which draws fluid from the tank, through both metering pump manifolds, forcing the fluid to the windshield spray nozzles. In the event the metering pumps cannot prime themselves, the windshield/priming pump can be activated to draw fluid from the tank to prime the metering pump manifolds and to remove any entrapped air between the metering pumps and the fluid tank(s). A normally-closed solenoid located between the windshield pump and spray nozzles prevents fluid back flow to the metering pumps.

From the metering pumps, deicing fluid is pushed through a filter assembly, mounted adjacent to the pumps, and then carried through nylon tubing to the proportioning units located in the cabin floor-forward and empennage.

- The cabin floor-forward proportioning unit distributes fluid to the LH and RH Wing Inboard and Outboard panels and propeller slinger ring assembly.
- The empennage proportioning unit distributes fluid to the horizontal and vertical stabilizer panels and the elevator tip panels.

In addition to distributing fluid to the porous panels and propeller slinger ring, the proportioning units provide an additional, distinct pressure drop to the supply lines such that a specific flow rate is provided to each protected surface.

Porous Panels

The proportioned fluid enters the leading edge panels through the inlet fitting(s) on the inboard end of the wing and elevator tip panels, upper end of the vertical panel, and the outboard end of the horizontal panels. The outer surface of the panels is perforated with very small openings to distribute the deicing fluid along their entire length. The panels contain a porous membrane whose pores are nearly 100 times

smaller than the openings of the outer surface. The leading edge of the panel serves as a reservoir as fluid entering the panel fills the cavity behind the porous membrane then overcomes this resistance to be distributed by the openings in the external surface. The inlet fitting of the inboard wing porous panel also supplies fluid to the porous stall strip through an additional capillary tube which further proportions the fluid to provide a specific flow rate to the stall strip. Each panel incorporates a vent opposite the inlet which provides a relatively large opening to release air from within the panel. A check valve prevents air from entering the panel through the vent which slows the "leak-down" of the panel during periods of inactivity

Windshield Spray Nozzles and Pump

The windshield pump, located adjacent to the main metering pumps beneath the LH passenger seat, supplies fluid to the windshield nozzles. The pump also acts as a priming pump for the main metering pumps. In the event the metering pumps cannot prime themselves, the windshield pump may be activated to purge the system of any entrapped air between the main metering pumps and the fluid tank.

Propeller Slinger Ring

Deicing fluid protects the propeller by a slinger ring mounted to the spinner backing plate where the fluid is distributed by centrifugal action onto grooved rubber boots fitted to the root end of the propeller blades.

Fluid Quantity Sensing

Fluid quantity is measured by a float type quantity sensor installed in the deicing fluid tanks. A single-point fluid level switch is installed near the outlet of each tank to provide a redundant "Empty" indication to prevent the system from drawing air. An ultrasonic flow meter installed between the in-line strainer and the metering pumps continuously senses the system flow rate. The fluid quantity and flow rate information is sent to the Engine Airframe Unit, processed, and transmitted to the Engine Indicating System for display.

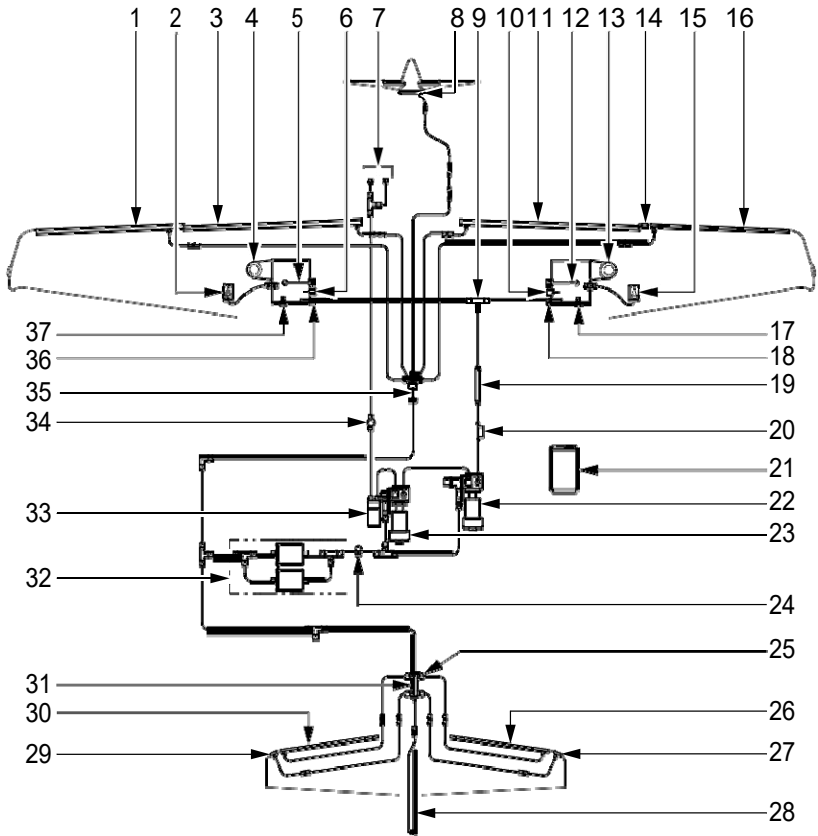

LEGEND

- | | | |
|-----------------------|---------------------------|-----------------------------|
| 1. LH Outbd Panel | 14. Stall Transducer | 27. RH Elevator Tip Panel |
| 2. LH Vent | 15. RH Vent | 28. V Stab Panel |
| 3. LH Inbd Panel | 16. RH Outbd Panel | 29. LH Elevator Tip Panel |
| 4. LH Filler Cap | 17. RH Drain Valve | 30. LH H Stab Panel |
| 5. LH Level Sender | 18. RH Tank Strainer | 31. Tail Proportioning Unit |
| 6. LH Level Switch | 19. In-Line Strainer | 32. Filter Assembly |
| 7. Windshield Nozzles | 20. Flow Transducer | 33. Windshield Pump |
| 8. Slinger Ring | 21. Pump Control Unit | 34. Solenoid Valve |
| 9. 3-Way Valve | 22. Metering Pump 1 | 35. Main Proportioning Unit |
| 10. RH Level Switch | 23. Metering Pump 2 | 36. LH Tank Strainer |
| 11. RH Inbd Panel | 24. High Pressure Switch | 37. LH Drain Valve |
| 12. RH Level Sender | 25. Low Pressure Switches | |
| 13. RH Filler Cap | 26. RH H Stab Panel | |

T1_FM09_2965

Figure - 2
System Schematic

System Control

System operation is controlled by five bolster panel switches and three MFD softkeys:

- Bolster Panel Switches; Metering pump operation and mode control (flow rate) are controlled by the NORM, HIGH, and MAX switches. WINDSHLD controls the windshield pump operation. PUMP BKUP is used in the event of certain system failures.
- MFD Softkeys; Tank selection is provided by three MFD softkeys on the MFD Engine Page. Automatic tank selection is provided by the default, AUTO mode. While the system is operating, the fluid quantity in each tank will be passively balanced by alternating the selected tank using the 3-way control valve.

Mode Control

- NORM controls both pumps to operate quarter-time intermittently to provide 100% flow rate, i.e. 30 seconds on, 90 seconds off.
- HIGH controls #1 pump to operate continuously to provide 200% flow rate, i.e. two times the normal flow rate.
- MAX controls both pumps to operate continuously for 2 minutes to provide 400% flow rate, i.e. four times the normal flow rate. Pump operation then reverts to the system mode selected by the ICE PROTECT Mode Switch.
- WINDSHLD controls the windshield pump to operate continuously for approximately 3 seconds.
- PUMP BKUP controls #2 pump to operate continuously to provide 200% flow rate, i.e. two times the normal flow rate. When pump backup mode is selected, an alternate circuit bypasses the Timer Box and supplies power to the #2 metering pump which in turn operates continuously.

Fluid Tank Control

- AUTO: While the system is operating, the fluid quantity in each tank is passively balanced by the avionics system using the 3-way control valve and the sensed quantity of each tank.
- LEFT: Ice protection fluid is drawn from the left tank regardless of sensed quantity.

- **RIGHT:** Ice protection fluid is drawn from the right tank regardless of sensed quantity.

System Indicating

System Indicating is displayed as bar graphs and text in the lower left corner of the MFD ENGINE page. The bar graphs, marked from 0 to 4 U.S. gallons in 1-gallon increments, indicate LH and RH tank fluid quantity. Fluid quantity is also displayed numerically below the bar graphs in 0.1-gallon increments. When the system is operating in the default, automatic tank selection mode (AUTO), a white box is centered around the “L” and “R” located above each bar graph and a cyan box is displayed around the selected Anti-Ice System mode. During normal operation, the white box will switch between the left and right tank as the fluid level changes. In the case of an electronic display failure (reversionary mode), fluid quantity is displayed along the LH edge of the PFD and the system maintains the tank selection mode that was current when reversionary mode was activated. Manual tank selection mode is selected by pressing the ANTI-ICE softkey to access control of the LEFT and RIGHT tanks. In manual mode, a cyan box is displayed around the selected tank, gallons remaining in that tank, and the selected Anti-Ice System mode. Pressing AUTO returns the system to automatic tank selection mode.

System Endurance is displayed on the MFD ENGINE Page for the different system modes based on the total sensed fluid quantity and published system flow rates. A cyan box depicts the user selected system mode. System Range is displayed on the MFD ENGINE Page for the selected system mode based on the calculated system endurance and the current ground speed.

If tanks are selected manually, system range and endurance calculations use only the sensed fluid quantity of the selected tank. While in PUMP BKUP, system range and endurance calculations use the sensed system flow rate of the flow meter.

Refer to the Integrated Integrated Avionics System Pilot's Guide for additional information on system annunciation and control.

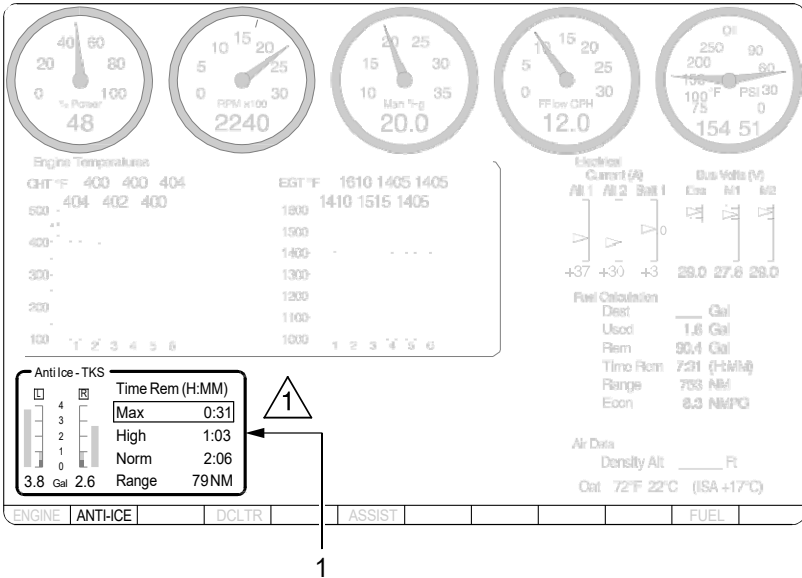

NOTE

1 Illustration depicts system during Auto Tank Mode with LH and RH tanks ON while operating in MAX mode.

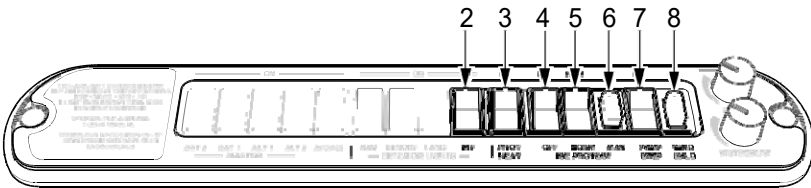

Bolster Panel

LEGEND

- 1. Anti-Ice System Indication
- 2. Ice Inspection Lights
- 3. Pitot and Stall Vane Heat
- 4. Anti-Ice System ON / OFF Switch
- 5. NORM / HIGH Mode Switch
- 6. MAX Mode Push Button
- 7. Pump Backup Switch
- 8. Wind Shield Push Button

T1_FM09_2983

Figure - 3
System Indication and Switching

Stall Warning System

Stall warning is provided by the lift transducer, mounted on the leading edge of the right wing and the stall warning computer located under the cabin floor. The lift transducer senses the force of the airstream on the vane, producing an electrical output to the stall warning computer. When the stall warning set-point is reached, the stall warning computer provides a signal to the avionics system to activate the stall warning aural alert and CAS message. The stall warning computer also provides the information used to generate the dynamic stall speed awareness indication (red band) on the airspeed tape which indicates the relative proximity to the aircraft stall speed based on the wing loading (weight, angle of bank, etc). The stall warning computer operates on 28 VDC supplied through the 5-amp STALL WARNING circuit breaker on the ESS BUS 2.

Ice protection for the lift transducer is provided by two faceplate heaters, one vane heater and one case heater using the PITOT HEAT switch. To prevent overheating during ground operations, a signal from the avionics is used to operate the heaters at 25% power during ground operation or 100% power while in the air. The lift transducer heat is powered by 28 VDC supplied through the 10-amp STALL VANE HEAT circuit breaker on the NON-ESS BUS.

The stall warning computer receives an signal from the avionics system to reduce nuisance stall warning while the aircraft is on the ground. The stall warning is inhibited when ground speed is less than 30 knots or airspeed is less than 55 KIAS. To allow a preflight check of the system, stall warning is enabled if RPM is less than 500 and flaps are set to 100%

An additional stall warning margin is added to the aircraft beyond the required 5 KIAS to account for ice contamination on unprotected surfaces. Although this ensures the required margin is maintained during/after an icing encounter, it may be excessive when the aircraft is not contaminated by ice shapes.

An IPS-ON discrete signal is sent to the stall warning computer when the ice protection system is set to ON. This adds additional stall warning margin to the

aircraft beyond the required 5 KIAS to account for ice contamination on unprotected surfaces. Although this ensures the required margin is maintained during/after an icing encounter, it may be excessive when the aircraft is not contaminated by ice shapes.

Ice-Inspection Lights

To provide visual verification of icing conditions and confirmation of fluid flow, ice inspection lights are flush mounted to the RH and LH fuselage skin just aft of the engine cowling. The bi-directional inspection lights illuminate the leading edge of the wing and horizontal stabilizer. Components of the system include the LED light assemblies and a two-position toggle switch labeled ICE on the Exterior Lights section of the bolster switch panel.

The ice-inspection lights operates on 28 VDC supplied through the 5-amp ICE PROTECT A circuit breaker on MAIN BUS 1.

Section 8 – Handling, Service, & Maintenance

• Caution •

During long periods of non-use, the porous panel membranes may dry out which could cause uneven fluid flow during subsequent operation. Perform the Pre-Flight Inspection every 30 days to keep porous panel membranes wetted.

Use only approved deicing fluid. See Section 2, Limitations. To prevent fluid contamination, maintain a clean, dedicated measuring container and ensure mouth of fluid container is clean before dispensing. Secure the filler cap immediately after filling

Certain solvents may damage the panel membrane. Use only soap and water, isopropyl alcohol, or ethyl alcohol to clean panels. Do not wax leading edge porous panels.

Storage

To prepare the Anti-Ice System for flyable storage, fill the deicing fluid tanks and perform the Pre-Flight Inspection to verify evidence of ice protection fluid along the length of all porous panels. The tanks may then be drained until the next service interval (30 days minimum) or operation of the system is desired.

Servicing

Deicing Fluid Tanks

The deicing fluid tanks are serviced through filler APS in the upper wing skins. Each tank is individually drained and vented by lock-open/lock-close valves in the lower wing skins.

Porous Panels

Periodically clean porous panels with soap and water using a clean, lint-free cloth. Isopropyl alcohol may be used to remove oil or grease.

Metering Pump Priming

If air entered the system due to the fluid tank(s) running dry during system operation, it may require several cycles of the windshield/priming pump to prime the metering pumps.

In the event that the metering pumps cannot prime themselves, the windshield/priming pump may be cycled, 3s ON, 3s OFF, to draw fluid from the tank to prime the metering pump manifolds and to remove any entrapped air between the metering pumps and the fluid tank(s).

Pilot's Operating Handbook and
FAA Approved Airplane Flight Manual
Supplement
for the

GFC 700 Automatic Flight Control System

(Aircraft Serials w/ Integrated Avionics Only)

Including optionally installed Electronic Stability and Protection (ESP), Under-speed Protection (USP), and Hypoxia Detection and Automatic Descent functions.

When the GFC 700 Automatic Flight Control System is installed on the aircraft, this POH Supplement is applicable and must be inserted in the Supplements Section of the basic Pilot's Operating Handbook. This document must be carried in the airplane at all times. Information in this supplement adds to, supersedes, or deletes information in the basic Pilot's Operating Handbook.

• Note •

This POH Supplement Change, dated Revision 03: 12-14-10, supersedes and replaces the Revision 02 release of this POH Supplement dated 01-06-10.

FAA Approved

Joseph C. Miss
for Charles Smalley, Manager

Dec 14 2010
Date

Chicago Aircraft Certification Office, ACE-115C
Federal Aviation Administration

Section 1 - General

The aircraft is equipped with a Garmin GFC 700 Automatic Flight Control System (AFCS) which is fully integrated within the ATPI Integrated Avionics System architecture. Refer to Section 7 - System Description and the ATPI Integrated Pilot's Guide for additional description of the AFCS and operating procedures.

Determining status of Autopilot Under-speed Protection (USP) and Hypoxia Detection and Automatic Descent

If Integrated System software load 0764-09 or later is installed, the aircraft has these functions installed; software load is displayed in the upper RH corner of the first MFD screen presented after power-up.

Determining status of Electronic Stability and Protection (ESP)

If the aircraft is equipped with ESP (software load 0764-09 or later), it is identified and displayed on the second MFD splash screen presented after power-up; this page will state "This aircraft is equipped with Electronic Stability & Protection" if installed.

Section 2 - Limitations

1. The appropriate revision of the ATPI Integrated Cockpit Reference Guide (p/n 190-00821-XX, where X can be any digit from 0 to 9) must be immediately available to the pilot during flight. The system software version stated in the reference guide must be appropriate for the system software version displayed on the equipment.
2. Minimum Autopilot Speed80 KIAS
3. Maximum Autopilot Speed185 KIAS
4. Autopilot Minimum-Use-Height:
 - a. Takeoff and Climb 400 feet AGL
 - b. Enroute and Descent..... 1000 feet AGL
 - c. Approach (GP or GS Mode) Higher of 200 feet AGL or Approach MDA, DA, DH.
 - d. Approach (IAS, VS, PIT or ALT Mode)...Higher of 400 feet AGL or Approach MDA.
5. Yaw Damper must be turned off for takeoff and landing

6. The Autopilot may not be engaged beyond the Engagement Limits. If the Autopilot is engaged beyond the command limits (up to engagement limits) it will be rolled or pitched to within the command limits and an altitude loss of 1000 feet or more can be expected while attitude is established in the selected mode.

Axis	Autopilot Engagement Limit
Pitch	$\pm 30^\circ$
Roll	$\pm 75^\circ$

7. The Autopilot and Flight Director will not command pitch or roll beyond the Command Limits.

Axis	Autopilot Command Limit
FD Pitch Command Limits	+20°, -15°
FD Roll Command Limits	$\pm 25^\circ$

8. Use of VNAV is not supported during an approach with a teardrop course reversal. VNAV will be disabled at the beginning of the teardrop.
9. For aircraft with optional USP, If Stall Warning is inoperative, Autopilot Under-speed Protection will not be provided in Altitude Critical Modes (ALT, GS, GP, TO and GA)

Section 3 - Emergency Procedures

Autopilot Malfunction

Refer to *Electric Trim/Autopilot Failure* abnormal procedure in the basic POH. Do not reengage the Autopilot until the malfunction has been identified and corrected. The Autopilot may be disconnected by:

1. Pressing the A/P DISC on the control yoke.,
or
2. Pulling the AP SERVOS circuit breaker on MAIN BUS 1.

Altitude lost during a roll or pitch axis Autopilot malfunction and recovery:

Flight Phase	Bank Angle	Altitude Loss
Climb	45°	300 ft
Cruise	45°	300 ft
Maneuvering	45°	300 ft
Descent	45°	300 ft
Approach	45°	70 ft

Section 3A - Abnormal Procedures

Altitude Mis-compare

ALT MISCOMP Caution

ALT MISCOMP

For dual ADC installations, altitude difference is greater than 200 feet between ADC1 and ADC2.

1. Altitude..... CROSS-CHECK ADC1 against Standby Altimeter
2. ADC2 SELECT
 - a. Press SENSOR softkey on PFD, followed by ADC2 softkey.
 - b. Expect USING ADC2 message on PFD
3. Altitude..... CROSS-CHECK ADC2 against Standby Altimeter
4. ADC SELECT more reliable
 - a. Press SENSOR softkey, then select the ADC that provided the most reliable altitude indication

Airspeed Mis-compare

IAS MISCOMP Caution

IAS MISCOMP

For dual ADC installations, airspeed difference is greater than 7 knots between ADC1 and ADC2.

1. Airspeed..... CROSS-CHECK ADC1 against Standby Airspeed Indicator
2. ADC2 SELECT
 - a. Press SENSOR softkey on PFD, followed by ADC2 softkey
 - b. Expect USING ADC2 message on PFD
3. Airspeed..... CROSS-CHECK ADC2 against Standby Airspeed Indicator
4. ADC SELECT more reliable
 - a. Press SENSOR softkey, then select the ADC that provided the most reliable airspeed indication

Heading Mis-compare

HDG MISCOMP Caution

HDG MISCOMP

For dual AHRS installations, heading difference is greater than 6° between AHRS 1 and AHRS 2.

1. Heading.....CROSS-CHECK AHRS1 against Magnetic Compass
2. AHRS2.....SELECT
 - a. Press SENSOR softkey on PFD, followed by AHRS2 softkey
 - b. Expect USING AHRS2 message on PFD
3. Altitude.....CROSS-CHECK AHRS2 against Magnetic Compass
4. AHRS.....SELECT more reliable
 - a. Press SENSOR softkey, then select the AHRS that provided the most reliable heading indication

Pitch Mis-compare

PIT MISCOMP Caution

PIT MISCOMP

For dual AHRS installations, pitch difference is greater than 5° between AHRS 1 and AHRS 2. Flight Director, Autopilot, and ESP (if installed) will not be available when pitch mis-compare exists.

1. Pitch.....CROSS-CHECK AHRS1 against Stdby Attitude Indicator
2. AHRS2.....SELECT
 - a. Press SENSOR softkey on PFD, followed by AHRS2 softkey
 - b. Expect USING AHRS2 message on PFD
3. Pitch.....CROSS-CHECK AHRS2 against Stdby Attitude Indicator
4. AHRS.....SELECT more reliable
 - a. Press SENSOR softkey, then select the AHRS that provided the most reliable pitch indication
5. UNRELIABLE AHRS CIRCUIT BREAKER.....PULL
Pulling circuit breaker for unreliable AHRS will clear mis-

compare condition, but will result in 'NO PIT/ROLL/HDG
COMPARE'

advisory since backup source is not available for comparison. Flight Director, Autopilot and ESP will become available when unreliable AHRS CB is pulled.

Roll Mis-compare

ROLL MISCOMP Caution

ROLL MISCOMP

For dual AHRS installations, roll (bank) difference is greater than 6° between AHRS 1 and AHRS 2.

1. Roll.....CROSS-CHECK AHRS1 against Stdby Attitude Indicator
2. AHRS2.....SELECT
 - a. Press SENSOR softkey on PFD, followed by AHRS2 softkey
 - b. Expect USING AHRS2 message on PFD
3. Roll.....CROSS-CHECK AHRS2 against Stdby Attitude Indicator
4. AHRS.....SELECT more reliable
 - a. Press SENSOR softkey, then select the AHRS that provided the most reliable roll indication
5. UNRELIABLE AHRS CIRCUIT BREAKER.....PULL

Pulling circuit breaker for unreliable AHRS will clear mis-compare condition, but will result in 'NO PIT/ROLL/HDG COMPARE' advisory since backup source is not available for comparison. Flight Director, Autopilot and ESP will become available when unreliable AHRS CB is pulled.

Autopilot Mis-compare

AP MISCOMP Caution

AP MISCOMP

Autopilot mis-compare, Autopilot is not available.

1. Continue flight without Autopilot or isolate and remove the unreliable sensor to clear the MISCOMP as described for ROLL or PIT MISCOMP checklists to restore the autopilot.

Autopilot and PFD Using Different AHRSs

AP/PFD AHRS Caution

AP/PFD AHRS

The Autopilot and PFD are using different Attitude and Heading Reference Systems.

1. Continue flight without Autopilot. Monitor Standby Instruments. Pilot may manually select other AHRS if installed.

No Autopilot ADC Modes Available

NO ADC MODES Caution

NO ADC MODES

Autopilot air data modes are not available.

1. Autopilot may only be engaged in pitch (PIT) mode.

No Autopilot Vertical Modes Available

NO VERT MODES Caution

NO VERT MODES

Autopilot vertical modes are not available.

1. Autopilot may only be engaged in lateral mode.

Altitude Selection Deviation

ALTITUDE SEL Advisory

ALTITUDE SEL

The pilot has programmed the Autopilot to climb or descend away from the selected altitude. Typically done unintentionally.

1. Altitude SelectionCORRECT, AS REQUIRED

Course Selection Track Error

COURSE SEL Advisory

COURSE SEL

The pilot has selected an Autopilot mode (ROL) and engaged a NAV mode (VLOC or GPS) and the current aircraft track will not intercept the selected course. Typically done unintentionally.

1. Course Heading..... CORRECT, AS REQUIRED

Autopilot Hypoxia Detection System (Optional)

ARE YOU ALERT? Advisory

ARE YOU ALERT?

No pilot activity has been detected over a prescribed interval of time, interval decreases as altitude increases.

1. Actuate any Integrated Avionics System softkey or knob to reset system.

HYPOXIA ALERT Caution

HYPOXIA ALERT

No pilot response to the ARE YOU ALERT? annunciation detected after one minute.

1. Actuate any Integrated Avionics System softkey or knob to reset system.

AUTO DESCENT Warning

AUTO DESCENT

No pilot response to the HYPOXIA ALERT annunciation detected after one minute. Warning remains until pilot responds. Automatic descent begins after one minute of unanswered Warning. Once it begins automatic descent will commence to 14,000 for 4 minutes, then to 12,500' thereafter. Once descent begins, only a decouple of the Autopilot will interrupt this process.

1. If within 60 seconds of AUTO DESCENT Warning (prior to descent):
 - a. Actuate Integrated Avionics System softkey or knob to reset.
2. If greater than 60 seconds of AUTO DESCENT Warning:
 - a. Autopilot.....DISCONNECT
 - b. Situation..... ASSESS

• WARNING •

Pilot should carefully asses aircraft state, altitude, location, and physiological fitness to maintain continued safe flight.

- c. ATCCOMMUNICATE SITUATION
 - d. ALT Bug RESET to desired
 - e. Autopilot.....ENGAGE
- If hypoxia suspect:*
- f. Oxygen Masks or CannulasDON
 - g. Oxygen System ON
 - h. Oxygen Flow Rate MAXIMUM
 - i. Blood Oxygen Saturation Level CHECK

Under-speed Protection Recovery (Optional)

UNDERSPEED PROTECT ACTIVE Warning

**UNDERSPEED
PROTECT ACTIVE**

Autopilot engaged and airspeed has fallen below minimum threshold.

Recovery may be initiated in one of three ways:

1. Power LeverINCREASE
as required to correct under-speed condition.
or
1. Autopilot AP DISC Switch SELECT
and manually fly aircraft.
or
1. Autopilot CHANGE MODES
to one in which the AFCS can maintain.

Section 4 - Normal Procedures

• Note •

Normal operating procedures for the GFC 700 Automatic Flight Control System are described in the ATPI Integrated Pilot's Guide.

Pre-Flight Inspection

1. A self-test is performed upon power application to the AFCS. A boxed AFCS annunciator will appear on the PFD in white text on a red background, followed by a boxed PFT in black text on a white background. Successful completion is identified by all Mode Controller annunciators illuminating for two seconds.

Before Taxiing

1. Manual Electric Trim.....TEST
Press the AP DISC button down and hold while commanding trim. Trim should not operate either nose up or nose down.
2. AutopilotENGAGE (press AP button)
3. Autopilot OverrideTEST
Move flight controls fore, aft, left and right to verify that the Autopilot can be overpowered.
4. AutopilotDISENGAGE (press AP button)
5. Trim SET FOR TAKEOFF

Enabling/Disabling ESP (Optional)

1. Turn the large FMS Knob to select the AUX page group
2. Turn the small FMS Knob to select the System Setup Page.
3. Press the SETUP 2 Softkey.
4. Press the FMS Knob momentarily to activate the flashing cursor.
5. Turn the large FMS Knob to highlight the 'Status' field in the Stability & Protection Box.
6. Turn the small FMS Knob to select 'ENABLED' or 'DISABLED'.
7. Press the FMS Knob momentarily to remove the flashing cursor.

Temporary Interrupt of ESP (Optional)

Although ESP is only provided when AFCS Autopilot is disengaged, the AFCS and its servos are the source of ESP guidance. When the AP Disconnect button is pressed and held, the servos will provide no ESP control force feedback. Upon release of the AP Disconnect button, ESP will be restored.

1. AP DisconnectPRESS and HOLD until maneuver complete

Section 5 - Performance

• WARNING •

The Autopilot may not be able to maintain all selectable vertical speeds. Selecting a vertical speed that exceeds the aircraft's available performance may cause the aircraft to stall.

If AFCS Under-speed Protection function is not installed, the Autopilot will disconnect if the Stall Warning System is activated.

Section 6 - Weight & Balance

Refer to Section 6 - Weight and Balance of the basic POH.

Section 7 - System Description

This airplane is equipped with a GFC 700 - a two axis (three axis optional), fully digital, dual channel, fail passive Automatic Flight Control System (AFCS). The system consists of the GFC 705 AFCS Mode Controller, Flight Management System Keyboard, Roll Servo, Pitch Servo, Yaw Servo (optional), Integrated Avionics Units, Pitch Trim Adapter, Autopilot Disconnect Switch, Take Off / Go Around Button, Electric Pitch-Trim and Roll-Trim Hat Switch. The GFC 700 AFCS with optional Yaw Damper can be divided into three primary operating functions:

Flight Director - The Flight Director provides pitch and roll commands to the AFCS system and displays them on the PFD. With the Flight Director activated, the pilot can hand-fly the aircraft to follow the path shown by the command bars. Flight Director operation takes place within the #1 Integrated Avionics Unit and provides:

- Mode annunciation
- Vertical reference control
- Pitch and roll command calculation
- Pitch and roll command display

Autopilot - The Autopilot controls the aircraft pitch, roll, and if installed, yaw attitudes, while following commands received from the Flight Director. Autopilot operation occurs within the trim servos and provides:

- Autopilot engagement and annunciation
- Autopilot command and control
- Auto-trim operation
- Manual electric trim
- Two axis airplane control (pitch and roll), including approaches
- Level (LVL) mode engagement command of zero roll and zero vertical speed.

Optional Yaw Damper - Yaw Damper operation is provided by the yaw servo and supplies:

- Yaw Damper engagement and annunciation
- Yaw axis airplane control

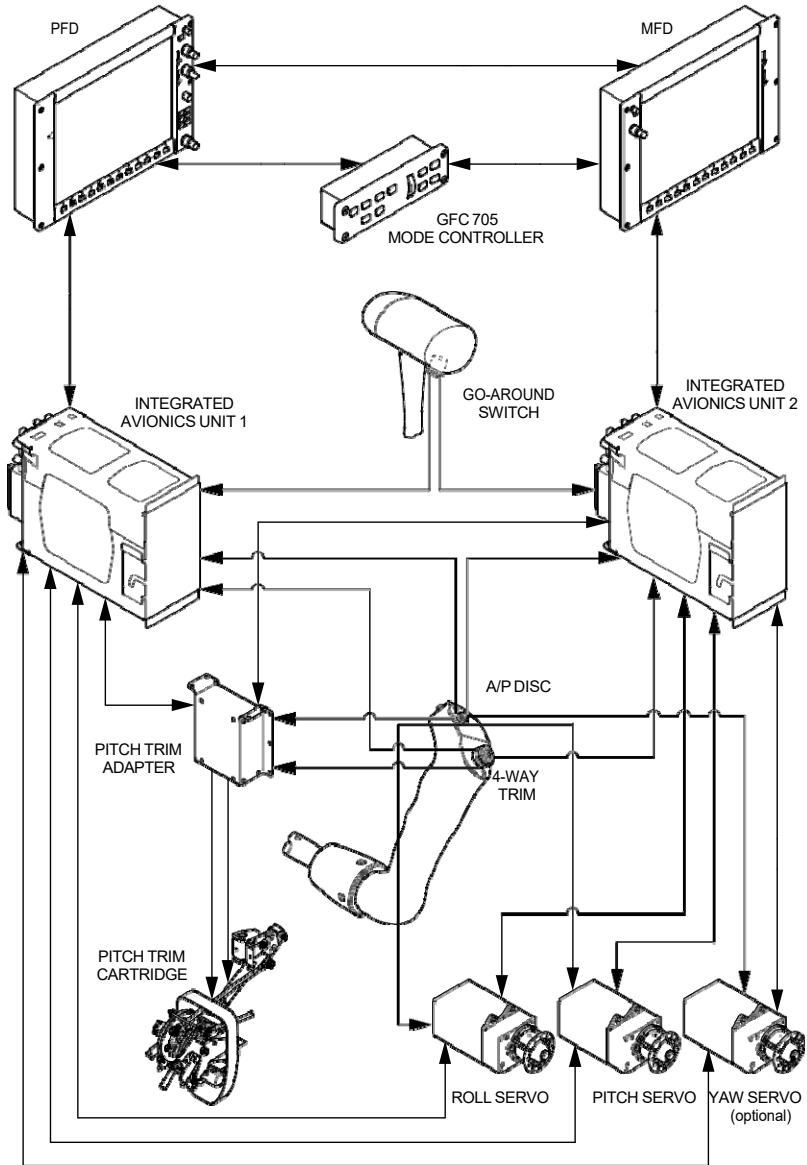

T1_FM09_2919

Figure - 1
GFC 700 Automatic Flight Control System Schematic

GFC 705 AFCS Mode Controller

The GFC 705 AFCS Mode Controller, located in the upper section of the center console, provides primary control of Autopilot modes and, if installed, yaw damper engagement. A pitch wheel is included for adjustment of pitch mode reference. 28 VDC for GFC 705 AFCS Mode Controller operation is supplied through 5-amp KEYPADS / AP CTRL circuit breaker on MAIN BUS 1. All Autopilot mode selection is performed by using the mode select buttons and pitch wheel on the controller. Available functions are as follows:

HDG - Heading Button

The HDG hold button selects/deselects the Heading Select mode. Heading Select commands the Flight Director to follow the heading bug (selected with the HDG knob).

NAV - Navigation Button

The NAV button selects/deselects the Navigation mode. This provides lower gains for VOR enroute tracking and disables glideslope coupling for localizer or back course approaches and glideslope coupling for GPS approaches. This button is also used to couple to the GPS.

APR - Approach Button

The APR button selects the Approach mode. This provides higher gains for VOR approach tracking and enables glideslope coupling for ILS approaches and GPS coupling for LPV (Localizer Performance with Vertical Guidance) and LNAV +V approaches.

AP - Autopilot Button

The AP button engages/disengages the Autopilot.

LVL - Level Button

The LVL button engages the Autopilot (within the Autopilot Engagement Limits if not already engaged) and commands roll to zero bank angle and pitch to zero vertical speed. The LVL button will not engage, or will disengage, if the Stall Warning System is activated.

FD - Flight Director Button.

The FD button toggles the Flight Director activation. It turns on the Flight Director in the default pitch and roll modes if no modes were previously selected. Pressing the FD button with command bars in view, will deactivate the Flight Director and remove the command bars unless the Autopilot is engaged. If the Autopilot is engaged, the FD button is deactivated.

YD - Yaw Damper Button (Optional)

The YD button engages/disengages the yaw damper.

• Note •

The yaw damper is automatically engaged when the Autopilot is engaged with the AP button.

UP/DN - Pitch Wheel

The Pitch UP/DN Wheel on the controller is used to change the Flight Director pitch mode reference value. Each click of the wheel results in a step increase or decrease in the Flight Director pitch mode by the amount shown in the table below. The Pitch Wheel controls the reference for Pitch Hold (PIT), Vertical speed (VS), and Indicated Airspeed (IAS) FD modes. The reference value is displayed next to the active mode annunciation on the PFD. Go-Around and Glide-scope modes are not controlled by the nose Pitch Wheel, however, use of the Pitch Wheel during Go-Around mode will cause reversion to Pitch Hold mode. The Pitch Wheel controls altitude reference when in altitude hold mode.

Flight Director Mode	Step Value
Default Pitch Hold (PIT)	0.50 Degree
Vertical speed (VS)	100 Feet per Minute
Indicated Airspeed (IAS)	1 Knot
Altitude Hold (ALT)	10 Feet

IAS - Indicated Airspeed Hold Button

The IAS button selects/deselects the Indicated Airspeed Hold mode.

ALT - Altitude Button

The ALT hold button selects/deselects the Altitude Hold mode.

VS - Vertical Speed Button

The VS button selects/deselects the Vertical Speed mode.

VNV - VNAV Button

The VNV button selects/deselects the Vertical Navigation mode.

Flight Management System Keyboard

The Flight Management System Keyboard, found in the center console below the AFCS mode controller, is the primary means for data entry for the MFD and is used to control NAV/COM Radios, transponder, and flight management system entry. Heading, course and altitude select are also provided.

28 VDC for Flight Management System Keyboard operation is supplied through the 5-amp KEYPADS / AP CTRL circuit breaker on MAIN BUS 1.

AFCS related functions are as follows:

HDG - Heading Knob.

The HDG knob controls the selected heading bug on the HSI portion of the PFD. It provides the reference for heading select mode. Pushing the HDG knob synchronizes the selected heading to the current heading.

CRS - Course Knob

The CRS knob controls the course pointer on the HSI portion of the PFD. It provides the reference for FD navigation modes when the Flight Director is selected. Pushing the CRS knob re-centers the CDI and returns the course pointer to the bearing of the active waypoint or navigation station.

ALT SEL - Altitude Select Knob

The ALT knob controls the Selected Altitude, which is used as the reference for the altitude alerter and the altitude capture function. Pushing the ALT SEL knob synchronizes the selected altitude to the displayed altitude to the nearest 10 ft.

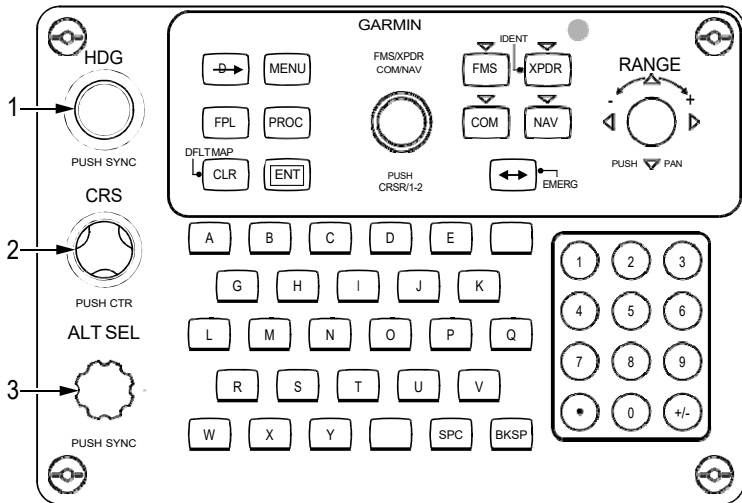

Flight Management System Keyboard

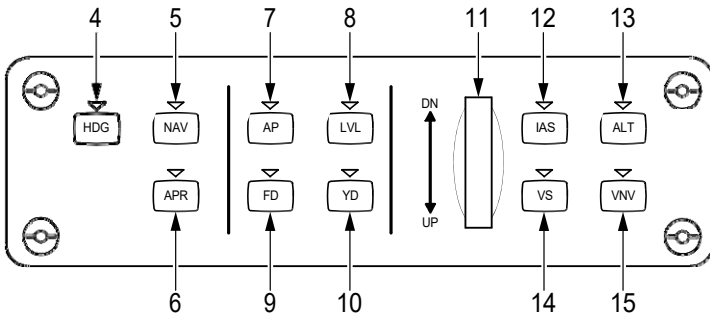

GFC 705 Mode Controller

Legend

- | | |
|------------------------|------------------------------|
| 1. Heading Selection | 9. Flight Director |
| 2. Course Selection | 10. Yaw Damper (optional) |
| 3. Altitude Selection | 11. Pitch Wheel |
| 4. Heading Select Mode | 12. Indicated Airspeed Hold |
| 5. Navigation Mode | 13. Altitude Hold |
| 6. Approach Mode | 14. Vertical Speed Mode |
| 7. Autopilot | 15. Vertical Navigation Mode |
| 8. Wings Level | |

T1_FM09_2921

Figure - 2
FMS Keyboard and GFC 705 AFCS Mode Controller

Roll, Pitch and Optional Yaw Servo

The Roll Servo, located below the passenger seat, the Pitch Servo, located below the baggage compartment, and the optional Yaw Servo, located in the empennage avionics bay, position the aircraft flight controls in response to commands generated by the Integrated Avionics Units Autopilot calculations.

28 VDC for Roll and Pitch Servo operation is supplied through the 5-amp AP SERVOS circuit breaker on MAIN BUS 1.

28 VDC for Yaw Servo operation is supplied through the 3-amp AP YAW SERVO circuit breaker on MAIN BUS 3.

Integrated Avionics Units

The Integrated Avionics Units located behind the MFD and instrument panel, function as the main communication hubs to the Avionics System and GFC 700, linking the systems to the PFD and MFD displays. Each Integrated Avionics Unit receives air and attitude data parameters from the Air Data Computer and Attitude and Heading Reference System. Each Integrated Avionics Unit contains a GPS WAAS receiver, VHF COM/NAV/GS receivers, and system integration microprocessors. The AFCS function within the Integrated Avionics Units control the active and armed modes for the Flight Director, as well as Autopilot engagement. The Flight Director commands for the active modes are calculated and sent to the PFD for display and mode annunciation. The sensor data and Flight Director commands are also sent to the servos over a common serial data bus.

28 VDC for Integrated Avionics Unit 1 operation is supplied through the 7.5-amp COM 1 and 5-amp GPS NAV1 circuit breakers on the ESS BUS 1. 28 VDC for Integrated Avionics Unit 2 operation is supplied through the 7.5-amp COM 2 and 5-amp GPS NAV2 circuit breakers on the MAIN BUS 2.

Autopilot Disconnect Switch

The yoke mounted Autopilot Disconnect (AP DISC) Switch disengages the Autopilot and may also be used to mute the aural alert associated with an Autopilot Disconnect.

For ESP equipped aircraft, the Autopilot Disconnect Switch will also temporarily suspend the servo's from providing ESP correction forces, thus having an "interrupt" function. This may be useful to alleviate

control forces if intentional maneuvers are necessary beyond ESP's engagement threshold (i.e., isolated training maneuvers).

Take Off / Go Around Button

The remote TO/GA switch, located on the left side of the power lever, selects the Takeoff or Go Around mode on the Flight Director. When the aircraft is on the ground, pressing the TO/GA switch engages the Flight Director command bars in Takeoff (TO) mode. When the aircraft is in the air, pressing the TO/GA switch engages the Flight Director command bars in Go Around (GA) mode and cancels all armed modes except ALT ARM (ALTS).

• Note •

For aircraft *without* USP, selection of the TO/GA switch will also disengage the autopilot.

For aircraft *with* USP, selection of TO/GA switch will not change autopilot engagement (i.e., if initially engaged, autopilot will remain engaged; if initially not engaged, autopilot will remain not engaged).

After TO/GA engagement, other roll modes may be selected and Autopilot engagement is allowed. However, an attempt to modify the pitch attitude with the Pitch Wheel will result in a reversion to PIT mode. Additionally, if in Approach mode, pressing the TO/GA switch resumes automatic sequencing of waypoints by deactivating the "SUSP" mode.

For aircraft with optional USP function, if power is insufficient to maintain go-around attitude, the Autopilot will enter Under-speed Protection Mode.

Pitch Trim Adapter

The Pitch Trim Adapter, located below the passenger seat, takes input from the trim switches, Integrated Avionics Units, and the pitch servos to allow the GFC 700 to drive the pitch trim cartridge.

28 VDC for Pitch Trim Adapter operation is supplied through the 2-amp PITCH TRIM circuit breaker on Main Bus #1.

Electric Pitch/Roll-Trim Hat Switch

The yoke mounted Electric Pitch Trim and Roll Trim Hat Switch allows the pilot to manually adjust aircraft trim when the Autopilot is not engaged.

Electronic Stability and Protection (Optional)

When installed, Electronic Stability and Protection (ESP) assists the pilot in maintaining the airplane in a safe flight condition. Through the use of the GFC 700 AFCS sensors, processors, and servos, ESP provides control force feedback, i.e. a “soft barrier”, to maintain the aircraft within the pitch, roll, and airspeed flight envelope by automatically engaging one or more servos when the aircraft is near the defined operating limit.

This feature is only active when in flight and the GFC 700 Autopilot is off. The ESP engagement envelope is the same as the Autopilot engagement envelope and is not provided beyond the Autopilot engagement limits.

The pilot can interrupt ESP by pressing and holding the Autopilot Disconnect (AP DISC) button. If frequent maneuvers are necessary beyond the engagement threshold, such as commercial pilot training, the system can be disabled from AUX/SETUP 2 page. Disabling will cause the ESP OFF advisory to annunciate. The system can be re-enabled from the same page, or is automatically re-enabled at the next system power-up.

Pitch and Roll Modes

When the aircraft reaches the pitch and/or roll engagement limit, the system commands the servos to apply a supplemental stick force back toward the nominal attitude range. If the aircraft continues to pitch and/or roll away from the nominal attitude range, stick forces will increase with increasing attitude deviation until the maximum Autopilot engagement limits are reached - at which point ESP will disengage.

ESP attempts to return the aircraft to the nominal attitude range not to a specific attitude. As the attitude returns to the nominal range, the stick forces and attitude rate change are reduced until the aircraft reaches the disengagement threshold and ESP becomes inactive. The disengagement threshold is sized so that the transition from ESP being active to being inactive is transparent to the pilot.

Roll protection engagement limits are annunciated on the PFD as double ticks at 45° roll attitude. If the aircraft exceeds 45° roll attitude ESP becomes engaged and these indicators migrate to 30° roll attitude denoting the disengagement threshold - the point at which stick forces will be removed. No PFD annunciation is provided during pitch ESP engagement.

Roll Protection Limits:

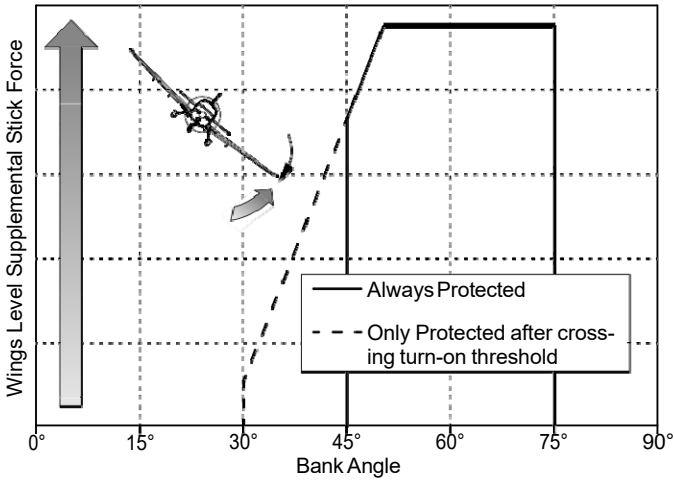

T1_FM09_3399

Engagement Limit:45°

Maximum Stick Force attained at.....50°

Disengagement Threshold (Zero Stick Force).....30°

High Pitch Protection Limits

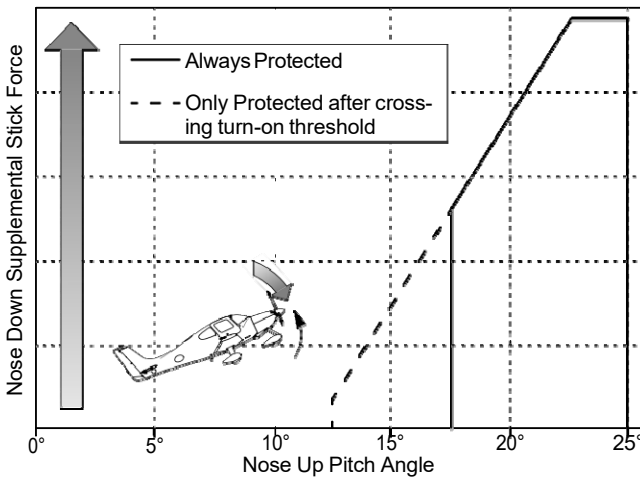

T1_FM09_3403

Engagement Limit:+17.5°

Maximum Stick Force attained at.....+22.5°

Disengagement Threshold (Zero Stick Force):.....+12.5°

Low Pitch Protection Limits

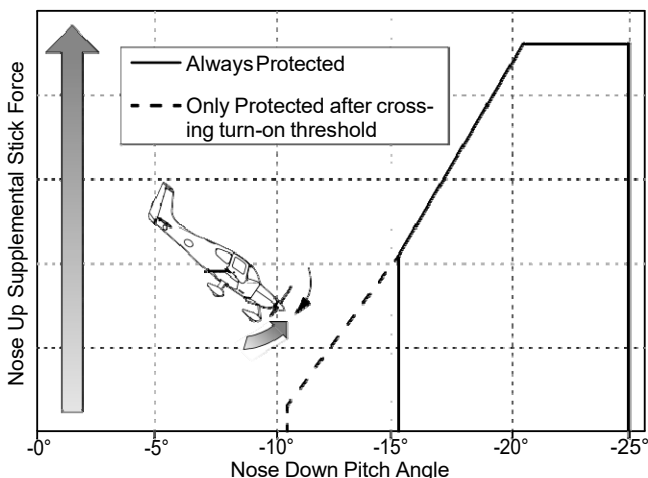

T1_FM09_3426

Engagement Limit:.....-15.5°
 Maximum Stick Force attained at:.....-20.5°
 Disengagement Threshold (Zero Stick Force).....-10.5°

High Airspeed Mode

To protect against an overspeed condition, the High Airspeed Mode uses engagement limits, thresholds, and stick forces similar to those used for the pitch and roll modes, but is instead triggered by airspeed and controlled by pitch attitude. When the aircraft reaches the ESP engagement limit, the system commands the pitch servo to apply a supplemental stick force back toward the nominal airspeed range.

• Note •

For turbocharged equipped aircraft, V_{ne} reduces above 17,500 ft PA to follow a Mach limit of 0.42.

At high altitudes Mach number determines the threshold.

High Airspeed Protection Limits - Below 17,500 ft PA

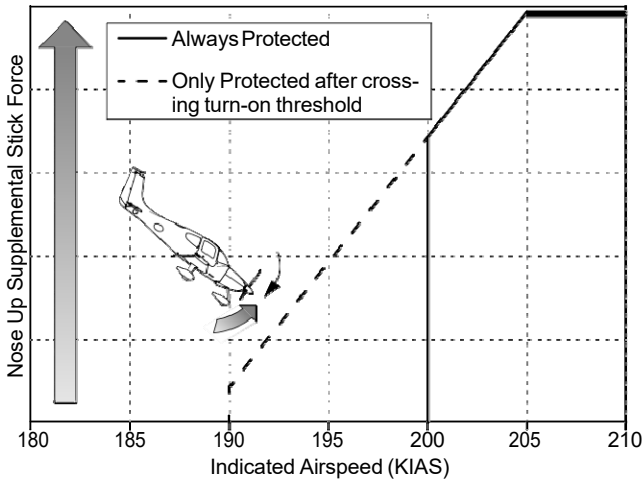

T1_FM09_3405

Engagement Limit:.....200 KIAS
 Maximum Stick Force attained at:.....205 KIAS
 Disengagement Threshold (Zero Stick Force).....190 KIAS

High Airspeed Protection Limits - Above 17,500 ft PA

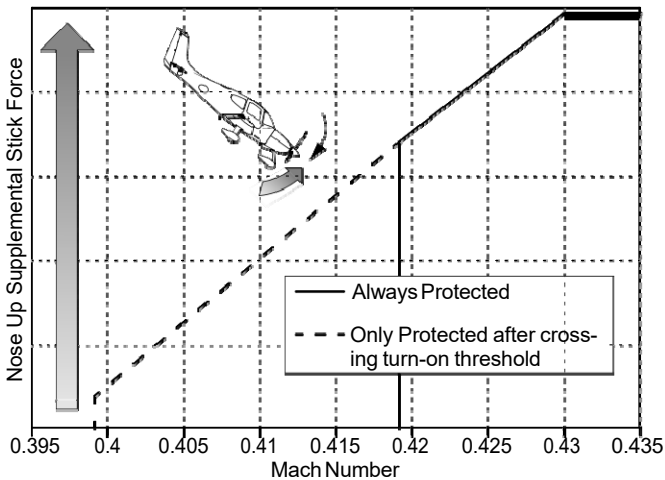

T1_FM09_3428

Engagement Limit:.....Mach 0.419
 Maximum Stick Force attained at:.....Mach 0.430
 Disengagement Threshold (Zero Stick Force).....Mach 0.399

Under-speed Protection Mode (Optional)

When installed, to discourage aircraft operation below minimum established airspeeds the AFCS will automatically enter Under-speed Protection Mode when the Autopilot is engaged and airspeed falls below the minimum threshold. If aircraft stall warning system is not operational, autopilot under-speed protections that depend on that system will also not be functional (affects altitude critical modes only: ALT, GS, GP, TO, and GA).

As described in the following table, when the aircraft reaches predetermined airspeeds a yellow MINSPD annunciation will appear above the airspeed indicator and a single aural "AIRSPEED" will sound to alert the pilot to an impending under-speed condition.

Anti-Ice System	Flaps	MINSPD Annunciations	Aural Alert Annunciations
OFF	0%	80 KIAS	85 KIAS
	50%	76 KIAS	80 KIAS
	100%	70 KIAS	80 KIAS
ON	0%	85 KIAS	90 KIAS
	50%	81 KIAS	85 KIAS

The system differentiates two types of vertical modes based on which vertical Flight Director mode is selected; Altitude-Critical - where terrain hazards are more probable and minimized altitude loss is critical and Non-Altitude Critical - which generally correspond with activities that can afford exchange of altitude for airspeed without introducing terrain hazards.

Altitude-Critical Mode (ALT, GS, GP, GA, TO)

Upon stall warning system activation, the AFCS will abandon its Flight Director and Autopilot reference modes and sacrifice altitude for airspeed. The system will hold wings level and airspeed will progressively increase by 1 knot per second until stall warning becomes inactive. The system will then increase airspeed an additional 2 knots above the speed at which the stall warning discontinued. Recovery may be initiated in one of three ways:

1. Add sufficient power to recover to a safe flight condition.

If a small power addition is made, the AFCS will pitch the aircraft to maintain speed reference. If a large power addition is made the

AFCS recognizes it via acceleration and the AP/FD will transition to a nose-up pitch to aggressively return to original altitude or glidepath/slope.

2. Disengage Autopilot via AP DISC and manually fly.
3. Change Autopilot modes to one in which the AFCS can maintain (such as VS with a negative rate).

Non-Altitude Critical Mode (VS, PIT, VNAV, LVL, IAS)

For all non-altitude critical modes the Autopilot will maintain its original reference (VS, PIT, etc...) until airspeed decays to a minimum airspeed (MINSPD). Crew alert and annunciation during a non-altitude critical under-speed event are similar to an altitude-critical event, except that;

- Stall warning may not be active. Depending on load tolerances, the AP/FD may reach the minimum airspeed reference and take under-speed corrective action before stall warning occurs. If stall warning does coincide or precede the aircraft reaching its minimum airspeed reference, it has no influence - only airspeed affects the AP/FD in non-altitude critical events.
- The originally selected lateral mode remains active.

Upon reaching minimum airspeed, the AFCS will abandon its Flight Director and Autopilot reference modes and maintain this airspeed until recovery. As with altitude-critical modes, available options for recovery are add power, decouple/manually fly, or change Autopilot modes.

When adding power, unlike the altitude-critical modes, which performs an aggressive recovery, the AP/FD will maintain MINSPD until the original reference can be maintained. Non-altitude critical modes will maintain the originally selected lateral mode (HDG, NAV, etc...).

Coupled Go-Around

Airplanes equipped with Under-speed Protection Mode are capable of flying fully coupled go-around maneuvers. Pressing the GA button on the throttle will not disengage the Autopilot. Instead, the Autopilot will attempt to capture and track the Flight Director command bars. If insufficient airplane performance is available to follow the commands, the AFCS will enter Altitude-Critical Mode when the stall warning sounds.

Hypoxia Detection and Automatic Descent (Optional)

When installed, the AFCS Hypoxia Detection and Automatic Descent function monitors pilot inputs to the Integrated Avionics System to identify if a pilot has become incapacitated due to hypoxia, and upon determination, automatically descends to a lower altitude where pilot recovery is more probable. The feature is only available when the GFC 700 Autopilot is engaged and the aircraft is above 14,900 ft PA.

Mode of Operation

Pilot interaction with the Integrated Avionics System is monitored by detecting key presses and turns of the knobs. If the pilot has not made a system interaction within a defined interval - based on altitude and time of useful consciousness - the AFCS prompts the pilot for a response with an ARE YOU ALERT? CAS Advisory.

If no pilot response to the Advisory is detected, after one minute the AFCS annunciates an HYPOXIA ALERT Caution and a double chime aural alert.

After one minute, if no response to the Caution is detected the system annunciates an AUTO DESCENT Warning and continuous aural warning tone.

Lack of response after one minute of Warning annunciation is considered evidence of pilot incapacitation. The AFCS will automatically engage emergency descent mode (EDM) as follows:

1. EDM will annunciate in the AFCS status window.
2. The altitude bug will be automatically set to 14,000 ft indicated.
3. The airspeed bug will be set to the maximum commandable Autopilot speed - i.e., the lesser of 185 KIAS or Mach 0.420.
4. The Autopilot vertical mode will change to IAS, and initiate a descent to intercept 14,000 ft indicated.

Once descent begins only Autopilot Disconnect (AP DISC) will interrupt this process. Autopilot lateral mode remains unchanged throughout the descent and the aircraft will continue on its previously selected course or heading. After reaching 14,000 ft indicated, the aircraft will maintain this flight level for 4 additional minutes. If the pilot does not acknowledge the Warning and resume control of the aircraft, the AFCS will automatically perform a secondary descent to 12,500 ft PA at 185 KIAS. An altitude of 12,500 ft PA will be maintained if the pilot remains unresponsive

Annunciation System

• Note •

Refer to the ATPI Integrated Pilot's Guide for a detailed description of the annunciator system and all warnings, cautions and advisories.

Crew Alerting System

AFCS alerts are displayed in the Crew Alerting System (CAS) window located to the right of the altimeter and VSI. AFCS annunciations are grouped by criticality and sorted by order of appearance with the most recent message on top. The color of the message text is based on its urgency and required action:

- Warning (red) – Immediate crew awareness and action required.
- Caution (yellow) – Immediate crew awareness and future corrective action required.
- Advisory (white) – Crew awareness required and subsequent action may be required.

In combination with the CAS Window, the system issues an audio alert when specific system conditions are met and an expanded description of the condition is displayed in the Alerts Window located in the lower RH corner of the PFD.

• Note •

For specific pilot actions in response to AFCS alerts, refer to Section 3A - Abnormal Procedures.

AFCS Status Box and Mode Annunciation

Flight Director mode annunciations are displayed on the PFD when the Flight Director is active. Flight director selection and Autopilot and yaw damper statuses are shown in the center of the AFCS Status Box. Lateral Flight Director modes are displayed on the left and vertical on the right. Armed modes are displayed in white and active in green.

AFCS status annunciations are displayed on the PFD above the Airspeed and Attitude indicators. Only one annunciation may occur at a time. Messages are prioritized by criticality.

Section 8 – Handling, Service, & Maintenance

No Change.

Section 10 – Safety Information

No Change.

Pilot's Operating Handbook and
FAA Approved Airplane Flight Manual Supplement
for the

Garmin Terrain Awareness/Warning System

(Aircraft Serials w/ Integrated Avionics Only)

When the Garmin Terrain Awareness/Warning System is installed on the aircraft, this POH Supplement is applicable and must be inserted in the Supplements Section of the Pilot's Operating Handbook. This document must be carried in the airplane at all times. Information in this supplement adds to, supersedes, or deletes information in the basic Pilot's Operating Handbook.

• Note •

This POH Supplement Change, dated Revision 01: 01-06-10, supersedes and replaces the Original release of this POH Supplement dated 05-13-08.

FAA Approved

Joseph C. Miss
for Charles Smalley, Manager

Jan 06 2010
Date

Chicago Aircraft Certification Office, ACE-115C
Federal Aviation Administration

Section 1 - General

The airplane is equipped with the Garmin Terrain Awareness/Warning System that performs the functions of a Class C Terrain Awareness and Warning System (TAWS) in accordance with TSO C151b.

Refer to the ATPI Integrated Flight Deck Pilot's Guide for a additional information on the system and its operating modes.

Section 2 - Limitations

1. Do not use Terrain Awareness and Warning System for navigation of the aircraft. The TAWS is intended to serve as a situational awareness tool only and may not provide the accuracy fidelity on which to solely base terrain or obstacle avoidance maneuvering decisions.
2. To avoid getting unwanted alerts, TAWS must be inhibited when landing at an airport that is not included in the airport database.

• Note •

Only vertical maneuvers are recommended responses to warnings and cautions unless operating in VMC or the pilot determines, using all available information and instruments, that a turn, in addition to the vertical escape maneuver, is the safest course of action. During certain operations, warning thresholds may be exceeded due to specific terrain or operating procedures. During day VFR flight, these warnings may be considered as cautionary.

Pilots are authorized to deviate from their current air traffic control (ATC) clearance to the extent necessary to comply with a TAWS warning.

Section 3 - Emergency Procedures

To prevent unwanted aural alerting during ditching or other off-airport landings, inhibit the Terrain Awareness System functions by selecting the INHIBIT Softkey on the TAWS Page.

Response To TAWS Warnings

Red PULL UP Warning

PULL UP

Aural "PULL UP" Warning

Aural "TERRAIN AHEAD" Warning

Aural "OBSTACLE AHEAD" Warning

1. Level the wings, simultaneously adding full power.
2. Increase pitch attitude to 15 degrees nose up.
3. Adjust pitch attitude to ensure terrain clearance while respecting stall warning. If flaps are extended, retract flaps to the UP position.
4. Continue climb at best angle of climb speed (V_x) until terrain clearance is assured.

Section 3A - Abnormal Procedures

Response To TAWS Cautions

Amber TERRAIN Caution

TERRAIN

Aural "TERRAIN AHEAD" Caution

Aural "OBSTACLE AHEAD" Caution

Aural "CAUTION, TERRAIN" Caution

Aural "SINK RATE" Caution

Aural "DON'T SINK" Caution

Aural "TOO LOW, TERRAIN" Caution

1. Take positive corrective action until the alert ceases. Stop descending, or initiate a climb turn as necessary, based on analysis of all available instruments and information.

Section 4 - Normal Procedures

Normal operating procedures are outlined in the ATPI Integrated Flight Deck Pilot's Guide.

Alert Priority

When any of the TAWS aural alerts are in progress, all aural TRAFFIC alerts are inhibited.

Advisory Callout

The advisory callout "*FIVE HUNDRED*", occurs at approximately 500 feet AGL.

Section 5 - Performance

No Change.

Section 6 - Weight & Balance

No Change.

Section 7 - System Description

The Terrain Awareness/Warning System receives data from the GPS receiver to determine horizontal position and altitude and compares this information to the onboard terrain and obstacle databases to calculate and "predict" the aircraft's flight path in relation to the surrounding terrain and obstacles. In this manner, TAWS provides advanced alerts of predicted dangerous terrain conditions via aural alerts communicated thru the pilot's headset and color-coded terrain annunciations displayed on the PFD.

Refer to the ATPI Integrated Flight Deck Pilot's Guide for a additional information on the system and its operating modes.

System Constraints

System test at startup: Aural tone lasting approximately one second indicates successful completion of internal system test.

Red TAWS FAIL Warning

TAWS FAIL

Aural “TAWS SYSTEM FAILURE” Warning

1. TAWS power-up self-test has failed or TAWS has detected problems with database validity, hardware status, and/or GPS status.

White TAWS N/A Advisory

TAWS N/A

Aural “TAWS NOT AVAILABLE” Advisory

Should the 3-D GPS navigation solution become degraded or if the aircraft is out of the database coverage area, the annunciation ‘TAWS N/A’ is generated in the annunciation window and on the TAWS Page. The aural message “TAWS NOT AVAILABLE” is generated. When the GPS signal is re-established and the aircraft is within the database coverage area, the aural message “TAWS AVAILABLE” is generated.

Geometric Altitude versus Measured Sea Level

TAWS uses information provided from the GPS receiver to provide a horizontal position and altitude. This data serves as the reference for color-coding for the TAWS Page and as an input to the TAWS Hazard Avoidance algorithms. Because it is derived from GPS, Geometric Altitude may differ from corrected barometric altitude. Therefore, Geometric Altitude may be in error by as much as 100 ft and should not be used for navigation.

Intentionally Left Blank

**Pilot's Operating Handbook and
FAA Approved Airplane Flight Manual
Supplement
for**

**S-Tec Fifty Five X Autopilot w/
Optional Flight Director**

(Aircraft Serials w/ Integrated Avionics Only)

When the System Fifty Five X Autopilot with Optional Flight Director System is installed on the aircraft, this POH Supplement is applicable and must be inserted in the Supplements Section of the basic Pilot's Operating Handbook. This document must be carried in the airplane at all times. Information in this supplement adds to, supersedes, or deletes information in the basic Pilot's Operating Handbook.

• Note •

This POH Supplement Change, dated Revision 01: 01-06-10, supersedes and replaces the Original release of this POH Supplement dated 12-18-08.

FAA Approved

Joseph C. Miss

Jan 06 2010
Date

for Charles Smalley, Manager
Chicago Aircraft Certification Office, ACE-115C
Federal Aviation Administration

Section 1 - General

This airplane is equipped with an S-TEC System Fifty Five X Autopilot and, if installed, an integrated Flight Director System.

Refer to S-Tec System Fifty Five X Pilot's Operating Handbook for full operational procedures and description of implemented modes.

Refer to the Integrated Avionics System Pilot's Guide for a detailed description of the avionics system and its operating modes.

Section 2 - Limitations

1. The appropriate revision of the S-Tec System Fifty Five X, Pilot's Operating Handbook for Integrated Equipped ATPI Aircraft, (p/n 87277) must be immediately available to the pilot during flight.
2. Autopilot operation is prohibited above 185 KIAS.
3. The autopilot must not be engaged for takeoff or landing.
4. The autopilot must be disengaged for missed approach, go-around, and bailed landing.
5. Flaps must be set to 50% for autopilot operation in Altitude Hold at airspeeds below 95 KIAS.
6. Flap deflection is limited to 50% during autopilot operations.
7. The autopilot must be disconnected in moderate or severe turbulence.
8. Minimum engage height for the autopilot is 400 ft AGL.
9. Minimum speed with the autopilot engaged is $1.2V_s$ for the given configuration.
10. For VOR/GPS and ILS glideslope and localizer intercept, capture, and tracking, the following limitations apply:
 - a. The autopilot must be disengaged no later than 100 feet below the Minimum Descent Altitude.
 - b. The autopilot must be disconnect during approach if course deviation exceeds 50%. The approach should only be continued by "hand-flying" the airplane.
 - c. The autopilot must be disengaged at the Decision Height.

- d. 12 knot maximum crosswind component between the missed approach point and outer marker.
- e. The intercept of the localizer shall occur at least 5 miles outside of the outer marker.
- f. If the crosswind component is greater than 12 knots and less than 17 knots, the intercept shall occur at least 10 miles outside of the outer marker.
- g. The intercept angle shall be no greater than a 45-degree intercept.
- h. The ILS is flown at normal approach speeds, and within any STC or TC speed constraints and as defined in this flight manual.
- i. The flaps should be extended in the approach configuration prior to the Outer Marker. No further changes in the flap configuration should be made throughout the autopilot-coupled approach.
- j. The glideslope is approached in such a manner to allow automatic arming of the glideslope, or if the glideslope is manually armed no more than 15% above the glideslope.

Section 3 - Emergency Procedures

Autopilot Malfunction

Refer to *Electric Trim/Autopilot Failure* procedure in the basic Pilot's Operating Handbook. Do not reengage the autopilot until the malfunction has been identified and corrected. The autopilot may be disconnected by:

1. Pressing the A/P DISC on the control yoke.

or

2. Pulling the KEYPADS/AP CTRL circuit breaker on MAIN BUS 1.

Altitude lost during a roll or pitch axis autopilot malfunction and recovery:

Flight Phase	Bank Angle	Altitude Loss
Climb	40°	200 ft
Cruise	45°	300 ft
Descent	40°	350 ft
Maneuvering	10°	60 ft
Approach	10°	80 ft

Section 3A - Abnormal Procedures

Autopilot Display Flashing Caution Annunciations

If any of the following failure annunciations occur at low altitude or during an actual instrument approach, disengage the autopilot, execute a go-around or missed approach as appropriate. Inform ATC of problem. Do not try to troubleshoot until a safe altitude and maneuvering area are reached or a safe landing is completed.

Flashing RDY for 5 seconds with audible tone.

RDY

Autopilot disconnect. All annunciations except RDY are cleared.

1. Continue flight without autopilot.

Flashing RDY with audible tone then goes out.

RDY

Turn coordinator gyro speed low. Autopilot disengages and cannot be re-engaged.

1. Check power to turn coordinator.

Continued on following page.

Flashing NAV, REV, or APR

NAV

or

REV

or

APR

Off navigation course by 50% needle deviation or more.

1. Use HDG mode until problem is identified. Crosscheck raw NAV data, compass heading, and radio operation.

Flashing NAV, REV, or APR with steady FAIL

NAV

or

REV

or

APR

and

FAIL

Invalid radio navigation signal.

1. Check Nav radio for proper reception. Use HDG mode until problem is corrected.

Flashing VS

VS

Excessive vertical speed error over selected vertical speed. Usually occurs in climb.

1. Reduce VS command and/or adjust power as appropriate.

Flashing GS**GS**

Off glideslope centerline by 50% needle deviation or more.

1. Check attitude and power. Adjust power as appropriate.

Flashing GS with steady FAIL.**GS***and***FAIL**

Invalid glideslope radio navigation signal.

1. Disconnect autopilot and initiate go-around or missed approach procedure. Inform ATC.

Flashing GS with steady ALT**GS***and***FAIL**

Manual glideslope disabled.

1. Re-enable by pressing NAV mode button.

Section 4 - Normal Procedures

• Note •

Additional normal operating procedures for the System Fifty Five X are described in the S-Tec System Fifty Five X Pilot's Operating Handbook.

Pre-Flight Inspection

1. Manual Electric Trim..... TEST
Press the AP DISC button down and hold while commanding trim.
Trim should not operate either nose up or nose down.
2. Engage Autopilot Heading ModePress HDG button
3. Engage Autopilot Altitude Hold ModePress ALT button
4. Autopilot OverrideTEST
Move flight controls fore, aft, left and right to verify that the autopilot can be overpowered.
5. Disengage Autopilot..... Press AP DISC button
6. Trim SET FOR TAKEOFF
7. Autopilot RDY Light CHECK ON
8. Trim airplane for existing flight conditions.

Mode Selection

Heading Mode

1. Set the PFD Heading Bug to the desired heading on the compass card.
2. Press HDG on Programmer/Computer. The HDG annunciation will illuminate and the airplane will turn to the selected heading.
3. Use the PFD Heading Bug to make heading changes as desired.

Navigation Mode

1. Select a reliable VOR or VOR-LOC signal on the NAV receiver.
2. Set the PFD Course Pointer to the desired course on the compass card.
3. Press NAV on Programmer/Computer. The HDG annunciation will illuminate and the airplane will turn to the selected navigational aid.

If the course needle is at full-scale deflection or if the aircraft's closure rate to the selected course is sufficiently slow, the autopilot will establish the airplane on a heading for a 45° intercept with the selected course. Otherwise, the intercept angle will be less than 45°. As the airplane approaches the course, the autopilot will smoothly shallow the intercept angle.

To manually select an intercept angle other than 45°:

- a. Set the PFD Heading Bug to the desired course, such that the difference between this heading and the desired course is the intercept angle.
- b. Set the PFD Course Pointer to the desired course.
- c. Press and hold HDG and simultaneously press NAV once on the Programmer/Computer. HDG and NAV annunciations will illuminate and the airplane will turn to the selected heading.
- d. When the on-course intercept turn begins the HDG mode will disengage and the annunciation will go out.

Global Positioning System Steering (GPSS) Mode

1. Select a reliable GPS signal on the NAV receiver.
2. Engage GPSS mode:
 - a. If NAV mode is already engaged, press NAV on Programmer/Computer once.
 - b. If NAV mode is not engaged, press NAV on Programmer/Computer twice.
3. The NAV annunciation and GPSS will illuminate and the autopilot will steer the aircraft along the predefined course programmed into the NAV receiver.

During the GPSS mode of operation, the autopilot will not accept any course error input from the PFD Course Pointer.

If there are no programmed course segments in the Programmer/Computer upon attempted engagement of the GPSS mode, the FAIL annunciation will appear, NAV and GPSS annunciations will flash, and the autopilot will hold the aircraft's wings level.

To manually select an intercept angle:

- a. Set the PFD Heading Bug to the desired course, such that the difference between this heading and the desired course is the intercept angle.
- b. Press and hold HDG and simultaneously press NAV twice on the Programmer/Computer. HDG, NAV, and GPSS annunciations will illuminate and the airplane will turn to the selected heading.
- c. When the on-course intercept turn begins the HDG mode will disengage and the annunciation will go out.

Altitude Hold Mode

1. Manually fly the airplane to the desired altitude and level off.
2. Press HDG, NAV, GPSS, APR, or REV to engage a roll mode. The associated annunciations will illuminate.
3. Press ALT on the Programmer/Computer. The ALT annunciation will illuminate indicating that the mode is engaged and the autopilot will hold the present altitude.

Manually flying the airplane off the selected altitude will not disengage altitude hold and the autopilot will command a pitch change to recapture the altitude when the control input is released.

Altitude can be changed to another altitude by rotating the VS knob on the Programmer/Computer.

Engagement of the altitude hold mode will reset the PFD Altitude Bug to the captured altitude.

Vertical Speed Mode

1. Press HDG, NAV, GPSS, APR, or REV to engage a roll mode. The associated annunciations will illuminate.
2. Set the PFD Vertical Speed Bug to the desired vertical speed.
3. Press VS on the Programmer/Computer to engage the vertical speed mode. The VS annunciation will illuminate indicating that the mode is engaged and the autopilot will synchronize to and hold the vertical speed at the time the mode was engaged.

The vertical speed is displayed in 100-foot increments at the far right of the Programmer/Computer window next to the VS annunciation. A plus (+) value indicates climb and a negative or minus (-) value indicates descent.

4. Vertical speed can be adjusted by rotating the VS knob on the Programmer/Computer.

Altitude Pre-Select Function

The altitude selector may be used to set up an altitude and vertical speed for intercept and capture. The altitude can be above or below the current altitude and the vertical speed chosen should be appropriate (climb or descent) for the altitude. Once selected, the altitude and vertical speed can be coupled to the autopilot by pressing and holding the VS button and then pressing the ALT button.

1. Press HDG, NAV, GPSS, APR, or REV to engage a roll mode. The associated annunciations will illuminate.
2. Set the PFD Altitude Bug to the desired altitude.
3. Press and hold VS and simultaneously press ALT to engage the vertical speed mode and arm the altitude hold mode.
4. ALT and VS annunciations will appear and the autopilot will attain and hold the aircraft at the vertical speed at the rate of climb/descent when engaged. Use the VS knob on the Programmer/Computer for vertical speed adjustment.

As the aircraft approaches the target altitude, a reduction in the vertical speed will automatically occur to ensure that there is no adverse acceleration at the point of capture. Once the target altitude has been captured, the VS annunciation will extinguish to indicate engagement of the altitude hold (ALT) mode.

Prior to altitude capture, with the VS mode engaged and the ALT mode armed, the PFD Vertical Speed Bug and/or PFD Altitude Bug can be changed at any time, causing the autopilot to respond accordingly.

During the pre-select sequence, with the VS mode engaged and the ALT mode armed, the following are subject to occur:

- Pressing the ALT mode selector switch once will disengage the VS mode, and engage the ALT mode. Consequently, the VS annunciation will extinguish, the PFD Vertical Speed Bug will disappear. This may cause some adverse acceleration, as the autopilot works to hold the aircraft at the captured altitude.
- Pressing the VS mode selector switch once will disarm the ALT mode, but leave the VS mode engaged. Consequently, the ALT annunciation will extinguish.

Flight Director Operation - AP MODE (Optional)

In AP MODE, the Flight Director provides a visual indication of how accurately the Autopilot is tracking the roll and pitch commands.

1. At Flight Director Remote Switches, press AP ON.
2. Press HDG, NAV, GPSS, APR, or REV to engage a roll mode. The associated annunciations will illuminate.
3. Press ALT, VS, or GS to engage a pitch mode. The associated annunciations will illuminate.

The Flight Director Command Bars turn solid magenta and the autopilot steers the aircraft toward the Command Bars until the Aircraft Reference Symbol is tucked into them.

Flight Director Operation - FD MODE (Optional)

In FD MODE, the Flight Director provides a visual indication of how accurately the Pilot is tracking the roll and pitch commands.

1. At Flight Director Remote Switches, press AP OFF / FD ON.
2. Press HDG, NAV, GPSS, APR, or REV to engage a roll mode. The associated annunciations will illuminate.
3. Press ALT, VS, or GS to engage a pitch mode. The associated annunciations will illuminate.

The Flight Director Command Bars are displayed hollow and the pilot steers the aircraft toward the Command Bars until the Aircraft Reference Symbol is tucked into them.

Section 5 - Performance**• WARNING •**

The autopilot may not be able to maintain all selectable vertical speeds. Selecting a vertical speed that exceeds the aircraft's available performance may cause the aircraft to stall.

The autopilot will disconnect if the Stall Warning System is activated.

Section 6 - Weight & Balance

Refer to Section 6 - Weight and Balance of the basic POH for current weight and balance data.

Section 7 - System Description

The airplane is equipped with an S-Tec System Fifty Five X two-axis autopilot and, if installed, an integrated Flight Director System. The system consists of the Programmer / Computer, Flight Management System Keyboard, Turn Coordinator, Altitude Transducer, Integrated Avionics Unit #2, Pitch Servo, Roll and Pitch Trim Cartridges, Autopilot Disconnect Switch, Electric Pitch-Trim and Roll-Trim Hat Switch, Optional Flight Director Switches, and Annunciation System.

The autopilot controls the aircraft pitch, and roll attitudes while following commands received from the optional Flight Director. Autopilot operation occurs within the Programmer/Computer installed in the upper section of the center console and provides:

- Autopilot engagement and annunciation
- Autopilot command and control
- Auto-trim operation
- Manual electric trim
- Two axis airplane control (pitch and roll), including approaches

The optional Flight Director provides pitch and roll commands to the autopilot system and displays them on the PFD. With the Flight Director activated, the pilot can hand-fly the aircraft to follow the path shown by the Command Bars. Flight Director operation takes place within the #2 Integrated Avionics Unit and provides:

- Mode annunciation
- Vertical reference control
- Pitch and roll command calculation
- Pitch and roll command display

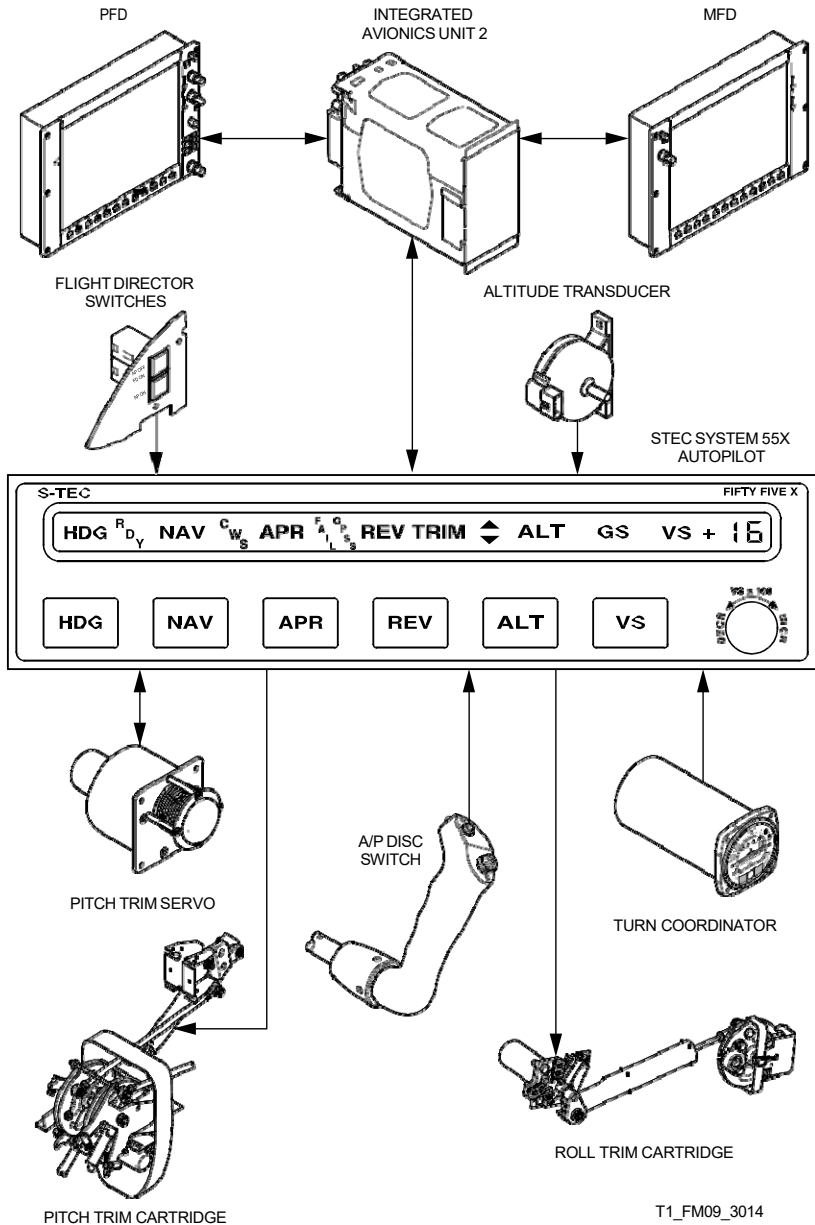

T1_FM09_3014

Figure - 1
System Schematic

Programmer / Computer

The Programmer / Computer, located in the upper section of the center console, provides primary control of autopilot modes.

28 VDC for Programmer / Computer operation is supplied through the 5-amp KEYPADS / AP CTRL circuit breaker on MAIN BUS 1.

All Autopilot mode selection is performed by using the mode select buttons and VS modifier knob. Available functions are as follows:

RDY - Ready Mode

Illuminates when autopilot is ready for engagement. When the airplane's Battery Master switch is turned on and the rate gyro RPM is correct, the RDY annunciation will come on indicating the autopilot is ready for the functional check and operation. The autopilot cannot be engaged unless the RDY light is illuminated.

HDG - Heading Button

When pressed, will engage the Heading mode, which commands the airplane to turn to and maintain the heading selected by the heading bug on the HSI. A new heading may be selected at any time and will result in the airplane turning to the new heading.

NAV - Navigation Button

When NAV is selected, the autopilot will provide intercept and tracking of GPS, VOR, and Localizer courses. For course intercept with full-scale deflection, the autopilot automatically sets up a 45° intercept angle at maximum gain and sensitivity. The point at which the turn to capture the course begins is dependent upon closure rate and airplane position. When the course is intercepted and the HSI course deviation needle centered, the autopilot automatically initiates a tracking gain program to reduce turn rate to 45% standard rate, and then 15% standard rate.

GPSS - GPS Steering Mode

Pressing NAV twice will cause the autopilot to go to GPSS for smoother tracking and transitions. When GPSS is selected, the autopilot can be switched between heading and GPSS modes of operation. In the heading mode, the converter receives a heading error signal from the heading bug on the Horizontal Situation Indicator.

GPSS converts this information and sends this heading error directly to the autopilot.

In the GPSS mode the autopilot can be directly coupled to the roll Commands produced by the GPS Navigator, eliminating the need for the pilot to make any further adjustments to the HSI course arrow.

ALT - Altitude Hold Button

When ALT is selected, the autopilot will hold the altitude at the time the mode was selected. Altitude hold will not engage if an autopilot roll mode is not engaged. Altitude correction for enroute barometric pressure changes may be made by rotation of the VS knob on the Programmer/Computer.

VS - Vertical Speed Button

When VS is selected, the autopilot will synchronize to and hold the vertical speed at the time the mode was selected. Altitude hold will not engage if an autopilot roll mode is not engaged. The vertical speed is displayed in 100-foot increments at the far right of the Programmer/Computer window next to the VS annunciation. A plus (+) value indicates climb and a negative or minus (-) value indicates descent. Vertical speed can be adjusted by rotating the VS knob on the Programmer/Computer.

APR - Approach Button

When APR is selected, the autopilot provides increased sensitivity for VOR or GPS approaches. APR may also be used to provide increased sensitivity for enroute course tracking

GS - Glideslope Mode

The autopilot GS function will capture and track an ILS glideslope. To arm the GS function, the following conditions must be met:

1. The NAV receiver must be tuned to the appropriate ILS frequency.
2. The glideslope signal must be valid – no flag.
3. The autopilot must be in NAV/APR/ALT modes.
4. The airplane must be 60% or more below the glideslope centerline during the approach to the intercept point, and within 50% needle deviation of the localizer centerline at the point of intercept – usually the outer marker.

When the above conditions have existed for 10 seconds, the GS annunciation will illuminate indicating GS arming has occurred (ALT annunciation will remain on). When the glideslope is intercepted and captured, the ALT annunciation will go out.

REV- Reverse Course Button

When REV is selected, the autopilot will automatically execute high sensitivity gain for an approach where tracking the front course outbound or tracking the back course inbound is required. The APR and REV annunciations will illuminate when REV is selected.

TRIM – Auto-trim Mode

When both a roll mode and a pitch mode are engaged, the autopilot will provide an annunciation whenever it is automatically trimming the aircraft. Should the pitch servo loading exceed a preset threshold for a period of three seconds, the autopilot will annunciate either TRIM ▲ or TRIM ▼ as an advisement that the autopilot is automatically trimming the aircraft. If the autopilot is still in the process of automatically trimming the aircraft after four more seconds, the annunciation will flash. When the aircraft has been sufficiently trimmed, the annunciation will extinguish.

VS Modifier Knob

The VS Knob on the Programmer/Computer is used to change the vertical speed when in vertical speed mode and controls altitude reference when in altitude hold mode. Each 'click' of the knob results in a step increase or decrease in the selected mode by the amount shown in the table below.

Mode	Step Value	Range
Altitude Hold (ALT)	20 Feet	+/- 360 Feet*
Vertical speed (VS)	100 Feet per Minute	+/- 1600 Feet per Minute

* Adjustments greater than 360 feet can be made by selecting VS mode and flying the airplane to the new altitude and then re-engaging ALT mode

Flight Management System Keyboard

The Flight Management System Keyboard, found in the center console above the programmer / computer, is the primary means for data entry for the MFD and is used to control NAV/COM Radios, transponder, and flight management system entry. Heading, course and altitude select are also provided.

28 VDC for Flight Management System Keyboard operation is supplied through 5-amp KEYPADS / AP CTRL circuit breaker on MAIN BUS 1.

HDG - Heading Knob.

The HDG knob controls the selected heading bug on the HSI portion of the PFD. It provides the reference for heading select mode. Pushing the HDG knob synchronizes the selected heading to the current heading.

CRS - Course Knob

The CRS knob controls the course pointer on the HSI portion of the PFD. It provides the reference for FD navigation modes when the Flight Director is selected. Pushing the CRS knob re-centers the CDI and returns the course pointer to the bearing of the active waypoint or navigation station.

ALT SEL - Altitude Select Knob

The ALT knob controls the Selected Altitude, which is used as the reference for the altitude alerter and the altitude capture function. Pushing the ALT SEL knob synchronizes the selected altitude to the displayed altitude to the nearest 10 ft.

Turn Coordinator

The electric turn coordinator, installed behind the RH bolster panel, provides roll data to the Programmer/Computer. Roll rate is sensed by a single-gimbal, electric-powered gyro.

28 VDC for Turn Coordinator operation is supplied through the 5-amp KEYPADS / AP CTRL circuit breaker on MAIN BUS 1.

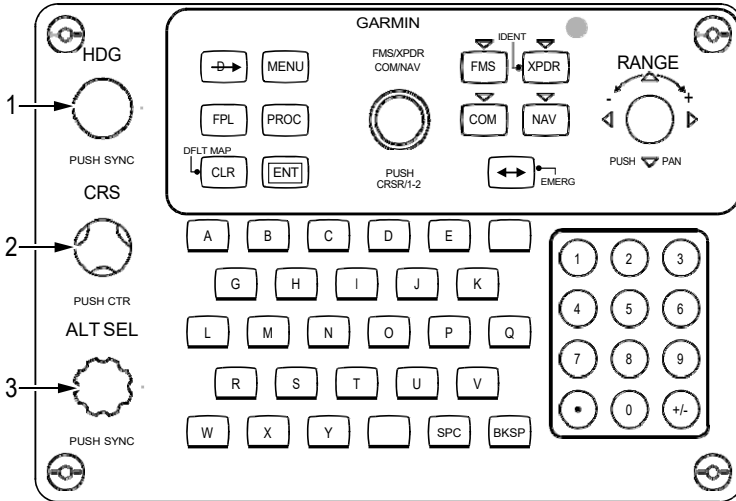

Flight Management System Keyboard

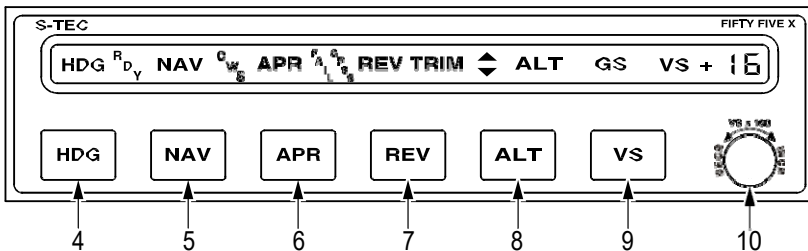

System 55X Autopilot

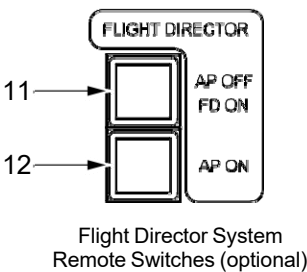

Flight Director System
Remote Switches (optional)

Legend

1. Heading Selection
2. Course Selection
3. Altitude Selection
4. Heading Select Mode
5. Navigation Mode
6. Approach Mode
7. Reverse Course Mode
8. Altitude Hold
9. Vertical Speed Mode
10. VS Modifier Knob
11. Flight Director Mode
12. Autopilot Mode

T1_FM09_3016

Figure - 2
System Fifty Five X Autopilot w/ Optional Flight Director

Altitude Transducer

The altitude transducer, installed behind the bolster panel and plumbing directly into the Pitot Static system provides altitude information to the Programmer/Computer.

#2 Integrated Avionics Units

The #2 Integrated Avionics Unit located behind the MFD and instrument panel, functions as the main communication hub to the Avionics System and Programmer / Computer, linking the systems to the PFD and MFD displays. The Integrated Avionics Unit receives air and attitude data parameters from the Air Data Computer and Attitude and Heading Reference System. The Integrated Avionics Unit contains a GPS WAAS receiver, VHF COM/NAV/GS receivers, and system integration microprocessors.

28 VDC for #2 Integrated Avionics Unit operation is supplied through the 7.5-amp COM 2 and 5-amp GPS NAV GIA2 circuit breakers on the MAIN BUS 2.

Pitch Servo

The Pitch Servo, located below the baggage compartment position the aircraft flight controls in response to commands generated by the Programmer/Computer autopilot calculations.

28 VDC for Pitch Servo operation is supplied through the 5-amp KEYPADS/AP CTRL circuit breaker on MAIN BUS 1.

Roll and Pitch Trim Cartridges

Roll and pitch trim is provided by adjusting the neutral position of the compression spring cartridge in the elevator control system by means of an electric motor. For detailed description of the Trim Cartridges refer to the basic POH.

Electric Pitch/Roll-Trim Hat Switch

The yoke mounted Electric Pitch Trim and Roll Trim Hat Switch allows the pilot to manually adjust aircraft trim when the autopilot is not engaged. For detailed description of the Electric Pitch/Roll-Trim Hat Switch refer to the basic POH.

Autopilot Disconnect Switch

The yoke mounted Autopilot Disconnect Switch disengages the autopilot and may also be used to mute the aural alert associated with an AP disconnect.

Flight Director System (Optional)

The Flight Director system enhances situational awareness by reducing cockpit workload through providing a visual cue for the pilot to follow as indicated by the PFD's Flight Director Command Bars. Through turning or pitching the airplane as "directed" by the Command Bars, the pilot will follow the necessary course to arrive at a programmed destination.

The system consists of Flight Director Remote Switches installed on the upper, LH side of the instrument panel and associated relays and wiring between the PFD and autopilot. The remaining portion of the Flight Director system is entirely software dependent. The Flight Director Remote Switches control system activation and mode. The switches are automatically dimmed for ambient light conditions by a phototransistor located on the top of the glare-shield.

• Note •

Covering the phototransistor in daylight may result in unreadable flight director status indication.

The following describes Remote Switch annunciation, color, and related Autopilot and Flight Director status:

- No Annunciation - Autopilot OFF or Autopilot not active in pitch control.
- Green AP ON - Autopilot active in roll and pitch control. If Autopilot active in roll and pitch control, AP annunciation appears on top edge of PFD, and Flight Director Command Bars solid magenta.
- Amber AP OFF / FD ON - Autopilot uncoupled. If Autopilot active in roll and pitch control, Flight Director ON and Flight Director Command Bars displayed hollow magenta.

The Flight Director system is powered by 28 VDC through the 5-amp AUTOPILOT circuit breaker on the Essential Bus.

Annunciation System

• Note •

Refer to the ATPI Integrated Pilot's Guide for a detailed description of the annunciator system and all warnings, cautions and advisories.

Autopilot Status Box and Mode Annunciation

In addition to the Failure and Caution Annunciations displayed on the Programmer / Computer, Autopilot selection and status annunciations are displayed on the PFD above the Airspeed and Attitude indicators.

If installed, Flight Director mode annunciations are displayed on the PFD when the Flight Director is active. Flight Director selection and status is shown in the center of the Autopilot Status Box. Lateral Flight Director modes are displayed on the left and vertical on the right. Armed modes are displayed in white and active in green.

Section 8 – Handling, Service, & Maintenance

No Change.

Section 10 – Safety Information

No Change.

Intentionally Left Blank

**Pilot's Operating Handbook and
FAA Approved Airplane Flight Manual
Supplement
for**

S-Tec Fifty Five SR Autopilot

(Aircraft Serials w/ Integrated Avionics Only)

When the System Fifty Five SR Autopilot is installed on the aircraft, this POH Supplement is applicable and must be inserted in the Supplements Section of the basic Pilot's Operating Handbook. This document must be carried in the airplane at all times. Information in this supplement adds to, supersedes, or deletes information in the basic Pilot's Operating Handbook.

• Note •

This POH Supplement Change, dated Revision 01: 01-06-10, supersedes and replaces the Original release of this POH Supplement dated 12-18-08.

FAA Approved

Joseph C. Miss

Date Jan 06 2010

for Charles Smalley, Manager
Chicago Aircraft Certification Office, ACE-115C
Federal Aviation Administration

Section 1 - General

This airplane is equipped with an S-TEC System Fifty Five SR Autopilot. Refer to S-Tec System Fifty Five SR Pilot's Operating Handbook for full operational procedures and description of implemented modes.

Refer to the Integrated Avionics System Pilot's Guide for a detailed description of the avionics system and its operating modes

Section 2 - Limitations

1. The appropriate revision of the S-Tec System Fifty Five X, Pilot's Operating Handbook for Integrated Equipped ATPI Aircraft, (p/n 87277) must be immediately available to the pilot during flight.
2. Autopilot operation is prohibited above 185 KIAS.
3. The autopilot must not be engaged for takeoff or landing.
4. The autopilot must be disengaged for missed approach, go-around, and balked landing.
5. Flaps must be set to 50% for autopilot operation in Altitude Hold at airspeeds below 95 KIAS.
6. Flap deflection is limited to 50% during autopilot operations.
7. The autopilot must be disconnected in moderate or severe turbulence.
8. Minimum engage height for the autopilot is 400 ft AGL.
9. Minimum speed with the autopilot engaged is $1.2V_S$ for the given configuration.
10. For VOR/GPS and ILS glideslope and localizer intercept, capture, and tracking, the following limitations apply:
 - a. The autopilot must be disengaged no later than 100 feet below the Minimum Descent Altitude.
 - b. The autopilot must be disconnect during approach if course deviation exceeds 50%. The approach should only be continued by "hand-flying" the airplane.
 - c. The autopilot must be disengaged at the Decision Height.

- d. 12 knot maximum crosswind component between the missed approach point and outer marker.
- e. The intercept of the localizer shall occur at least 5 miles outside of the outer marker.
- f. If the crosswind component is greater than 12 knots and less than 17 knots, the intercept shall occur at least 10 miles outside of the outer marker.
- g. The intercept angle shall be no greater than a 45-degree intercept.
- h. The flaps should be extended in the approach configuration prior to the Outer Marker. No further changes in the flap configuration should be made throughout the autopilot-coupled approach.

Section 3 - Emergency Procedures

Autopilot Malfunction

Refer to *Electric Trim/Autopilot Failure* procedure in the basic Pilot's Operating Handbook. Do not reengage the autopilot until the malfunction has been identified and corrected. The autopilot may be disconnected by:

1. Pressing the A/P DISC on the control yoke.

or

2. Pulling the KEYPADS/AP CTRL circuit breaker on MAIN BUS 1.

Altitude lost during a roll or pitch axis autopilot malfunction and recovery:

Flight Phase	Bank Angle	Altitude Loss
Climb	40°	200 ft
Cruise	45°	300 ft
Descent	40°	350 ft
Maneuvering	10°	60 ft
Approach	10°	80 ft

Section 3A - Abnormal Procedures

Autopilot Display Flashing Caution Annunciations

If any of the following failure annunciations occur at low altitude or during an actual instrument approach, disengage the autopilot, execute a go-around or missed approach as appropriate. Inform ATC of problem. Do not try to troubleshoot until a safe altitude and maneuvering area are reached or a safe landing is completed.

Flashing RDY for 5 seconds with audible tone.

RDY

Autopilot disconnect. All annunciations except RDY are cleared.

1. Continue flight without autopilot.

Flashing RDY with audible tone then goes out.

RDY

Turn coordinator gyro speed low. Autopilot disengages and cannot be re-engaged.

1. Check power to turn coordinator.

Continued on following page.

Flashing NAV, REV, or APR

NAV

or

REV

or

APR

Off navigation course by 50% needle deviation or more.

1. Use HDG mode until problem is identified. Crosscheck raw NAV data, compass heading, and radio operation.

Continued on following page.

Flashing NAV, REV, or APR with steady FAIL

NAV

or

REV

or

APR

and

FAIL

Invalid radio navigation signal.

1. Check Nav radio for proper reception. Use HDG mode until problem is corrected.

Flashing VS

VS

Excessive vertical speed error over selected vertical speed. Usually occurs in climb.

1. Reduce VS command and/or adjust power as appropriate.

Section 4 - Normal Procedures

• Note •

Additional normal operating procedures for the System Fifty Five SR are described in the S-Tec System Fifty Five SR Pilot's Operating Handbook.

Pre-Flight Inspection

1. Manual Electric Trim TEST
Press the AP DISC button down and hold while commanding trim. Trim should not operate either nose up or nose down.
2. Engage Autopilot Heading Mode Press HDG button
3. Engage Autopilot Altitude Hold Mode Press ALT button
4. Autopilot Override TEST
Move flight controls fore, aft, left and right to verify that the autopilot can be overpowered.
5. Disengage Autopilot Press AP DISC button
6. Trim SET FOR TAKEOFF
7. Autopilot RDY Light CHECK ON
8. Trim airplane for existing flight conditions.

Mode Selection

Heading Mode

1. Set the PFD Heading Bug to the desired heading on the compass card.
2. Press HDG on Programmer/Computer. The HDG annunciation will illuminate and the airplane will turn to the selected heading.
3. Use the PFD Heading Bug to make heading changes as desired.

Navigation Mode

1. Select a reliable VOR or VOR-LOC signal on the NAV receiver.
2. Set the PFD Course Pointer to the desired course on the compass card.
3. Press NAV on Programmer/Computer. The HDG annunciation will illuminate and the airplane will turn to the selected navigational aid.

If the course needle is at full-scale deflection or if the aircraft's closure rate to the selected course is sufficiently slow, the autopilot will establish the airplane on a heading for a 45° intercept with the selected course. Otherwise, the intercept angle will be less than 45°. As the airplane approaches the course, the autopilot will smoothly shallow the intercept angle.

To manually select an intercept angle other than 45°:

- a. Set the PFD Heading Bug to the desired course, such that the difference between this heading and the desired course is the intercept angle.
- b. Set the PFD Course Pointer to the desired course.
- c. Press and hold HDG and simultaneously press NAV once on the Programmer/Computer. HDG and NAV annunciations will illuminate and the airplane will turn to the selected heading.
- d. When the on-course intercept turn begins the HDG mode will disengage and the annunciation will go out.

Global Positioning System Steering (GPSS) Mode

1. Select a reliable GPS signal on the NAV receiver.
2. Engage GPSS mode:
 - a. If NAV mode is already engaged, press NAV on Programmer/Computer once.
 - b. If NAV mode is not engaged, press NAV on Programmer/Computer twice.
3. The NAV annunciation and GPSS will illuminate and the autopilot will steer the aircraft along the predefined course programmed into the NAV receiver.

During the GPSS mode of operation, the autopilot will not accept any course error input from the PFD Course Pointer.

If there are no programmed course segments in the Programmer/Computer upon attempted engagement of the GPSS mode, the FAIL annunciation will appear, NAV and GPSS annunciations will flash, and the autopilot will hold the aircraft's wings level.

To manually select an intercept angle:

- a. Set the PFD Heading Bug to the desired course, such that the difference between this heading and the desired course is the intercept angle.
- b. Press and hold HDG and simultaneously press NAV twice on the Programmer/Computer. HDG, NAV, and GPSS annunciations will illuminate and the airplane will turn to the selected heading.
- c. When the on-course intercept turn begins the HDG mode will disengage and the annunciation will go out.

Altitude Hold Mode

1. Manually fly the airplane to the desired altitude and level off.
2. Press HDG, NAV, GPSS, APR, or REV to engage a roll mode. The associated annunciations will illuminate.
3. Press ALT on the Programmer/Computer. The ALT annunciation will illuminate indicating that the mode is engaged and the autopilot will hold the present altitude.

Manually flying the airplane off the selected altitude will not disengage altitude hold and the autopilot will command a pitch change to recapture the altitude when the control input is released.

Altitude can be changed to another altitude by rotating the VS knob on the Programmer/Computer.

Engagement of the altitude hold mode will reset the PFD Altitude Bug to the captured altitude.

Vertical Speed Mode

1. Press HDG, NAV, GPSS, APR, or REV to engage a roll mode. The associated annunciations will illuminate.
2. Set the PFD Vertical Speed Bug to the desired vertical speed.
3. Press VS on the Programmer/Computer to engage the vertical speed mode. The VS annunciation will illuminate indicating that the mode is engaged and the autopilot will synchronize to and hold the vertical speed at the time the mode was engaged.

The vertical speed is displayed in 100-foot increments at the far right of the Programmer/Computer window next to the VS annunciation. A plus (+) value indicates climb and a negative or minus (-) value indicates descent.

4. Vertical speed can be adjusted by rotating the VS knob on the Programmer/Computer.

Section 5 - Performance

• WARNING •

The autopilot may not be able to maintain all selectable vertical speeds. Selecting a vertical speed that exceeds the aircraft's available performance may cause the aircraft to stall.

The autopilot will disconnect if the Stall Warning System is activated.

Section 6 - Weight & Balance

Refer to Section 6 - Weight and Balance of the basic POH for current weight and balance data.

Section 7 - System Description

The airplane is equipped with an S-Tec System Fifty Five SR two-axis autopilot. The system consists of the Programmer / Computer, Flight Management System Keyboard, Turn Coordinator, Altitude Transducer, Integrated Avionics Unit #2, Pitch Servo, Roll and Pitch Trim Cartridges, Autopilot Disconnect Switch, Electric Pitch-Trim and Roll-Trim Hat Switch, and Annunciation System.

The autopilot controls the aircraft pitch and roll attitudes. Autopilot operation occurs within the Programmer/Computer installed in the upper section of the center console and provides:

- Autopilot engagement and annunciation
- Autopilot command and control
- Auto-trim operation
- Manual electric trim
- Two axis airplane control (pitch and roll), including approaches

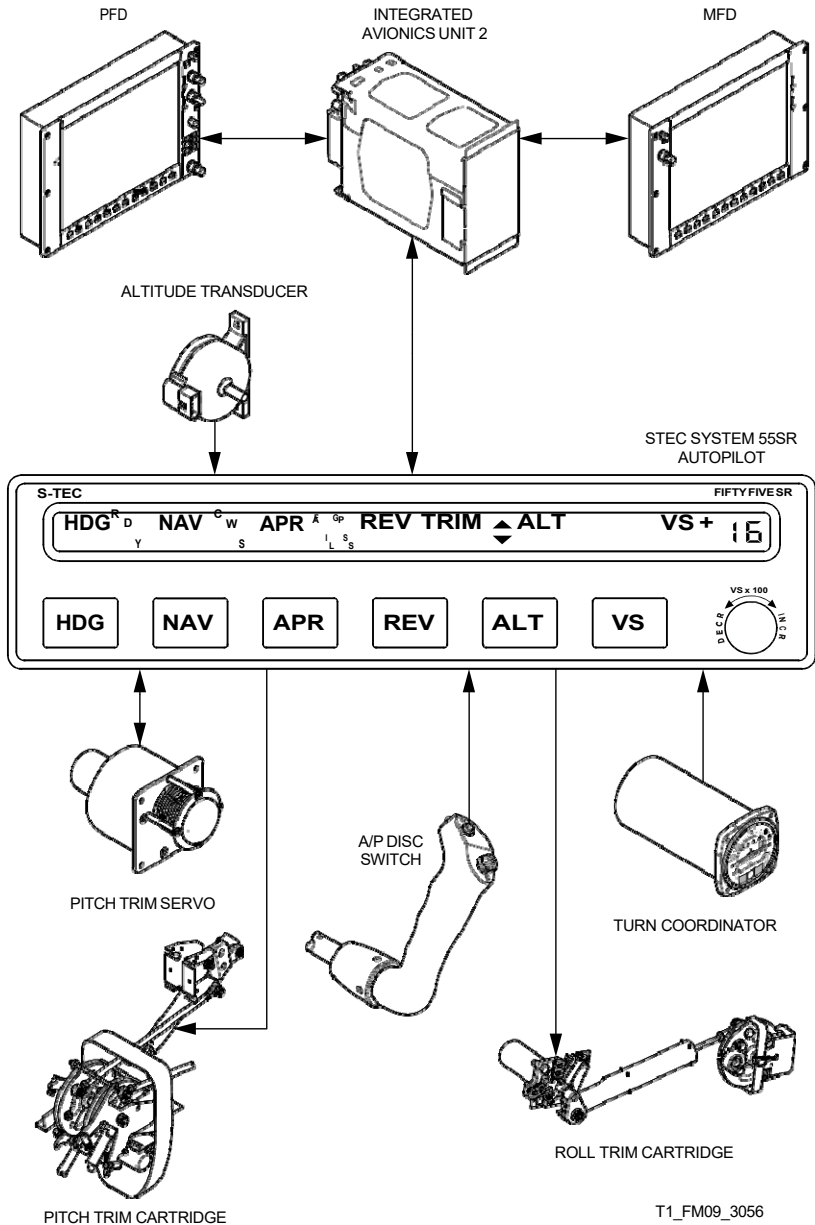

Figure - 1
System Schematic

Programmer / Computer

The Programmer / Computer, located in the upper section of the center console, provides primary control of autopilot modes.

28 VDC for Programmer / Computer operation is supplied through the 5-amp KEYPADS / AP CTRL circuit breaker on MAIN BUS 1.

All Autopilot mode selection is performed by using the mode select buttons and VS modifier knob. Available functions are as follows:

RDY - Ready Mode

Illuminates when autopilot is ready for engagement. When the airplane's Battery Master switch is turned on and the rate gyro RPM is correct, the RDY annunciation will come on indicating the autopilot is ready for the functional check and operation. The autopilot cannot be engaged unless the RDY light is illuminated.

HDG - Heading Button

When pressed, will engage the Heading mode, which commands the airplane to turn to and maintain the heading selected by the heading bug on the HSI. A new heading may be selected at any time and will result in the airplane turning to the new heading.

NAV - Navigation Button

When NAV is selected, the autopilot will provide intercept and tracking of GPS, VOR, and Localizer courses. For course intercept with full-scale deflection, the autopilot automatically sets up a 45° intercept angle at maximum gain and sensitivity. The point at which the turn to capture the course begins is dependent upon closure rate and airplane position. When the course is intercepted and the HSI course deviation needle centered, the autopilot automatically initiates a tracking gain program to reduce turn rate to 45% standard rate, and then 15% standard rate.

GPSS - GPS Steering Mode

Pressing NAV twice will cause the autopilot to go to GPSS for smoother tracking and transitions. When GPSS is selected, the autopilot can be switched between heading and GPSS modes of operation. In the heading mode, the converter receives a heading error signal from the heading bug on the Horizontal Situation Indicator.

GPSS converts this information and sends this heading error directly to the autopilot.

In the GPSS mode the autopilot can be directly coupled to the roll Commands produced by the GPS Navigator, eliminating the need for the pilot to make any further adjustments to the HSI course arrow.

ALT - Altitude Hold Button

When ALT is selected, the autopilot will hold the altitude at the time the mode was selected. Altitude hold will not engage if an autopilot roll mode is not engaged. Altitude correction for enroute barometric pressure changes may be made by rotation of the VS knob on the Programmer/Computer.

VS - Vertical Speed Button

When VS is selected, the autopilot will synchronize to and hold the vertical speed at the time the mode was selected. Altitude hold will not engage if an autopilot roll mode is not engaged. The vertical speed is displayed in 100-foot increments at the far right of the Programmer/Computer window next to the VS annunciation. A plus (+) value indicates climb and a negative or minus (-) value indicates descent. Vertical speed can be adjusted by rotating the VS knob on the Programmer/Computer.

APR - Approach Button

When APR is selected, the autopilot provides increased sensitivity for VOR or GPS approaches. APR may also be used to provide increased sensitivity for enroute course tracking

REV- Reverse Course Button

When REV is selected, the autopilot will automatically execute high sensitivity gain for an approach where tracking the front course outbound or tracking the back course inbound is required. The APR and REV annunciations will illuminate when REV is selected.

TRIM - Autotrim Mode

When both a roll mode and a pitch mode are engaged, the autopilot will provide an annunciation whenever it is automatically trimming the aircraft. Should the pitch servo loading exceed a preset threshold for a period of three seconds, the autopilot will annunciate either TRIM ▲ or TRIM ▼ as an advisement that the autopilot is automatically trimming

the aircraft. If the autopilot is still in the process of automatically trimming the aircraft after four more seconds, the annunciation will flash. When the aircraft has been sufficiently trimmed, the annunciation will extinguish.

VS Modifier Knob

The VS Knob on the Programmer/Computer is used to change the vertical speed when in vertical speed mode and controls altitude reference when in altitude hold mode. Each 'click' of the knob results in a step increase or decrease in the selected mode by the amount shown in the table below.

Mode	Step Value	Range
Altitude Hold (ALT)	20 Feet	+/- 360 Feet*
Vertical speed (VS)	100 Feet per Minute	+/- 1600 Feet per Minute

* Adjustments greater than 360 feet can be made by selecting VS mode and flying the airplane to the new altitude and then re-engaging ALT mode

Flight Management System Keyboard

The Flight Management System Keyboard, found in the center console above the programmer / computer, is the primary means for data entry for the MFD and is used to control NAV/COM Radios, transponder, and flight management system entry. Heading, course and altitude select are also provided.

28 VDC for Flight Management System Keyboard operation is supplied through 5-amp KEYPADS / AP CTRL circuit breaker on MAIN BUS 1.

HDG - Heading Knob.

The HDG knob controls the selected heading bug on the HSI portion of the PFD. It provides the reference for heading select mode. Pushing the HDG knob synchronizes the selected heading to the current heading.

CRS - Course Knob

The CRS knob controls the course pointer on the HSI portion of the PFD. Pushing the CRS knob re-centers the CDI and returns the course pointer to the bearing of the active waypoint or navigation station.

ALT SEL - Altitude Select Knob

The ALT knob controls the Selected Altitude, which is used as the reference for the altitude alerter and the altitude capture function. Pushing the ALT SEL knob synchronizes the selected altitude to the displayed altitude to the nearest 10 ft.

Turn Coordinator

The electric turn coordinator, installed behind the RH bolster panel, provides roll data to the Programmer/Computer. Roll rate is sensed by a single-gimbal, electric-powered gyro.

28 VDC for Turn Coordinator operation is supplied through the 5-amp KEYPADS / AP CTRL circuit breaker on MAIN BUS 1.

Altitude Transducer

The altitude transducer, installed behind the bolster panel and plumbing directly into the Pitot Static system provides altitude information to the Programmer/Computer.

#2 Integrated Avionics Units

The #2 Integrated Avionics Unit located behind the MFD and instrument panel, functions as the main communication hub to the Avionics System and Programmer / Computer, linking the systems to the PFD and MFD displays. The Integrated Avionics Unit receives air and attitude data parameters from the Air Data Computer and Attitude and Heading Reference System. The Integrated Avionics Unit contains a GPS WAAS receiver, VHF COM/NAV/GS receivers, and system integration microprocessors.

28 VDC for #2 Integrated Avionics Unit operation is supplied through the 7.5-amp COM 2 and 5-amp GPS NAV GIA2 circuit breakers on the MAIN BUS 2.

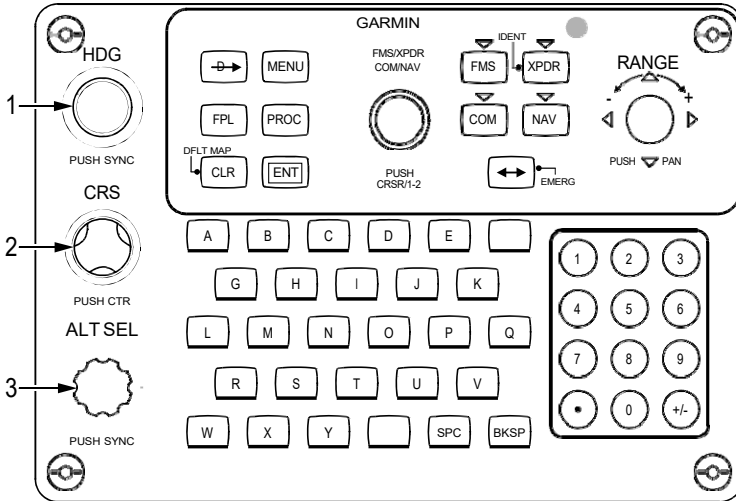

Flight Management System Keyboard

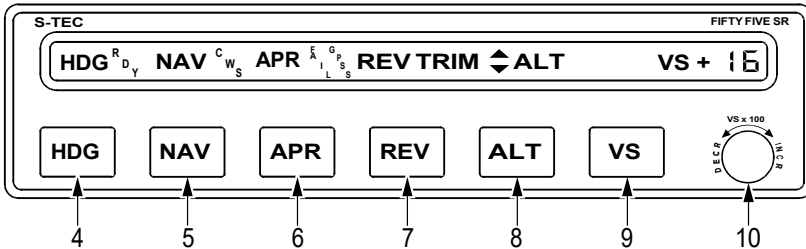

System 55SR Autopilot

Legend

1. Heading Selection
2. Course Selection
3. Altitude Selection
4. Heading Select Mode
5. Navigation Mode
6. Approach Mode
7. Reverse Course Mode
8. Altitude Hold
9. Vertical Speed Mode
10. VS Modifier Knob

T1_FM09_3057

Figure - 2
System Fifty Five SR Autopilot

Pitch Servo

The Pitch Servo, located below the baggage compartment position the aircraft flight controls in response to commands generated by the Programmer/Computer autopilot calculations.

28 VDC for Pitch Servo operation is supplied through the 5-amp KEYPADS/AP CTRL circuit breaker on MAIN BUS 1.

Roll and Pitch Trim Cartridges

Roll and pitch trim is provided by adjusting the neutral position of the compression spring cartridge in the elevator control system by means of an electric motor. For detailed description of the Trim Cartridges refer to the basic POH.

Electric Pitch/Roll-Trim Hat Switch

The yoke mounted Electric Pitch Trim and Roll Trim Hat Switch allows the pilot to manually adjust aircraft trim when the autopilot is not engaged. For detailed description of the Electric Pitch/Roll-Trim Hat Switch refer to the basic POH.

Autopilot Disconnect Switch

The yoke mounted Autopilot Disconnect Switch disengages the autopilot and may also be used to mute the aural alert associated with an AP disconnect.

Annunciation System

• Note •

Refer to the ATPI Integrated Pilot's Guide for a detailed description of the annunciator system and all warnings, cautions and advisories.

Autopilot Status Box and Mode Annunciation

In addition to the Failure and Caution Annunciations displayed on the Programmer / Computer, Autopilot selection and status annunciations are displayed on the PFD above the Airspeed and Attitude indicators.

Section 8 – Handling, Service, & Maintenance

No Change.

Section 10 – Safety Information

No Change.

**Pilot's Operating Handbook and
FAA Approved Airplane Flight Manual
Supplement
for**

**14 Code of Federal Regulations (CFR) Part 135
Commercial Operation of Small Aircraft
Electrical Loading Shedding Procedure**

This supplement provides the necessary guidance for load shed in the event of a primary electrical generating source failure in accordance with 14 CFR Section 135.163(f).

When the aircraft is being operated under the provisions 14 CFR 135, this Supplement is applicable and must be inserted in the Supplements Section of the Pilot's Operating Handbook. Information in this Supplement adds to, supersedes, or deletes information in the basic handbook.

• Note •

This POH Supplement Change, dated Revision 02: 01-06-10, supersedes and replaces the Revision 01 release of this POH Supplement dated 03-26-09.

FAA Approved Joseph C. Miss Date Jan 06 2010
for Charles Smalley, Manager
Chicago Aircraft Certification Office, ACE-115C
Federal Aviation Administration

Section 1 - General

No Change.

Section 2 - Limitations

Kinds of Operation Equipment List

Aircraft Serial Numbers 22-0002 thru 22-3416 before SB2X-33-03 Rev 1 or later, LED Position/Strobe Assembly Installation:

System, Instrument, and/or Equipment	Kinds of Operation			
	VFR Day	VFR Nt.	IFR Day	IFR Nt.
Lights				
LED Position/Strobe Assembly	1	1	1	1

Section 3 - Emergency Procedures

Aircraft Serials with Avidyne PFD/MFD Avionics

ALT 1 Failure (Alt 1 Light Steady)

Steady illumination indicates failure of alternator 1. Attempt to restore alternator. If alternator cannot be restored, it will be necessary to divert the flight to land within one hour.

Loads on Main Buses, Non-essential Buses, and Air-conditioning Buses must be reduced and available equipment on these buses managed as necessary for flight conditions. Equipment essential for continued safe flight and landing will be powered by Alternator 2 and Battery 2 through the Essential Buses. However, depending upon flight conditions, additional equipment is required.

For 14 CFR 135 Operations, the load shedding and equipment management in the following procedure will provide at least one-hour operating time on aircraft with a fully charged, 13.6 amp-hour battery (available from ATPI Design Spare Parts Sales) in good condition for equipment required for emergency operation under 14 CFR 135.163(f) and meets the requirements of that paragraph.

• Note •

Circuit breakers that "PULL" should only be pulled and not reset.

1. ALT 1 Master Switch OFF
2. Alternator 1 Circuit Breaker Check and Reset
3. ALT 1 Master Switch ON
If alternator does not reset
4. ALT 1 Master Switch OFF
5. Notify ATC of Alternator Failure and that transponder may be switched off depending upon flight conditions.
6. Autopilot ENGAGE
Use of autopilot will reduce work load and provide trim function. Expect a slight pitch change when autopilot is disengaged.
7. NAV Lights ON

Continued on following page.

- 8. Reduce loads as required for flight conditions:
 - a. Air Conditioning and FanOFF
 - b. Convenience OutletDisconnect appliance
 - c. Audio PanelOFF
COM 1 will be supplied to pilot's headset. Communication with passengers through audio panel will not be available.
 - d. GPS/COM 2.....OFF
 - e. Fuel PumpOFF
except for landing and switching tanks.
 - f. Panel and Overhead LightsOFF
 - g. Landing Light.....OFF

• WARNING •

Do not shed loads from Avionics Essential, Essential, or Essential 2 Bus row.

- h. Skywatch/TAWS Circuit Breaker.....PULL
 - i. Weather/Stmscpe Circuit BreakerPULL
 - j. MFD Circuit BreakerPULL
- 9. Assess flight conditions:

If in Visual Meteorological Conditions (VMC):

- a. Pitot Heat.....OFF
- b. Ice Protection.....OFF

If in Instrument Meteorological Conditions (IMC) or visible moisture:

- a. Pitot Heat..... ON
- b. Ice Protection.....ON, As Reqd
- c. Strobe LightsOFF

- 10. Re-plan flight for a landing as soon as practical (within one hour) at a landing field with visual minimums. Increase landing speed 10 KIAS for flaps up. Do not use landing lights.

Aircraft Serials with Integrated PFD/MFD Avionics**ALT 1 Failure (Alt 1 Light Steady)**

Steady illumination indicates failure of alternator 1. Attempt to restore alternator. If alternator cannot be restored, Alternator 2, and Bat 2 will provide sufficient electrical power to supply all requirements for emergency operation of equipment indefinitely as is required by 14 CFR 135.163(f).

1. ALT 1 Master SwitchOFF
2. Alternator 1 Circuit BreakerCheck and Reset
3. ALT 1 Master SwitchON
If alternator does not reset
4. ALT 1 Master SwitchOFF
5. Notify ATC of Alternator Failure
6. Autopilot.....ENGAGE
Use of autopilot will reduce work load. Expect a slight pitch change when autopilot is disengaged.
7. Air Conditioning and FanOFF
8. Convenience OutletDisconnect appliance

Section 3A - Abnormal Procedures

No Change.

Section 4 - Normal Procedures

No Change.

Section 5 - Performance Data

No Change.

Section 6 – Weight and Balance

No Change.

Section 7 – Airplane and Systems Description

No Change.

Section 8 – Handling, Service, & Maintenance

No Change.

Section 9 – Supplements

No Change.

Section 10 – Safety Information

No Change.

Section 10

Safety Information

Table of Contents

Introduction	3
ATPI Airframe Parachute System (APS)	4
Deployment Scenarios	4
General Deployment Information	6
Landing Considerations.....	7
Taxiing, Steering, and Braking Practices	10
Operating Practices	10
Brake Maintenance.....	11

Intentionally Left Blank

Introduction

This aircraft is designed to operate safely and efficiently in a flight environment. However, like any other aircraft, pilots must maintain proficiency to achieve maximum safety, utility, and economy.

As the pilot you must be thoroughly familiar with the contents of this Handbook, the Handbook Supplements, Flight Checklist, and operational guides and data provided by manufacturers of equipment installed in this airplane. You must operate the airplane in accordance with the applicable FAA operating rules and within the Limitations specified in Section 2 of this Handbook.

The Normal Procedures section of this handbook was designed to provide guidance for day-to-day operation of this airplane. The procedures given are the result of flight testing, FAA certification requirements, and input from pilots with a variety of operational experience. Become fully familiar with the procedures, perform all the required checks, and operate the airplane within the limitations and as outlined in the procedures.

ATPI Airframe Parachute System (APS)

The ATPI Airframe Parachute System (APS) is designed to lower the aircraft and its passengers to the ground in the event of a life-threatening emergency. However, because APS deployment is expected to result in damage to the airframe and, depending upon adverse external factors such as high deployment speed, low altitude, rough terrain or high wind conditions, may result in severe injury or death to the aircraft occupants, its use should not be taken lightly. Instead, possible APS activation scenarios should be well thought out and mentally practiced by every pilot.

The following discussion is meant to guide your thinking about APS activation. It is intended to be informative, not directive. It is the responsibility of you, the pilot, to determine when and how the APS will be used.

Deployment Scenarios

This section describes possible scenarios in which the activation of the APS might be appropriate. This list is not intended to be exclusive, but merely illustrative of the type of circumstances when APS deployment could be the only means of saving the occupants of the aircraft.

Mid-Air Collision

A mid-air collision may render the airplane un-flyable by damaging the control system or primary structure. If a mid-air collision occurs, immediately determine if the airplane is controllable and structurally capable of continued safe flight and landing. If it is not, APS activation should be considered.

Structural Failure

Structural failure may result from many situations, such as: encountering severe gusts at speeds above the airplane's structural cruising speed, inadvertent full control movements above the airplane's maneuvering speed, or exceeding the design load factor while maneuvering. If a structural failure occurs, immediately determine if the airplane is controllable and structurally capable of continued safe flight and landing. If it is not, APS activation should be considered.

Loss of Control

Loss of control may result from many situations, such as: a control system failure (disconnected or jammed controls); severe wake turbulence, severe turbulence causing upset, severe airframe icing, or sustained pilot disorientation caused by vertigo or panic; or a spiral/spin. If loss of control occurs, determine if the airplane can be recovered. If control cannot be regained, the APS should be activated. This decision should be made prior to your pre-determined decision altitude (2,000' AGL, as discussed below).

Landing Required in Terrain not Permitting a Safe Landing

If a forced landing is required because of engine failure, fuel exhaustion, excessive structural icing, or any other condition APS activation is only warranted if a landing cannot be made that ensures little or no risk to the aircraft occupants. However, if the condition occurs over terrain thought not to permit such a landing, such as: over extremely rough or mountainous terrain, over water out of gliding distance to land, over widespread ground fog or at night, APS activation should be considered.

Pilot Incapacitation

Pilot incapacitation may be the result of anything from a pilot's medical condition to a bird strike that injures the pilot. If this occurs and the passengers cannot reasonably accomplish a safe landing, APS activation by the passengers should be considered. This possibility should be explained to the passengers prior to the flight and all appropriate passengers should be briefed on APS operation so they could effectively deploy APS if required.

General Deployment Information

Deployment Speed

The maximum speed at which deployment has been demonstrated is 133 KIAS. Deployment at higher speeds could subject the parachute and aircraft to excessive loads that could result in structural failure. Once a decision has been made to deploy the APS, make all reasonable efforts to slow to the minimum possible airspeed. However, if time and altitude are critical, and/or ground impact is imminent, the APS should be activated regardless of airspeed.

Deployment Altitude

No minimum altitude for deployment has been set. This is because the actual altitude loss during a particular deployment depends upon the airplane's airspeed, altitude and attitude at deployment as well as other environmental factors. In all cases, however, the chances of a successful deployment increase with altitude. As a guideline, the demonstrated altitude loss from entry into a one-turn spin until under a stabilized parachute is 920 feet. Altitude loss from level flight deployments has been demonstrated at less than 400 feet. With these numbers in mind it might be useful to keep 2,000 feet AGL in mind as a cut-off decision altitude. Above 2,000 feet, there would normally be time to systematically assess and address the aircraft emergency. Below 2,000 feet, the decision to activate the APS has to come almost immediately in order to maximize the possibility of successful deployment. At any altitude, once the APS is determined to be the only alternative available for saving the aircraft occupants, deploy the system without delay.

Deployment Attitude

The APS has been tested in all flap configurations at speeds ranging from V_{SO} to V_A . Most APS testing was accomplished from a level attitude. Deployment from a spin was also tested. From these tests it was found that as long as the parachute was introduced to the free air by the rocket, it would successfully recover the aircraft into its level descent attitude under parachute. However, it can be assumed that to minimize the chances of parachute entanglement and reduce aircraft oscillations under the parachute, the APS should be activated from a wings-level, upright attitude if at all possible.

Landing Considerations

After a APS deployment, the airplane will descend at less than 1700 feet per minute with a lateral speed equal to the velocity of the surface wind. The APS landing touchdown is equivalent to ground impact from a height of approximately 13 feet. While the airframe, seats, and landing gear are designed to accommodate the stress, occupants must be prepared for the landing. The overriding consideration in all APS deployed landings is to prepare the occupants for the touchdown in order to protect them from injury as much as possible.

Emergency Landing Body Position

The most important consideration for a touchdown with APS deployed is to protect the occupants from injury, especially back injury. Contacting the ground with the back offset attempting to open a door or secure items increases the likelihood of back injury. All occupants must be in the emergency landing body position well before touchdown. After touchdown, all occupants should maintain the emergency landing body position until the airplane comes to a complete stop.

The emergency landing body position is assumed with tightened seat belt and shoulder harness by placing both hands on the lap, clasping one wrist with the opposite hand, and holding the upper torso erect and against the seat backs. The seat cushions contain an aluminum honeycomb core designed to crush under impact to absorb downward loads and help protect the spine from compression injury.

Door Position

For most situations, it is best to leave the doors latched and use the time available to transmit emergency calls, shut down systems, and get into the Emergency Landing Body Position well before impact. The discussion below gives some specific recommendations, however, the pilot's decision will depend upon all factors, including time to impact, altitude, terrain, winds, condition of airplane, etc.

There is the possibility that one or both doors could jam at impact. If this occurs, to exit the airplane, the occupants will have to force open a partially jammed door or break through a door window using the Emergency Exit Hammer located in the lid of the center armrest. This can significantly delay the occupants from exiting the airplane.

If the pilot elects to touchdown with a door opened, there are several additional factors the pilot must consider: loss of door, possibility of head injury, or injury from an object coming through the open door.

- If a door is open prior to touchdown in a APS landing, the door will most likely break away from the airplane at impact.
- If the door is open and the airplane contacts the ground in a rolled condition, an occupant could be thrown forward and strike their head on the exposed door pillar. Contacting the ground in a rolled condition could be caused by terrain that is not level, contacting an obstacle such as a tree, or by transient aircraft attitude.
- With a door open, it is possible for an object such as a tree limb or flying debris to come through the opening and strike an occupant.

• **WARNING** •

If it is decided to unlatch a door, unlatch one door only. Opening only one door will provide for emergency egress as well as reduce risks associated with ground contact. Typically, this would be the copilot's door as this allows the other occupants to exit first after the airplane comes to rest.

APS Landing Scenario	Door Position
Empty Copilot Seat	Unlatch Copilot Door
Very Little Time Before Impact	Keep Doors Closed
Fire	Unlatch Copilot Door
Water Landing	Unlatch Copilot Door
Condition Unknown	Keep Doors Closed

Water Landings

The ability of the airplane to float after a water landing has not been tested and is unknown. However, since there is the possibility that one or both doors could jam and use of the emergency egress hammer to break out a window could take some time, the pilot may wish to consider unlatching a door prior to assuming the emergency landing body position in order to provide a ready escape path should the airplane begin to sink.

Post Impact Fire

If there is no fire prior to touchdown and the pilot is able to shut down the engine, fuel, and electrical systems, there is less chance of a post impact fire. If the pilot suspects a fire could result from impact, unlatching a door immediately prior to assuming the emergency landing body position should be considered to assure rapid egress.

Ground Gusts

If it is known or suspected that ground gusts are present in the landing zone, there is a possibility that the parachute could drag the airplane after touchdown, especially if the terrain is flat and without obstacles. In order to assure that the occupants can escape the airplane in the timeliest manner after the airplane comes to rest, the pilot may elect to unlatch the copilot's door for the APS landing. Occupants must be in the Emergency Landing Body Position for touchdown. Occupants must not loosen seat belts until the airplane comes to rest. When the airplane comes to rest, the occupants should exit the airplane and immediately move upwind to prevent a sudden gust from dragging the airplane in their direction.

Taxiing, Steering, and Braking Practices

ATPI aircraft use a castering nose wheel and rely on aerodynamic forces and differential braking for directional control while taxiing. Proper braking practices are therefore critical to avoid potential damage to the brakes.

The most common cause of brake damage and/or failure is the creation of excessive heat through improper braking practices. Pilots unaccustomed to free castering nose wheel steering may be inclined to “ride” the brakes to maintain constant taxi speeds and use the brakes excessively for steering.

• Caution •

When brake temperatures are between 270-293°F (132-145°C), the Crew Alerting System will display a BRAKE TEMP Caution annunciation. A BRAKE TEMP Warning annunciation occurs when brake temperature exceeds 293°F (145°C). If either annunciation occurs, the pilot should stop the aircraft and allow the brakes to cool to avoid damaging the brake system.

Operating Practices

When taxiing, directional control is accomplished with rudder deflection and intermittent braking (toe taps) as necessary. Use only as much power as is necessary to achieve forward movement. Deceleration or taxi speed control using brakes but without a reduction in power will result in increased brake temperature.

On flat, smooth, hard surfaces, do not exceed 1000 RPM maximum continuous engine speed for taxi. Power settings slightly above 1000 RPM are permissible to start motion, for turf, soft surfaces, and on inclines. Use minimum power to maintain constant taxi speed.

“Riding the brakes” while taxiing is similar to driving a car with one foot on the brake and one foot on the gas. This causes a continuous build up of energy that would otherwise be moving the airplane.

Observe the following operating practices:

- Verify that the parking brake is completely disengaged before taxi.
- The rudder is effective for steering on the ground and should be used.

- Use only as much power (throttle) as is necessary to achieve forward movement. Keep in mind, any additional power added with the throttle will be absorbed in the brakes to maintain constant speed.
- Use rudder deflection and the minimum necessary inputs of differential braking to achieve directional control.
- Do not “ride the brakes”. Pilots should consciously remove pressure from the brakes while taxiing. Failure to do so results in excessive heat buildup, premature brake wear, and increased possibility of brake failure or fire.
- Avoid unnecessary high-speed taxiing. High-speed taxiing may result in excessive demands on the brakes, increased brake wear, and the possibility of brake failure or fire.
- Brakes have a large energy absorbing capacity; therefore, cooling time should be considered. Energy absorbed during a few seconds of deceleration can take up to an hour to dissipate. Always allow adequate cooling time after brake use.
- Allow a cooling period following a high-energy braking event. High-energy braking can include an aborted takeoff or the equivalent energy required for a Maximum Gross Weight full-stop from 70 knots in less than 1000 feet.

Brake Maintenance

The brake assemblies and linings should be checked at every oil change (50 hours) for general condition, evidence of overheating, and deterioration. *Serials 0002 thru 3450 before SB 2X-05-01*: At every annual/100-hour inspection the brakes should be disassembled, the brake linings should be checked and the O-rings must be replaced. Refer to Section 8, Handling, Servicing, and Maintenance for specific servicing information on the Brake System.

Intentionally Left Blank